

## Recall Campaign 8026C – Battery Label Concern

**Updated June 11, 2026. REMINDER: There are 3 photos required for this campaign. Also, do not proceed with any repair unless you have 2 stickers received from the vendor.**

Table of Contents - Links in this document are provided for all steps below

Flowchart, Tools and Parts.....Section A

Repair Procedure .....Section B

Campaign Label Installation .....Section C

### Vehicle Inspection Procedure and Preparation for Repair

1. Verify that the vehicle is within the following ranges and there is an OPEN 8026C campaign in eMDCS:

#### **Subject Vehicles:**

Model	Plant	Subject VIN range	Production date range
2025 CX-50 (Hybrid)	MTM	7MMVA****TN142667–145555	From September 8, 2025 to September 25, 2025

**\*\*Only VIN's in this range and with an "Open" status in eMDCS are included.**

2. If the vehicle does not have an OPEN or Announced 8026C campaign, return the vehicle to the customer or inventory.

3. Perform an eMDCS Warranty Vehicle Inquiry and inspect the vehicle for a Campaign Label with 8026C attached to the vehicle's hood, driver door or firewall.

**NOTE: Always be sure to verify the campaign number as the vehicle may have multiple campaign labels on the hood, radiator support, and firewall or driver door jamb.**

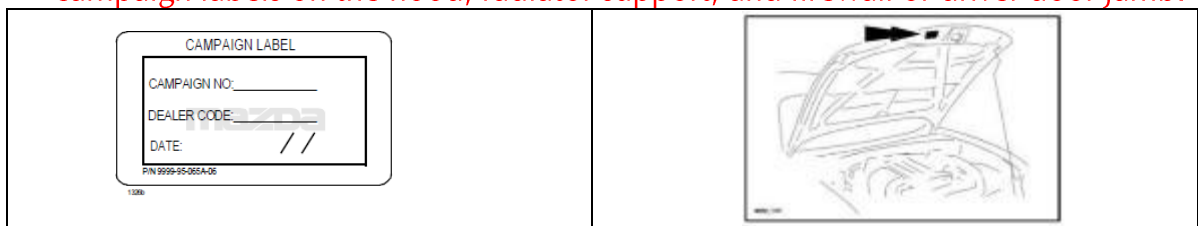

eMDCS - Warranty Vehicle Inquiry Results

If eMDCS displays:	Campaign Label is:	Action to perform:
If no repair date is displayed on the line with CAMPAIGN 8026C, the campaign has not been completed on this vehicle	Present	Fill out Dealer Recall Help on OneMazda contact or the Mazda Warranty Department at <a href="mailto:warrantydept@mazdausa.com">warrantydept@mazdausa.com</a> to review vehicle history.
	Not present	Proceed to "REPAIR PROCEDURE".
If repair date is displayed for CAMPAIGN 8026C, is "CLOSED"	Present	Return vehicle to inventory or customer.
	Not present	Complete a label and apply to vehicle's hood with repair date and dealer code from eMDCS Warranty Inquiry.
CAMPAIGN 8026C is not displayed	See Action	<b>The vehicle is not affected by the Recall</b>

**TECHNICIAN LEVEL REQUIRED: CERTIFIED OR ABOVE (DOES NOT MUST BE HYBRID CERTIFIED).**  
**Note: The technician repairing needs to be Certified or above and does not need to be Senior or Master as long as they have had the required training for the repair being conducted.**

**Section A : Flow Chart**

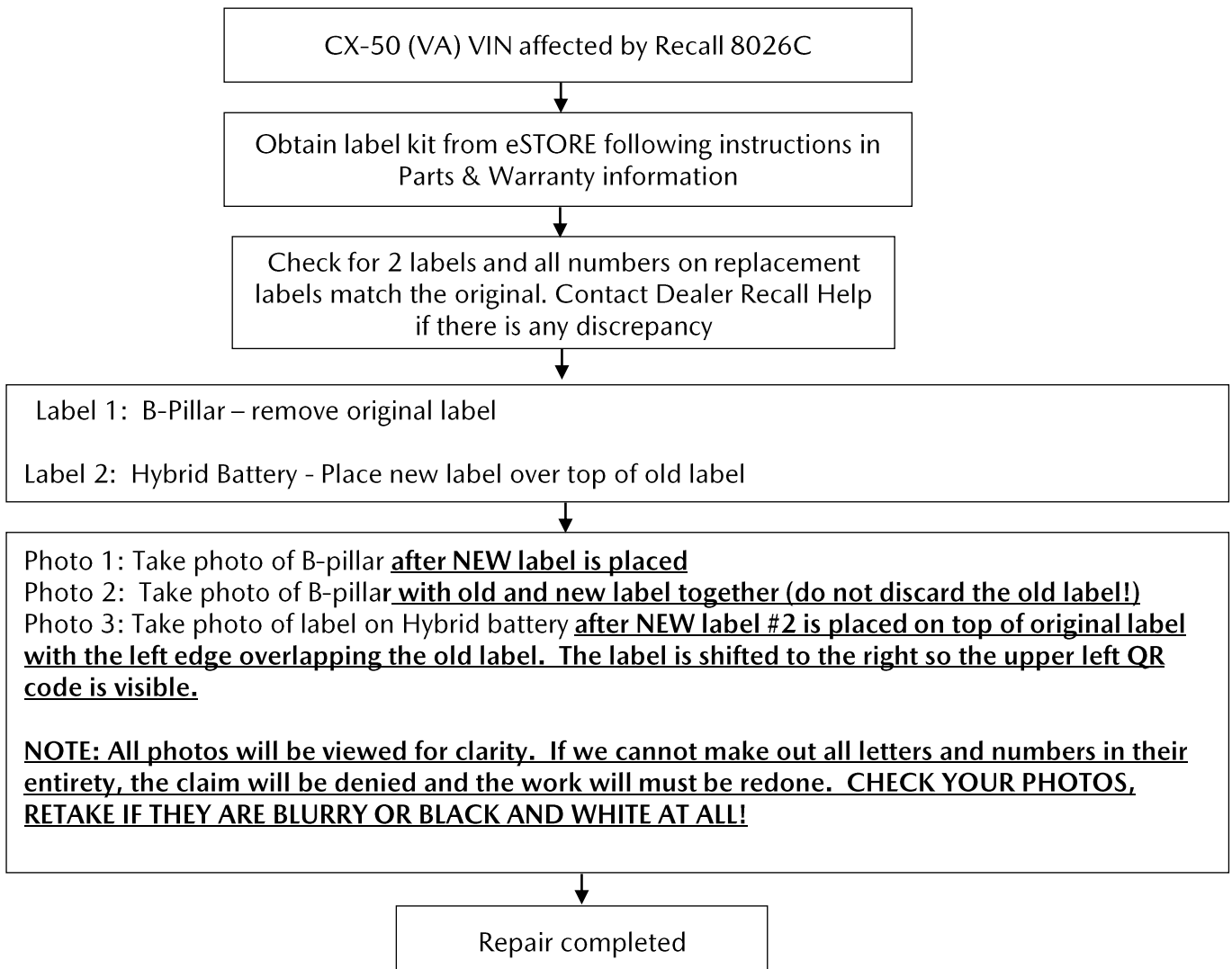



**Customer Personal Items:** If personal belongings need to be removed from vehicle interior or trunk area, please remember to neatly replace any customer items in the same location after the repair is completed. If items need to be removed, please kindly ask the customer to remove prior to beginning work on the vehicle.

Paint or other damage to interior or exterior: Care should be taken, and protective cover(s) used when working on any Mazda vehicle. Damage to any components, interior trim, vehicle accessories, body panels and paint will not be reimbursed by Mazda (including OEM or aftermarket). All of these items above could delay repairs, compromise safety, as well as negatively affect the customer experience and Mazda dealer-customer relationship.

**Tools Required:** No metal tools are to be used to remove the B-Pillar label.

(1)	Small, flat, plastic or non-metal scraper or spatula (shop supply)
(2)	Isopropol Alcohol or label remover chemical (shop supply)
(3)	Clean shop cloth or microfiber towel (shop supply)

### Parts Information

Description	Part Number	Quantity	Note
Label Kit (2 identical labels) ONE: B-Pillar, TWO: Hybrid Battery	NONE	1	Obtain in Mazda eStore
Campaign Completion Label	9999-95-065A-06	1 order=50 labels	Obtain in Mazda eStore

Package contents your Parts team will receive from eSTORE



**CHECK FOR TWO (2) LABELS  
WILL BE IN THIS BAG, SEE  
PHOTO NEXT PAGE**



There will be two (2) identical labels in the plastic bag. They may be stuck together.  
**DO NOT PROCEED WITH REPAIR UNLESS THERE ARE TWO LABELS.**

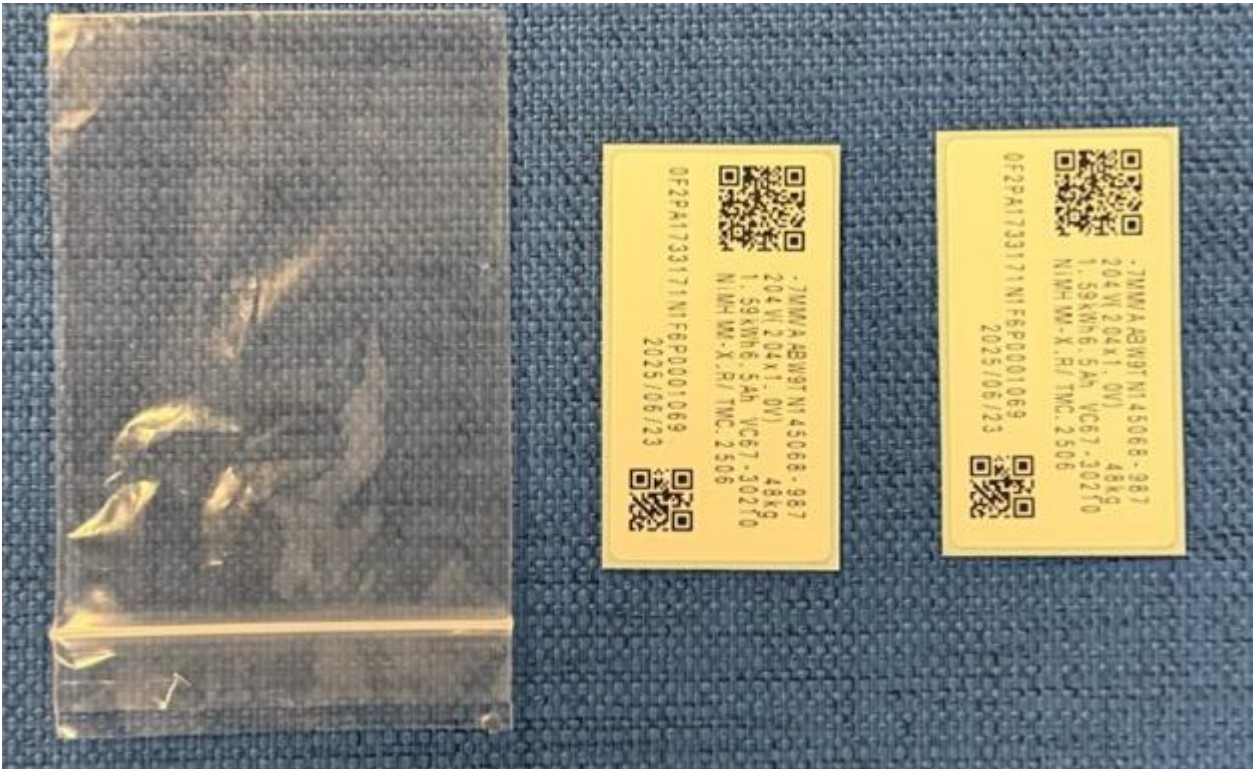

-----END OF SECTION A-----

## B. Repair Procedure

BEFORE REPAIRING – ORDER PARTS FROM ESTORE. FOLLOW STEPS IN THE WARRANTY INFORMATION TO ORDER FROM “CAMPAIGNS” in ESTORE. PLEASE DOUBLE CHECK THAT THE VIN MATCHES BEFORE LEAVING YOUR PARTS COUNTER.

LOST OR DAMAGED LABEL: IF YOU MISPLACED OR DAMAGED A LABEL, FILL OUT DEALER SPECIAL SERVICE PROGRAM HELP ON ONEMAZDA WITH A PHOTO OF THE DAMAGE AND REASON. IF MISSING EXPLAIN REASON WHY LABEL WAS LOST.

1. Verify that the VIN stamped on the floor matches the VIN on new correct two Battery labels.

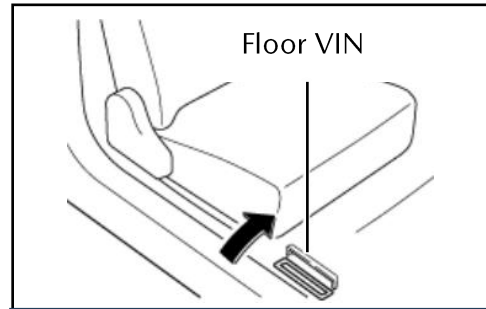

2. Verify that alphanumeric characters (1) to (8) on original battery label attached to B-pillar are same as those on new correct two battery label. No check is needed for the QR code. If any information from boxes 1 through 8 does not match the new labels you received, contact Dealer Recall Help

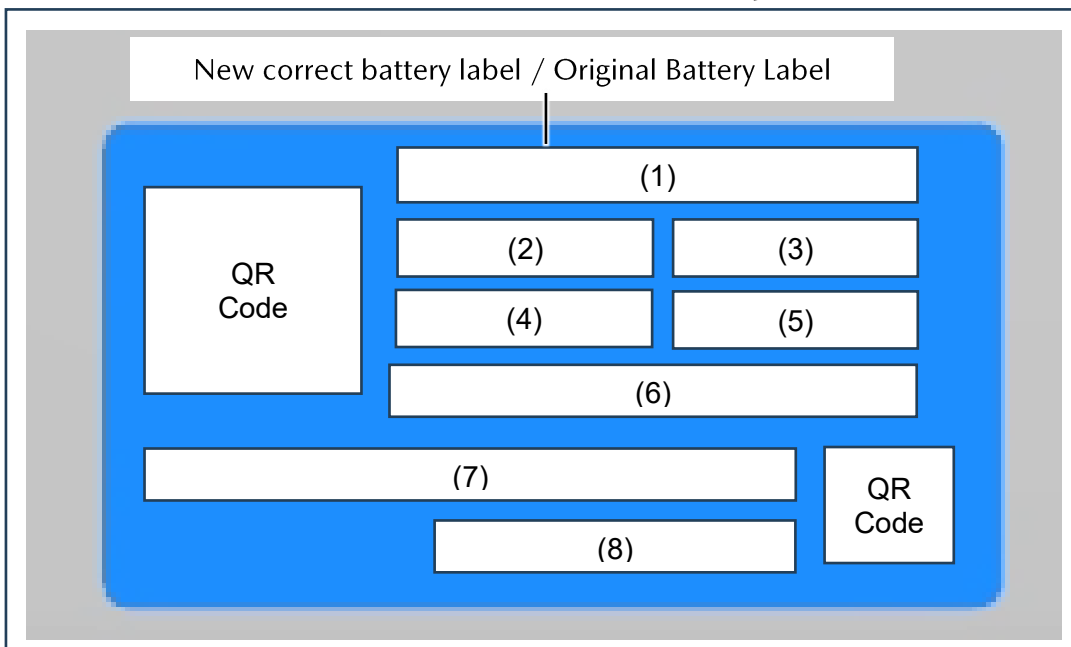
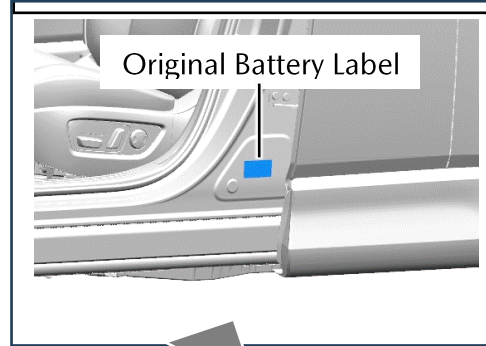

(1)	VIN
(2)	MINIMUM VOLTAGE
(3)	BATTERY PACK WEIGHT
(4)	BATTERY PACK CAPACITY

(5)	BATTERY PACK PART NUMBER
(6)	CHEMISTRY IDENTIFITER
(7)	BATTERY ID
(8)	DATE OF BATTERY MANUFACTURE

[ B-Pillar Battery Label placement SECTION ]

1. Remove Battery Label attached to the following location.

**NOTE:** Before removing Battery Label, clean and degrease body surface to prevent scratches using a clean shop cloth or microfiber cloth. \*Cleaning area is in light blue:

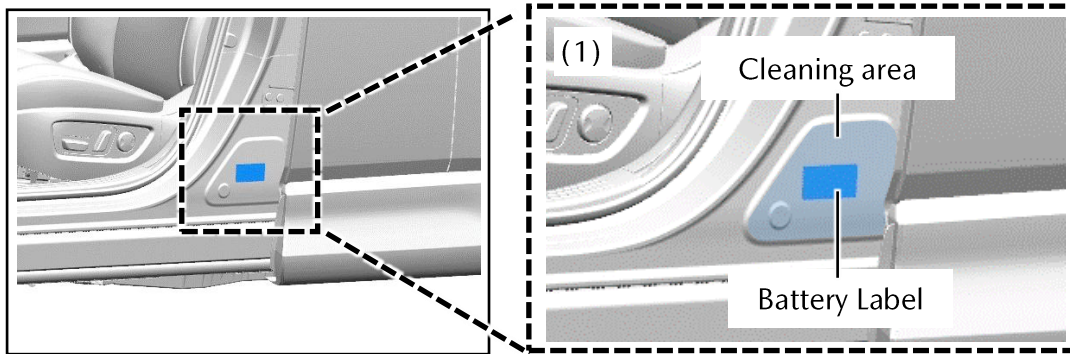

- a. Check the battery label (affected VIN) attached to the vehicle.

- b. Peel off Battery Label (**DO NOT DISCARD THE OLD LABEL, IT WILL BE REQUIRED IN A PHOTO**)

- 1) Insert common plastic scraper or spatula between top edge of Label and body.
- 2) Use a tool to peel off label by pinching it with your fingers.
- 3) Hold label with your fingers and peel it off.

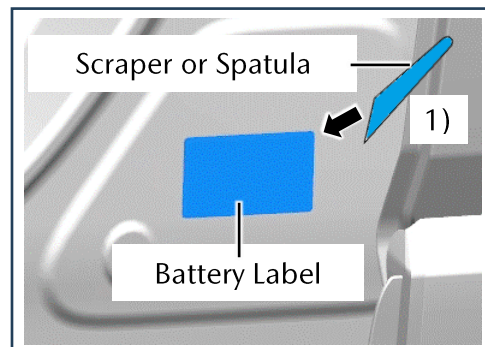

2. Clean the surface vehicle body where the Battery Label was attached.

- a. Apply parts cleaner(main ingredient: ethanol, isopropyl alcohol) to a microfiber cloth.
- b. Clean the body surface where the Battery Label was attached (remove residue 100%)

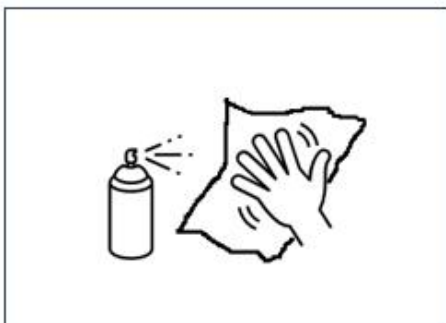

3. Install one Battery Label on B-Pillar

**CAUTION:** Do not touch the label adhesive before applying.

- a. Attach battery label so that edge line is parallel (//) to end of curve line as shown in the figure below. NOTE: make sure to place approximately distances as below.

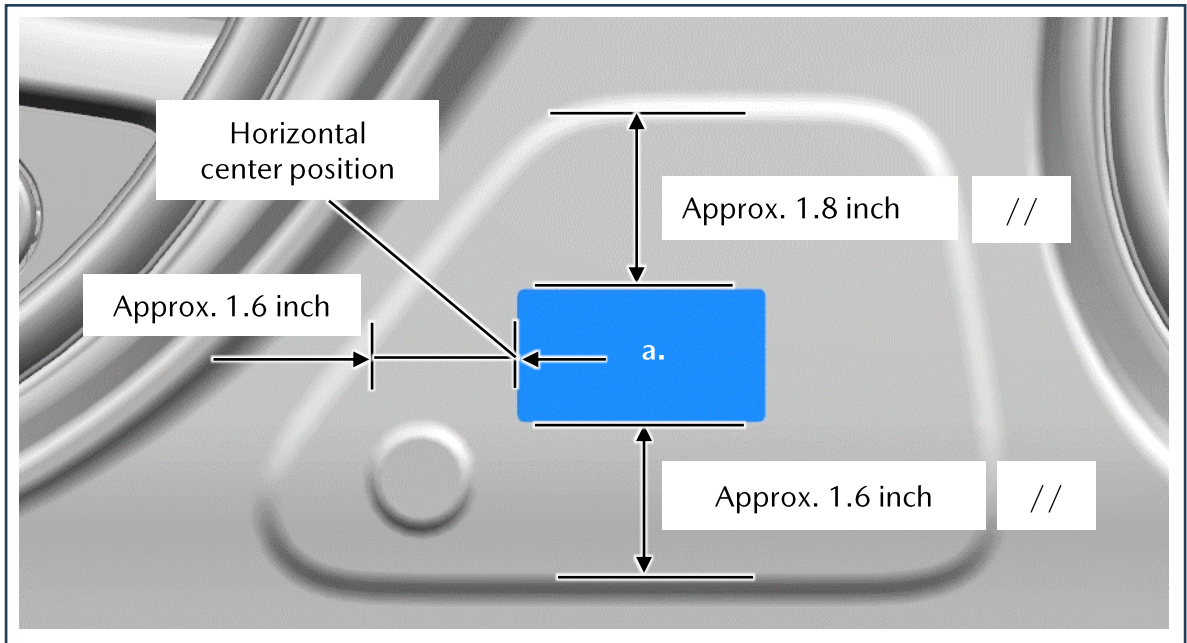

4. **PHOTO #1 – Installation of NEW label on B-Pillar**

- Take a picture of the area where the new Battery Label was placed.

**NOTE:** The printed contents (VIN and QR code) on the photographed battery label must be readable.

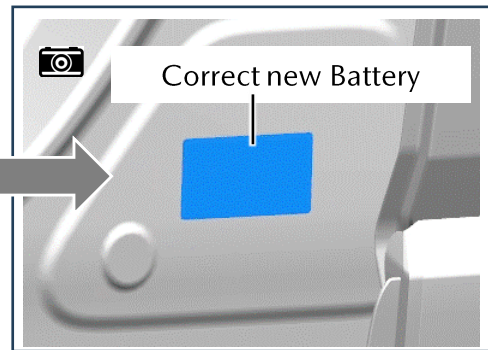
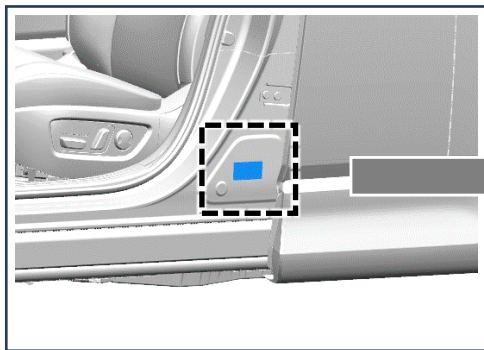

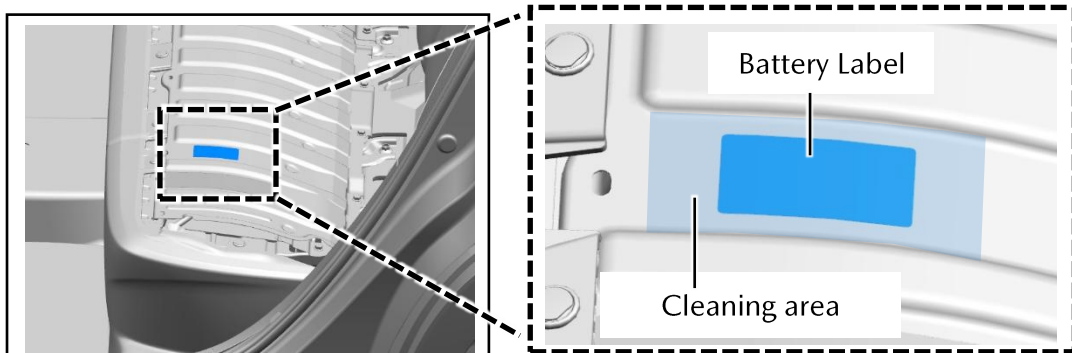

PHOTO #2 example: OLD and NEW label – clear photo – do not use black & white or pdf.



[ Hybrid Battery NEW Label placement on top of original label SECTION]

5. Remove the rear seat cushion according to procedure in Workshop Manual. ([See REAR SEAT CUSHION REMOVAL/INSTALLATION.](#))
6. Use a microfiber cloth to clean and degrease the area around the Battery label surface.  
\*Cleaning area is light blue as follows: 



7. Attach NEW Battery label on top of original Battery label as shown in the diagram below.  
**CAUTION:** Do not touch the label adhesive before applying.

a.	<b><u>Do not remove the old label.</u></b> Attach the NEW label approximately <b>1 inch</b> to the right <b>OVERLAPPING</b> the old label. The left edges of the original label will be visible ( <b>SEE PHOTO #3 EXAMPLE BELOW FOR PLACEMENT</b> ). <b>The start of the new label is about 1/4" to the right of the bar.</b>
----	---

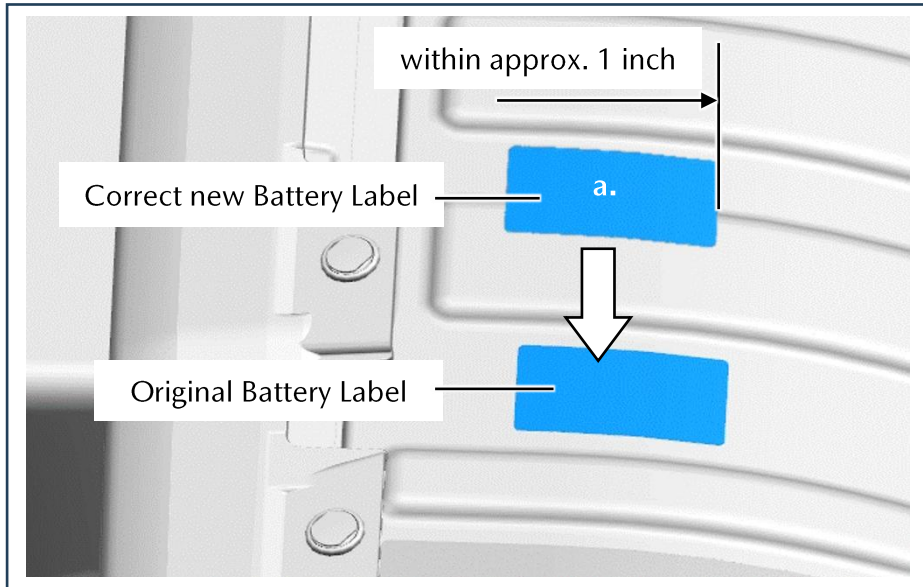

8. **PHOTO #3 – NEW label on top of Hybrid Battery**

- Take a picture of the area where the NEW Battery Label is placed.

**NOTE:** The printed contents (**VIN and bottom right QR code**) on the photographed battery label must be readable.

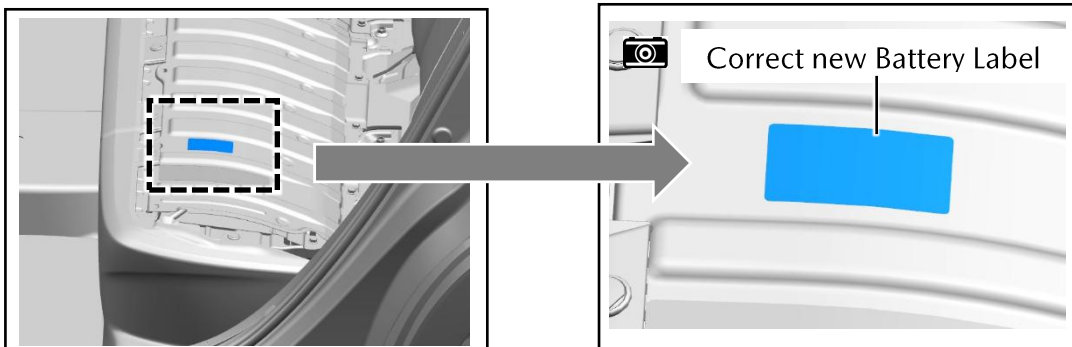

PHOTO # 3 example: Existing label – clear photo – do not use black & white or pdf



9. Install the rear seat cushion according to procedure in Workshop Manual. ([See REAR SEAT CUSHION REMOVAL/INSTALLATION.](#))



**NO GOOD - UNACCEPTABLE PHOTOS – IF ANY OF YOUR PHOTOS ARE SIMILAR TO BELOW, YOUR CLAIM WILL NOT BE PAID AND THE VEHICLE WILL NEED TO RETURN FOR A RE-REPAIR AND NEW LABELS ADDED AT THE DEALER EXPENSE WITH GREAT CUSTOMER INCONVENIENCE.**

**BATTERY - PHOTO IS CUT OFF - UNACCEPTABLE**

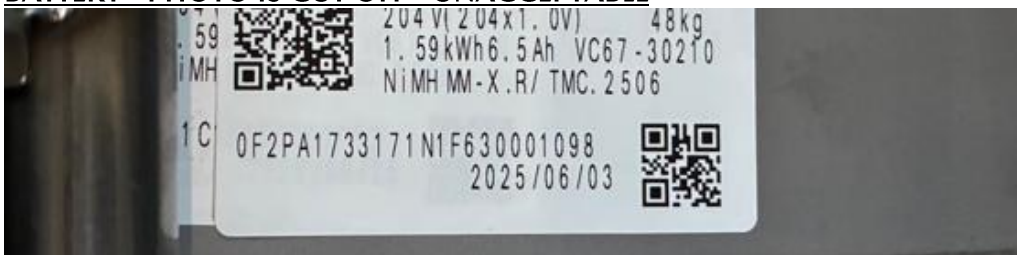

**LABEL IS ON TOP OF OTHER LABEL, CANNOT READ QR CODES - UNACCEPTABLE**

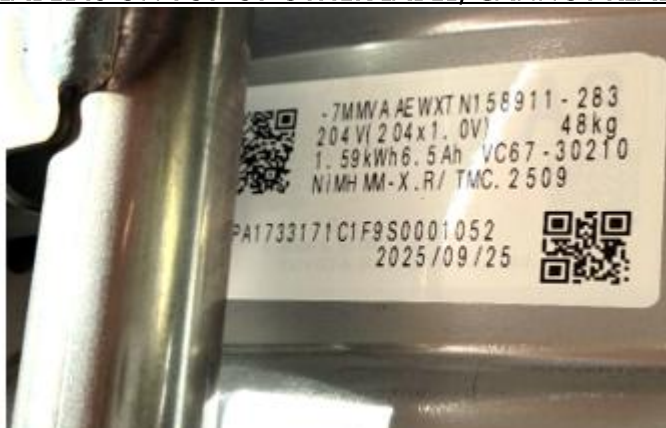

BLURRY AND OFF CENTER - UNACCEPTABLE



UNACCEPTABLE



CANNOT READ QR CODES, TOO CLOSE - UNACCEPTABLE



-----END OF SECTION B-----

## GO TO SECTION C. CAMPAIGN LABEL INSTALLATION

### C. Campaign Label Installation AND Emission Proof of Correction (ONLY if needed in certain states)

1. Fill out a Black "Campaign Label" (9999-95-055A-06) with Campaign #: "8026C", your dealer code, and the repair date. **It is OK to bundle multiple campaigns on one label as long as each campaign is legible as Mazda vehicles may have more than 1 campaign.** Use more than one label if necessary.

CAMPAIGN LABEL

CAMPAIGN NO: \_\_\_\_\_

DEALER CODE: \_\_\_\_\_

DATE:        //    //

PIN 9999-95-055A-06

1328b

2. Affix it to the hood as shown. If you cannot place the label here, the radiator support, firewall or driver door jamb are acceptable locations:

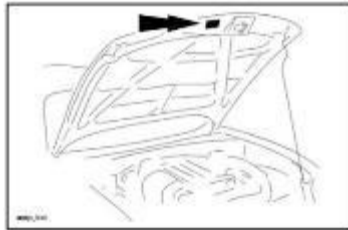

**ONLY IF VEHICLE IS REGISTERED IN CALIFORNIA AND MASSACHUSETTES: CERTAIN U.S. STATES ONLY – PLEASE MAKE SURE THE CUSTOMER RECEIVES THIS LABEL AS FILLED OUT BY YOUR DEALER SERVICE STAFF**

- \* California Department of Motor Vehicles and the Commonwealth of Massachusetts, in conjunction with the California Air Resources Board and the Environmental Protection Agency for the State of Massachusetts, have implemented the Registration Renewal/Recall Tie-In Program, which requires the completion of Emission Recalls prior to registration renewal. Mazda dealers must provide customers a Vehicle Emission Recall – Proof of Correction Certificate (p/n 9999-95-ERPC-99) up on completion of the recall.

mazda Vehicle Emission Recall - Proof of Correction

Vehicle Identification Number

License Number    Make    Year Model    Body Type

Manufacturer MAZDA NORTH AMERICAN OPERATIONS    Fiscal Number

The above described vehicle has been repaired, modified and/or equipped with new emission control devices to meet applicable California Emission Control Laws (or California emission control laws adopted by your state or commonwealth)

Dealer's Name    Address, City, State and Zip

Date    Dealer's Authorized Signature

Return this certificate and return to the Department of Motor Vehicle (DMV) if it is required by the DMV.

## END OF REPAIR PROCEDURE