

Technical Service Bulletin

Mazda North American Operations
Irvine, CA 92618-2922



Subject: A/C INOPERATIVE WITH DTCS P0D6D:00 AND/OR U0605:00 AND A/C HIGH-VOLTAGE FUSE OPEN	Bulletin No.: 07-002/26
	Last Issued : 06/16/2026

BULLETIN NOTES

Customers having this concern should have their vehicle repaired using the following repair procedure.

Previous TSBs: 07-002/26	Date(s) Issued: 06/10/26
--	--

APPLICABLE MODEL(S)/VINS

2024-2026 CX-90 PHEV with VINS lower than JM3KK*****350779 (produced before January 20, 2026)

2025-2026 CX-70 PHEV with VINS lower than JM3KJ*****378756 (produced before January 20, 2026)

NOTE: MASH authorization is required for all parts replacement except A/C compressor. Review Mazda Warranty Policies and Procedures Policy No.:3.28 for details.

DESCRIPTION

Some customers may complain that the A/C does not cool. This concern may be due to an internal short circuit in the A/C compressor, caused by an overcurrent. On some vehicles, the A/C high-voltage fuse opens and DTC P0D6D is stored.

DTC	System malfunction location
P0D6D:00-PCM	Electric compressor (voltage sensor): Low input
U0605:00-PCM	LIN communication system: Communication error between electric compressor and PCM

Other related DTCs	System malfunction location
P0EC5:00-PCM	Error signal received from electric compressor
P0AA6:00-PCM	High-voltage insulation malfunction: Decrease in vehicle insulation resistance

To eliminate this concern, the electrical circuit of the A/C compressor has been modified to prevent a short circuit even if an overcurrent occurs.

Customers having this concern should have their vehicle repaired using the following repair procedure.

CONSUMER NOTICE: The information and instructions in this bulletin are intended for use by skilled technicians. Mazda technicians utilize the proper tools/ equipment and take training to correctly and safely maintain Mazda vehicles. These instructions should not be performed by "do-it-yourselfers." Customers should not assume this bulletin applies to their vehicle or that their vehicle will develop the described concern. To determine if the information applies, customers should contact their nearest authorized Mazda dealership. Mazda North American Operations reserves the right to alter the specifications and contents of this bulletin without obligation or advance notice. All rights reserved. No part of this bulletin may be reproduced in any form or by any means, electronic or mechanical--including photocopying and recording and the use of any kind of information storage and retrieval system ---without permission in writing.

REPAIR PROCEDURE

WARNING: Exposure to high-voltage electrical systems and battery components can cause severe injury, electrical burns, shock, arc flash events, and death if handled improperly. All service, repair, diagnostics, disabling, re-energizing, and handling of high-voltage systems and components on hybrid, plug-in hybrid (PHEV), and battery electric vehicles (EV) **must** be performed **only** by technicians who have completed high-voltage training and hold the appropriate certification/qualification for high-voltage work.

IMPORTANT: This repair **requires** Master Certification and completion of **Course 40086ILT - High Voltage Battery Repair ILT**.

1. Verify the customer concern.

Is A/C inoperative AND DTC P0D6D:00 stored?

- **YES:** Go to next step.
- **NO:** This TSB does not apply. If the A/C is inoperative without DTC P0D6D, diagnose using normal MGSS troubleshooting.

2. Replace the A/C compressor with an updated one according to the procedure in MGSS (ELECTRIC COMPRESSOR REMOVAL/INSTALLATION [e-SKYACTIV PHEV]).

After the compressor replacement, is DTC P0D6D still stored?

YES: Go to next step.

NO: Verify the vehicle is repaired.

CONSUMER NOTICE: The information and instructions in this bulletin are intended for use by skilled technicians. Mazda technicians utilize the proper tools/ equipment and take training to correctly and safely maintain Mazda vehicles. These instructions should not be performed by "do-it-yourselfers." Customers should not assume this bulletin applies to their vehicle or that their vehicle will develop the described concern. To determine if the information applies, customers should contact their nearest authorized Mazda dealership. Mazda North American Operations reserves the right to alter the specifications and contents of this bulletin without obligation or advance notice. All rights reserved. No part of this bulletin may be reproduced in any form or by any means, electronic or mechanical---including photocopying and recording and the use of any kind of information storage and retrieval system ---without permission in writing.

3. Check the continuity of the high-voltage circuit including the A/C fuse.

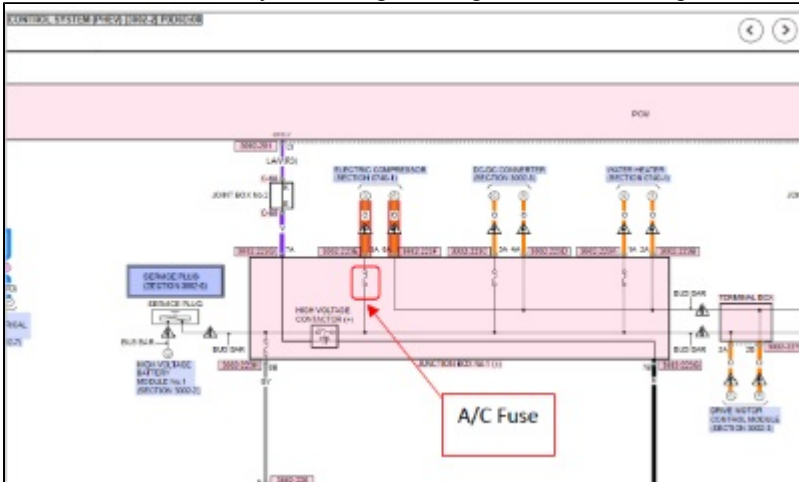

- a. Safely place the vehicle on a lift.
- b. Move the driver's seat to the most forward position to make it easy to access the service plug.
- c. Confirm the items below.
 - The high-voltage battery is not being charged.
 - Deactivate Connected Vehicle Services (**Connected Vehicle Maintenance Mode**) (SERVICE CAUTIONS FOR VEHICLES WITH TELEMATICS COMMUNICATION SYSTEM)
- d. Turn off the vehicle (IG-OFF).
- e. Disconnect the 12V battery negative terminal.
- f. Wear insulated gloves to remove the service plug ([SERVICE PLUG REMOVAL/INSTALLATION](#)).
- g. Raise the vehicle.
- h. Remove the Front Under Cover No.3 and Floor Under Cover (Left side).
- i. Wait for 10 minutes after removing the service plug before continuing to next step.

	MASH Authorization Request (MAR) - PHEV Internal Battery Repair Form
	<p>Click here for MASH Authorization Form</p> <p>This form is intended to document voltage and resistance measurements for attachment to the Siebel file in support of MASH authorization through the online MAR process. The QR code can be scanned to enter and save measurements into the form on a cell phone.</p>

- j. Wear insulated gloves to remove the terminal cover.



CONSUMER NOTICE: The information and instructions in this bulletin are intended for use by skilled technicians. Mazda technicians utilize the proper tools/ equipment and take training to correctly and safely maintain Mazda vehicles. These instructions should not be performed by "do-it-yourselfers." Customers should not assume this bulletin applies to their vehicle or that their vehicle will develop the described concern. To determine if the information applies, customers should contact their nearest authorized Mazda dealership. Mazda North American Operations reserves the right to alter the specifications and contents of this bulletin without obligation or advance notice. All rights reserved. No part of this bulletin may be reproduced in any form or by any means, electronic or mechanical--including photocopying and recording and the use of any kind of information storage and retrieval system ---without permission in writing.

k. Measure the voltage between the terminals, and between each terminal and body ground to verify that all three (3) measurements indicate zero volts. If greater than zero volts, wait a little longer until voltage is zero.



l. Disconnect all three (3) high-voltage cables at the front of the high-voltage battery pack.



m. Measure the resistance between the positive terminal of the high-voltage connector and the terminal box (+) side shown below.

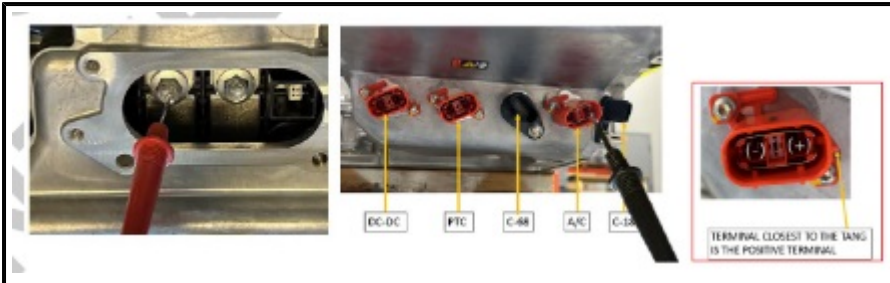

- Good fuse measurement will be 1 ohm or less.
- Blown fuse measurement will be open (OL).

CONSUMER NOTICE: The information and instructions in this bulletin are intended for use by skilled technicians. Mazda technicians utilize the proper tools/ equipment and take training to correctly and safely maintain Mazda vehicles. These instructions should not be performed by "do-it-yourselfers." Customers should not assume this bulletin applies to their vehicle or that their vehicle will develop the described concern. To determine if the information applies, customers should contact their nearest authorized Mazda dealership. Mazda North American Operations reserves the right to alter the specifications and contents of this bulletin without obligation or advance notice. All rights reserved. No part of this bulletin may be reproduced in any form or by any means, electronic or mechanical---including photocopying and recording and the use of any kind of information storage and retrieval system ---without permission in writing.

n. Measure the resistance between terminal box (+) and the positive high-voltage connector for the DCDC Converter and the PTC Heater.

- Good fuse measurements will be 1 ohm or less.

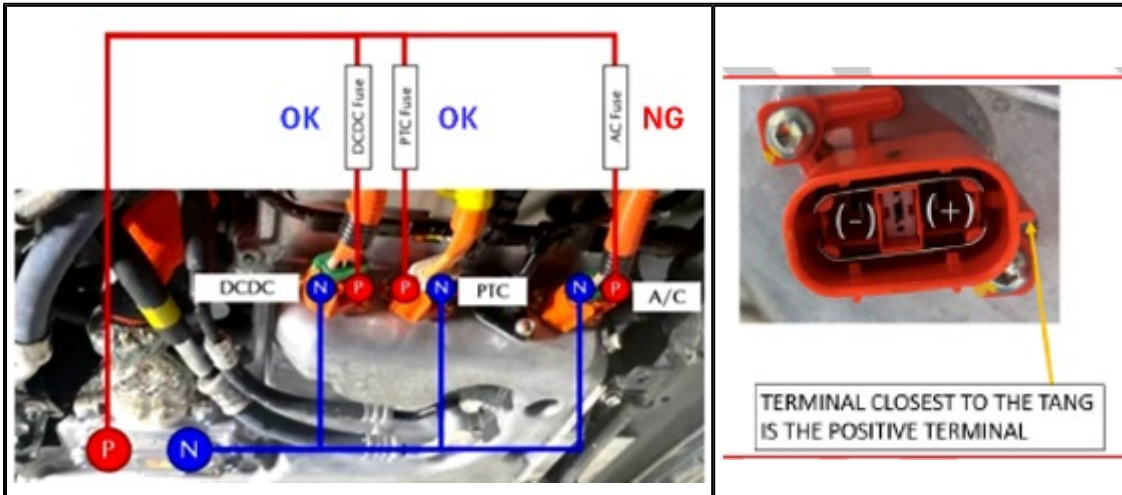

Is the A/C high-voltage fuse open?

YES: Continue to step 4.

NO: This TSB does NOT apply. Continue diagnosis using MGSS.

4. Replace Junction Box 1 (+) according to the following procedure.

Note: the tutorial video linked below is available for reference.



A/C Fuse Replacement Tutorial Video

JUNCTION BOX ASSY FR-LH REMOVAL

WARNING: If the following sign  is indicated in the procedure, high-voltage components (live parts with over 50V) are involved. Make sure to take the necessary actions before servicing an electric vehicle, or you may get an electric shock that can result in a serious injury or death in the worst case. Before servicing the electric vehicle, refer to the (HIGH-VOLTAGE SERVICE CAUTIONS) in MGSS and make sure to take all necessary actions to start services This repair can only be performed by properly trained technicians.

Items to be prepared

CONSUMER NOTICE: The information and instructions in this bulletin are intended for use by skilled technicians. Mazda technicians utilize the proper tools/ equipment and take training to correctly and safely maintain Mazda vehicles. These instructions should not be performed by "do-it-yourselfers." Customers should not assume this bulletin applies to their vehicle or that their vehicle will develop the described concern. To determine if the information applies, customers should contact their nearest authorized Mazda dealership. Mazda North American Operations reserves the right to alter the specifications and contents of this bulletin without obligation or advance notice. All rights reserved. No part of this bulletin may be reproduced in any form or by any means, electronic or mechanical---including photocopying and recording and the use of any kind of information storage and retrieval system ---without permission in writing.

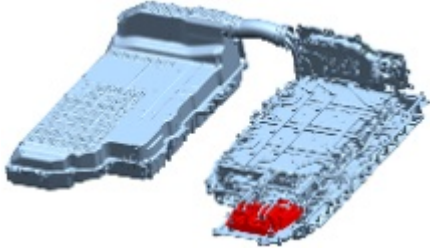

CONSUMER NOTICE: The information and instructions in this bulletin are intended for use by skilled technicians. Mazda technicians utilize the proper tools/ equipment and take training to correctly and safely maintain Mazda vehicles. These instructions should not be performed by "do-it-yourselfers." Customers should not assume this bulletin applies to their vehicle or that their vehicle will develop the described concern. To determine if the information applies, customers should contact their nearest authorized Mazda dealership. Mazda North American Operations reserves the right to alter the specifications and contents of this bulletin without obligation or advance notice. All rights reserved. No part of this bulletin may be reproduced in any form or by any means, electronic or mechanical---including photocopying and recording and the use of any kind of information storage and retrieval system ---without permission in writing.

Target parts	Location (red part)
	

[Non-reusable parts]

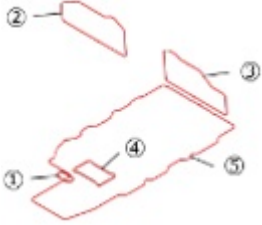
Part number	Location (red part)
<p>(1) KBB4-302K5 (2) KBB3-302K3 (3) KBB4-302K3 (4) KBB4-302K8 (5) KBB4-302K2</p>	

NOTE: When performing the procedure below, use **only** hand tools and calibrated torque wrenches for all internal work and reassembly operations.

a. Remove the HV Battery. Refer to [HIGH-VOLTAGE BATTERY REMOVAL/INSTALLATION](#)

	<p>High Voltage Battery Replacement Tutorial Video</p>
---	--

b. Remove the COVER ASSY-BAT . Refer to COVER ASSY-BATTERY LEFT SIDE.

CONSUMER NOTICE: The information and instructions in this bulletin are intended for use by skilled technicians. Mazda technicians utilize the proper tools/ equipment and take training to correctly and safely maintain Mazda vehicles. These instructions should not be performed by "do-it-yourselfers." Customers should not assume this bulletin applies to their vehicle or that their vehicle will develop the described concern. To determine if the information applies, customers should contact their nearest authorized Mazda dealership. Mazda North American Operations reserves the right to alter the specifications and contents of this bulletin without obligation or advance notice. All rights reserved. No part of this bulletin may be reproduced in any form or by any means, electronic or mechanical---including photocopying and recording and the use of any kind of information storage and retrieval system ---without permission in writing.

c. Check the coverage area of the insulating mat .

NOTE: The insulating mat was included in the HV Safety kit auto shipped to dealers (49HV21KIT2) and is available separately from the Mazda Tool & Equipment site (230-JDI-IM).

WARNING: The insulating mat must always cover parts other than the parts to be worked on.

*Red: parts to be worked on.

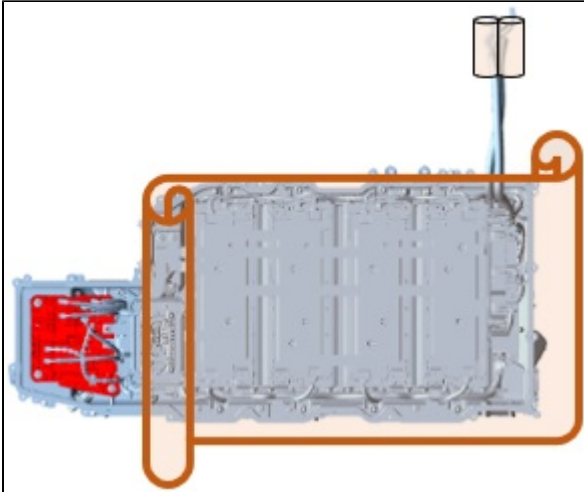

d. Remove the PLUG ASSY-SERVICE . Refer to PLUG ASSY-SERVICE REMOVAL.

e. Remove the BUSS BARS shown in the images.

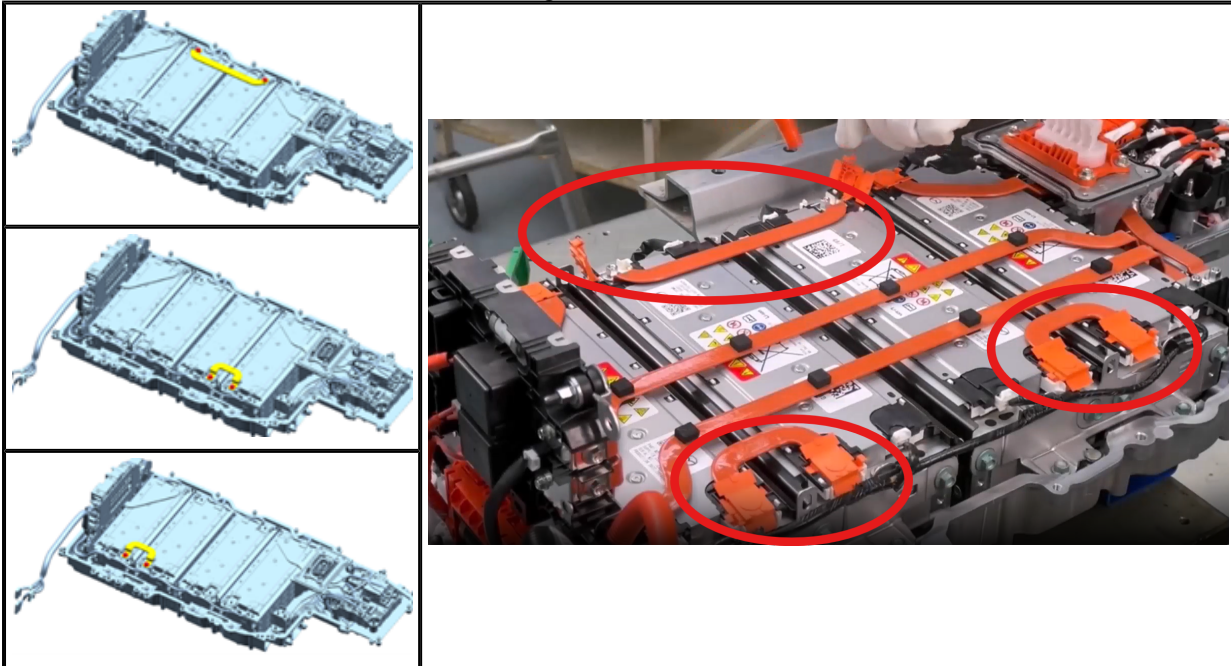

CONSUMER NOTICE: The information and instructions in this bulletin are intended for use by skilled technicians. Mazda technicians utilize the proper tools/ equipment and take training to correctly and safely maintain Mazda vehicles. These instructions should not be performed by "do-it-yourselfers." Customers should not assume this bulletin applies to their vehicle or that their vehicle will develop the described concern. To determine if the information applies, customers should contact their nearest authorized Mazda dealership. Mazda North American Operations reserves the right to alter the specifications and contents of this bulletin without obligation or advance notice. All rights reserved. No part of this bulletin may be reproduced in any form or by any means, electronic or mechanical--including photocopying and recording and the use of any kind of information storage and retrieval system ---without permission in writing.

- 1) Lift the terminal covers of battery BUSS BARS and remove the nuts to remove the BUSS BARS.
Tightening torque when installing: 6.8 ± 1.1 ft·lb (9.3 ± 1.5 N·m)



- 2) Close the terminal covers after removing each BUSS BAR.
3) Remove the 3 small BUSS BARS between Junction Box 1 (+) and the Terminal Block.
Tightening torque when installing: 6.8 ± 1.1 ft·lb (9.3 ± 1.5 N·m)

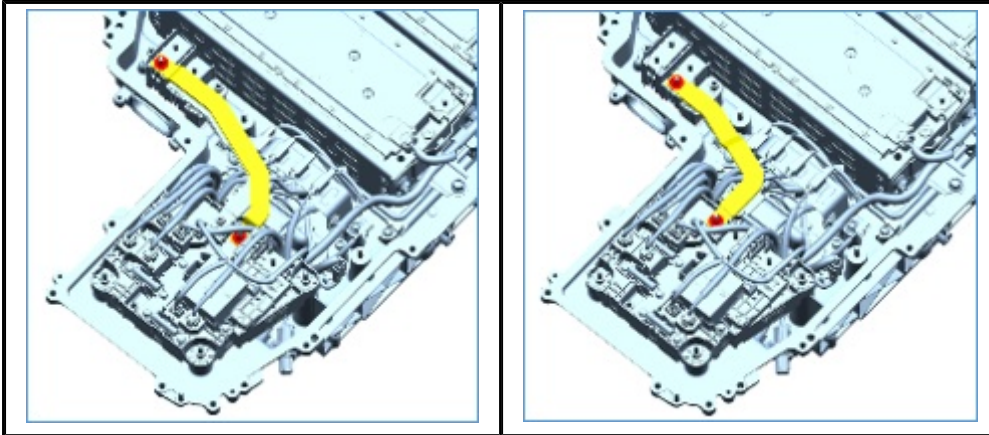

- f. Remove the JUNCTION BOX ASSY FR-LH.

- 1) Disconnect the connector and harness clip.

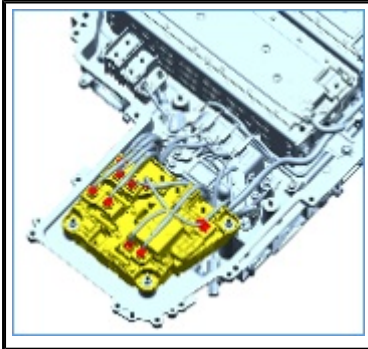

Reference: Connector shape and mounting position.

CONSUMER NOTICE: The information and instructions in this bulletin are intended for use by skilled technicians. Mazda technicians utilize the proper tools/ equipment and take training to correctly and safely maintain Mazda vehicles. These instructions should not be performed by "do-it-yourselfers." Customers should not assume this bulletin applies to their vehicle or that their vehicle will develop the described concern. To determine if the information applies, customers should contact their nearest authorized Mazda dealership. Mazda North American Operations reserves the right to alter the specifications and contents of this bulletin without obligation or advance notice. All rights reserved. No part of this bulletin may be reproduced in any form or by any means, electronic or mechanical---including photocopying and recording and the use of any kind of information storage and retrieval system ---without permission in writing.

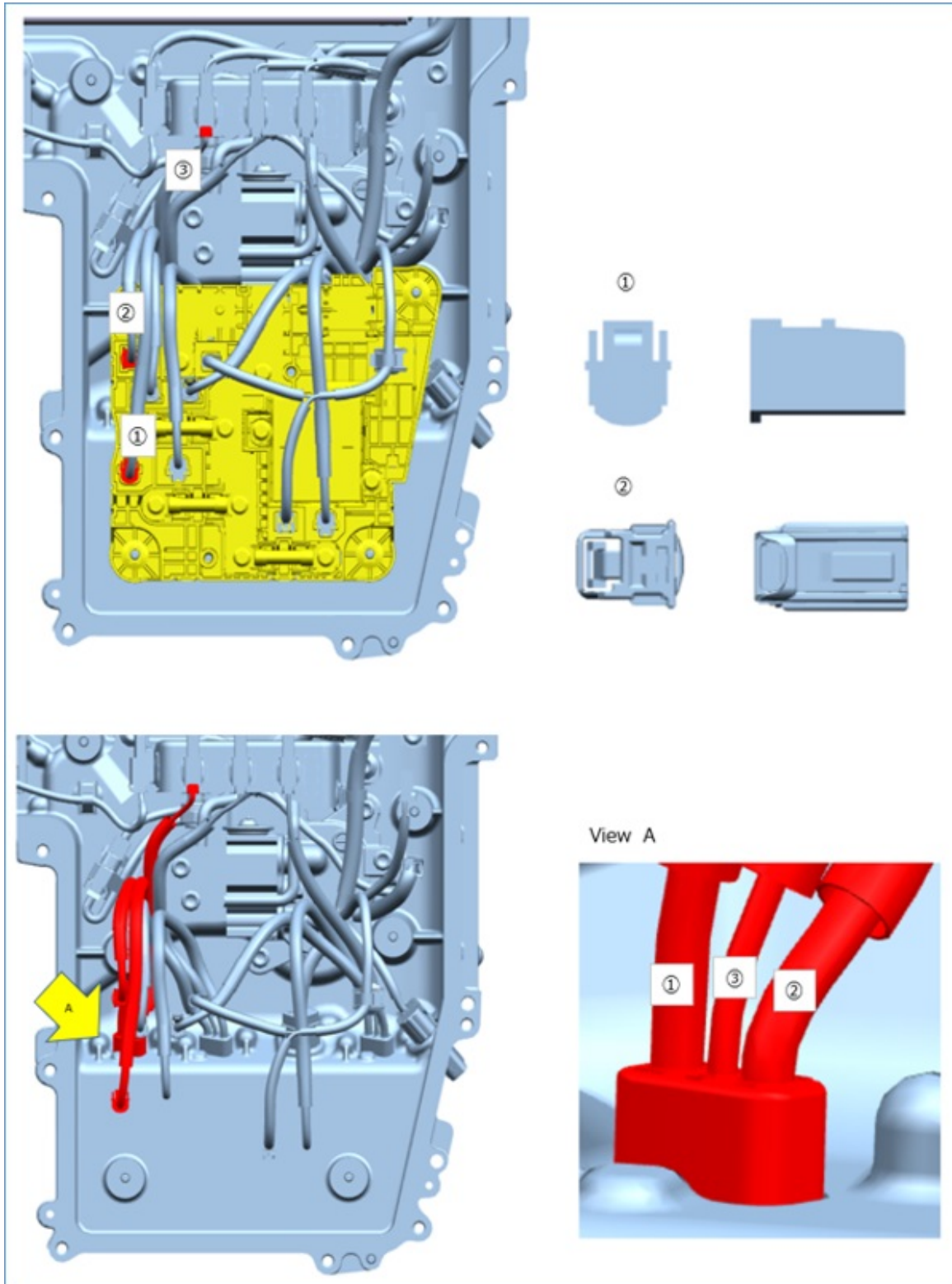

CONSUMER NOTICE: The information and instructions in this bulletin are intended for use by skilled technicians. Mazda technicians utilize the proper tools/ equipment and take training to correctly and safely maintain Mazda vehicles. These instructions should not be performed by "do-it-yourselfers." Customers should not assume this bulletin applies to their vehicle or that their vehicle will develop the described concern. To determine if the information applies, customers should contact their nearest authorized Mazda dealership. Mazda North American Operations reserves the right to alter the specifications and contents of this bulletin without obligation or advance notice. All rights reserved. No part of this bulletin may be reproduced in any form or by any means, electronic or mechanical---including photocopying and recording and the use of any kind of information storage and retrieval system ---without permission in writing.

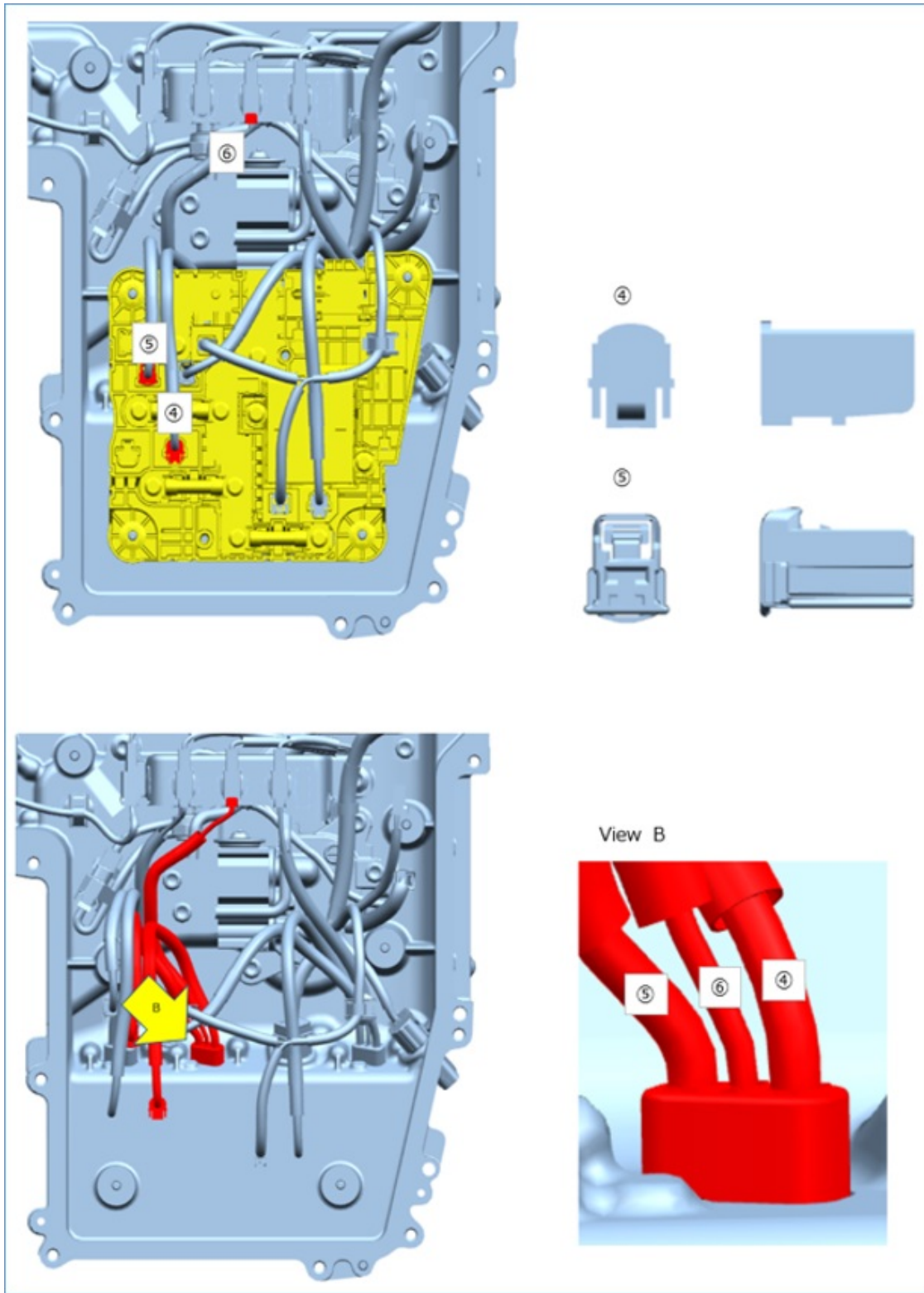

CONSUMER NOTICE: The information and instructions in this bulletin are intended for use by skilled technicians. Mazda technicians utilize the proper tools/ equipment and take training to correctly and safely maintain Mazda vehicles. These instructions should not be performed by "do-it-yourselfers." Customers should not assume this bulletin applies to their vehicle or that their vehicle will develop the described concern. To determine if the information applies, customers should contact their nearest authorized Mazda dealership. Mazda North American Operations reserves the right to alter the specifications and contents of this bulletin without obligation or advance notice. All rights reserved. No part of this bulletin may be reproduced in any form or by any means, electronic or mechanical--including photocopying and recording and the use of any kind of information storage and retrieval system ---without permission in writing.

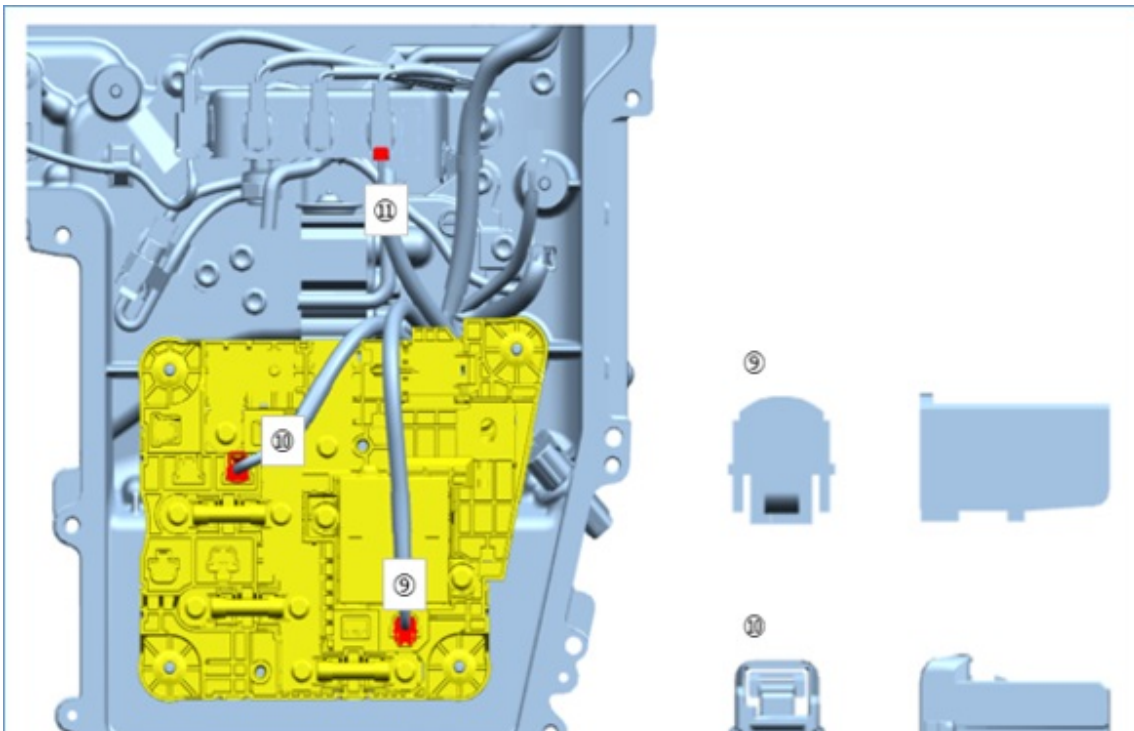
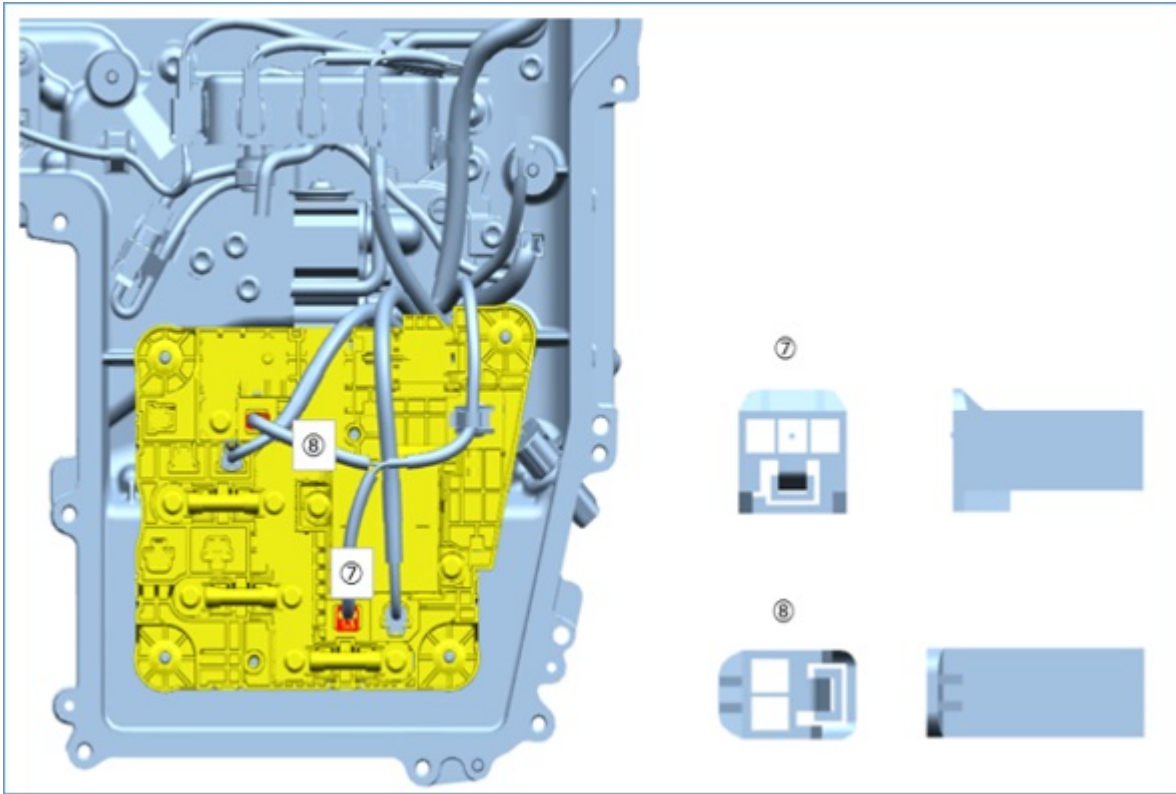

CONSUMER NOTICE: The information and instructions in this bulletin are intended for use by skilled technicians. Mazda technicians utilize the proper tools/ equipment and take training to correctly and safely maintain Mazda vehicles. These instructions should not be performed by "do-it-yourselfers." Customers should not assume this bulletin applies to their vehicle or that their vehicle will develop the described concern. To determine if the information applies, customers should contact their nearest authorized Mazda dealership. Mazda North American Operations reserves the right to alter the specifications and contents of this bulletin without obligation or advance notice. All rights reserved. No part of this bulletin may be reproduced in any form or by any means, electronic or mechanical---including photocopying and recording and the use of any kind of information storage and retrieval system ---without permission in writing.



2) Remove Junction Box 1 (+).

Tightening torque when installing: 6.8 ± 1.1 ft·lb (9.3 ± 1.5 N·m)



JUNCTION BOX ASSY FR-LH INSTALLATION

g. Install it in reverse to the removal procedure



h. Verify the repair and confirm that there are no DTCs stored and no abnormal warning lights present.

CONSUMER NOTICE: The information and instructions in this bulletin are intended for use by skilled technicians. Mazda technicians utilize the proper tools/ equipment and take training to correctly and safely maintain Mazda vehicles. These instructions should not be performed by "do-it-yourselfers." Customers should not assume this bulletin applies to their vehicle or that their vehicle will develop the described concern. To determine if the information applies, customers should contact their nearest authorized Mazda dealership. Mazda North American Operations reserves the right to alter the specifications and contents of this bulletin without obligation or advance notice. All rights reserved. No part of this bulletin may be reproduced in any form or by any means, electronic or mechanical---including photocopying and recording and the use of any kind of information storage and retrieval system ---without permission in writing.



COVER ASSY-BATTERY LEFT SIDE REMOVAL

WARNING: If the following sign  is indicated in the procedure, high-voltage components (live parts with over 50V) are involved. Make sure to take the necessary actions before servicing an electric vehicle, or you may get an electric shock that can result in a serious injury or death in the worst case. Before servicing the electric vehicle, refer to the (HIGH-VOLTAGE SERVICE CAUTIONS) in MGSS and make sure to take all necessary actions to start services This repair can only be performed by properly trained technicians.

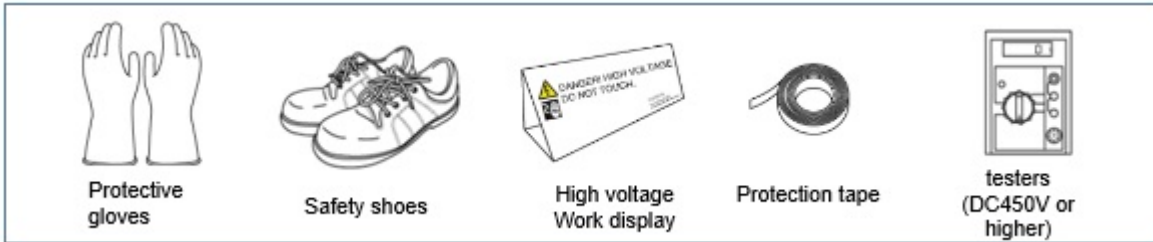
Items to be prepared



SST - 49JP-046A0 - LIB_AIR_TIGHT_TESTER_PHEV-2

IMAGE	NAME
	COUPLER A
	COUPLER B
	GAGE SET

Important: Once MASH has been approved for this repair. A loaner tool kit will be shipped overnight. Once repairs are complete the tool **must** be returned using the supplied return label.

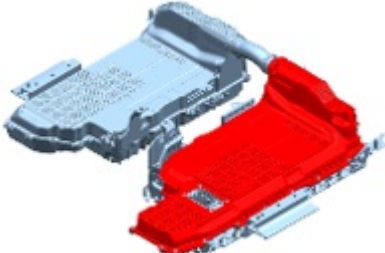
Target parts	Location (red part)
	

CONSUMER NOTICE: The information and instructions in this bulletin are intended for use by skilled technicians. Mazda technicians utilize the proper tools/ equipment and take training to correctly and safely maintain Mazda vehicles. These instructions should not be performed by "do-it-yourselfers." Customers should not assume this bulletin applies to their vehicle or that their vehicle will develop the described concern. To determine if the information applies, customers should contact their nearest authorized Mazda dealership. Mazda North American Operations reserves the right to alter the specifications and contents of this bulletin without obligation or advance notice. All rights reserved. No part of this bulletin may be reproduced in any form or by any means, electronic or mechanical---including photocopying and recording and the use of any kind of information storage and retrieval system ---without permission in writing.

[Non-reusable parts]

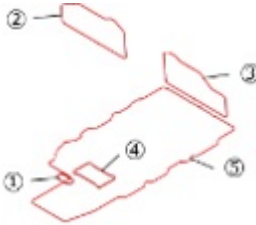
Part number	Location (red part)
(1) KBB4-302K5 (2) KBB3-302K3 (3) KBB4-302K3 (4) KBB4-302K8 (5) KBB4-302K2	

NOTE: When performing the procedure below, use **only** hand tools and calibrated torque wrenches for all internal work and reassembly operations.

CONSUMER NOTICE: The information and instructions in this bulletin are intended for use by skilled technicians. Mazda technicians utilize the proper tools/ equipment and take training to correctly and safely maintain Mazda vehicles. These instructions should not be performed by "do-it-yourselfers." Customers should not assume this bulletin applies to their vehicle or that their vehicle will develop the described concern. To determine if the information applies, customers should contact their nearest authorized Mazda dealership. Mazda North American Operations reserves the right to alter the specifications and contents of this bulletin without obligation or advance notice. All rights reserved. No part of this bulletin may be reproduced in any form or by any means, electronic or mechanical---including photocopying and recording and the use of any kind of information storage and retrieval system ---without permission in writing.

- 1. Measure the voltage [M].
Voltage between terminals: 0V

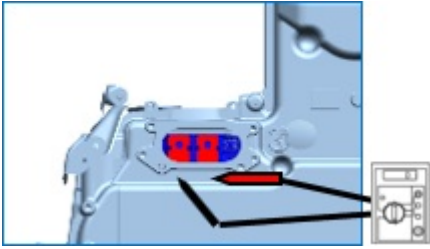

- 2. Measure the voltage [M].
Voltage between terminals: 0V



- 3. Apply insulating tape.

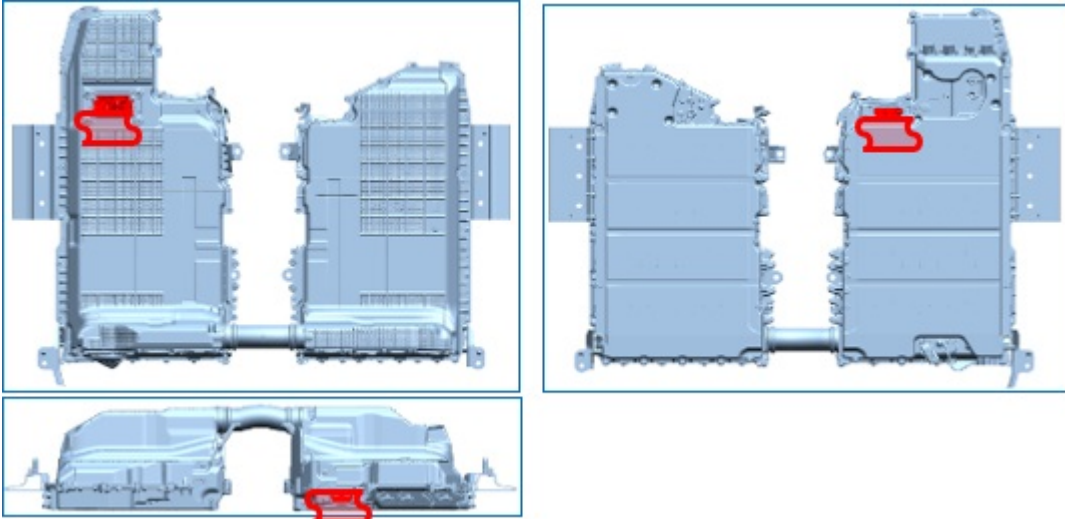

CONSUMER NOTICE: The information and instructions in this bulletin are intended for use by skilled technicians. Mazda technicians utilize the proper tools/ equipment and take training to correctly and safely maintain Mazda vehicles. These instructions should not be performed by "do-it-yourselfers." Customers should not assume this bulletin applies to their vehicle or that their vehicle will develop the described concern. To determine if the information applies, customers should contact their nearest authorized Mazda dealership. Mazda North American Operations reserves the right to alter the specifications and contents of this bulletin without obligation or advance notice. All rights reserved. No part of this bulletin may be reproduced in any form or by any means, electronic or mechanical---including photocopying and recording and the use of any kind of information storage and retrieval system ---without permission in writing.

4. Remove the PLATE ASSY.
 a. Remove the bolts.
 Tightening torque when installing: 6.8 ± 1.1 ft·lb (9.3 ± 1.5 N·m)

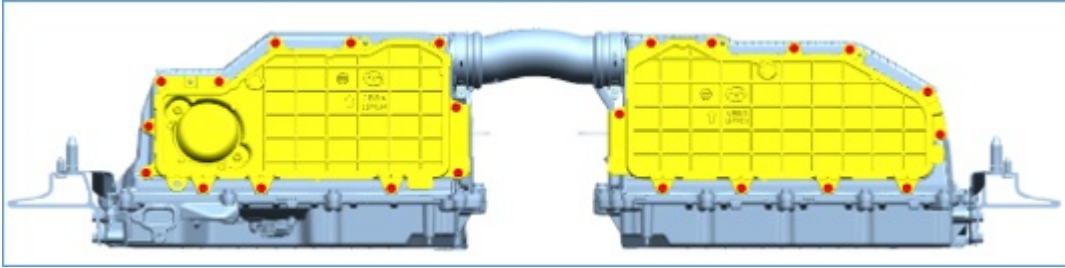

5. Disconnect the CABLE-MODULE [W].

- a. Remove the nut [W].
 Tightening torque when installing: 8.0 ± 1.1 ft·lb (10.8 ± 1.5 N·m)

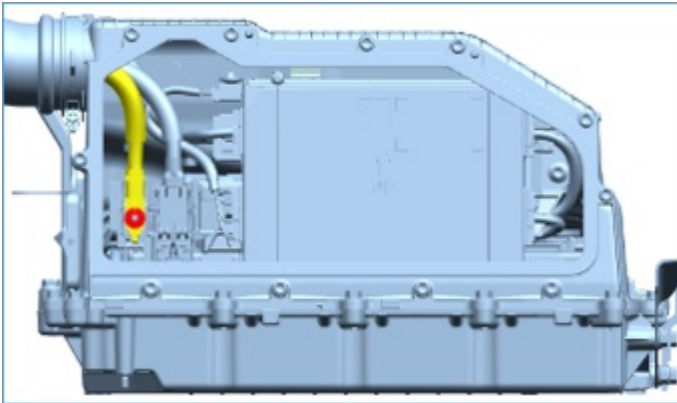

- b. Apply insulating tape [W].

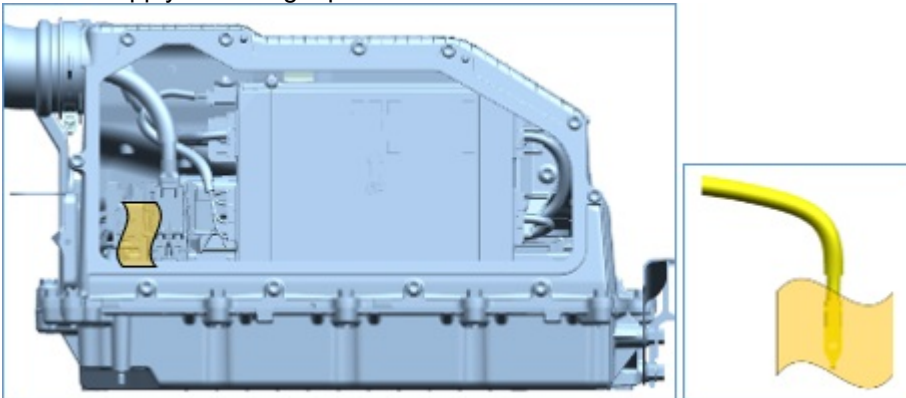

CONSUMER NOTICE: The information and instructions in this bulletin are intended for use by skilled technicians. Mazda technicians utilize the proper tools/ equipment and take training to correctly and safely maintain Mazda vehicles. These instructions should not be performed by "do-it-yourselfers." Customers should not assume this bulletin applies to their vehicle or that their vehicle will develop the described concern. To determine if the information applies, customers should contact their nearest authorized Mazda dealership. Mazda North American Operations reserves the right to alter the specifications and contents of this bulletin without obligation or advance notice. All rights reserved. No part of this bulletin may be reproduced in any form or by any means, electronic or mechanical---including photocopying and recording and the use of any kind of information storage and retrieval system ---without permission in writing.

c. Detach the harness clip [W].

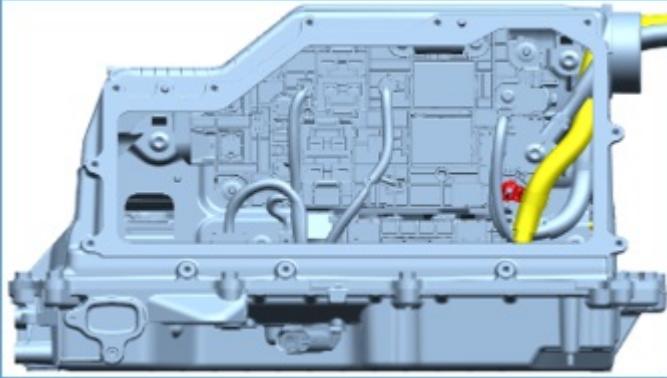

d. Remove the nut [W].
Tightening torque when installing: 8.0 ± 1.1 ft·lb (10.8 ± 1.5 N·m)

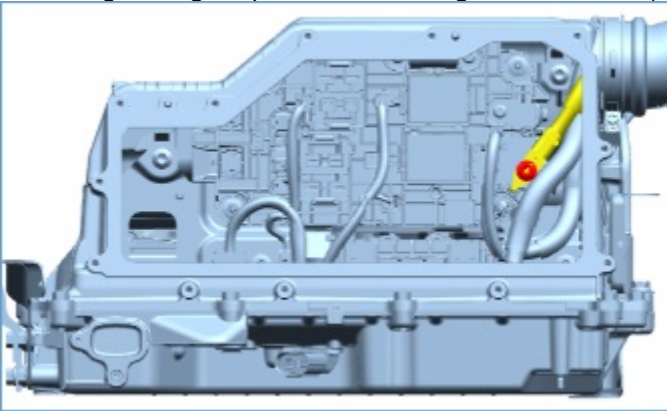

e. Apply insulating tape [W].



CONSUMER NOTICE: The information and instructions in this bulletin are intended for use by skilled technicians. Mazda technicians utilize the proper tools/ equipment and take training to correctly and safely maintain Mazda vehicles. These instructions should not be performed by "do-it-yourselfers." Customers should not assume this bulletin applies to their vehicle or that their vehicle will develop the described concern. To determine if the information applies, customers should contact their nearest authorized Mazda dealership. Mazda North American Operations reserves the right to alter the specifications and contents of this bulletin without obligation or advance notice. All rights reserved. No part of this bulletin may be reproduced in any form or by any means, electronic or mechanical---including photocopying and recording and the use of any kind of information storage and retrieval system ---without permission in writing.

6. Disconnect the CABLE-MODULE [W].

a. Lower the cover [W].

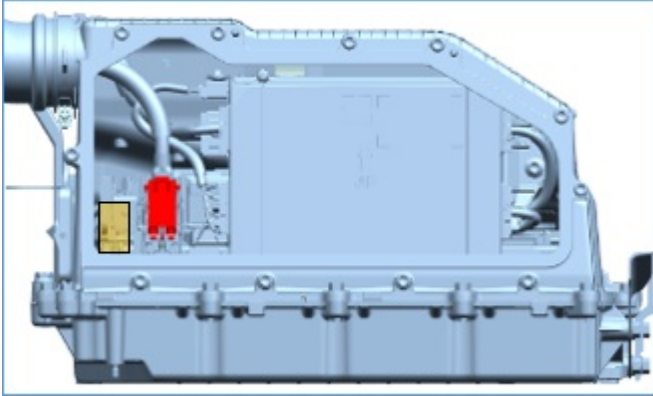

b. Remove the nut [W].

Tightening torque when installing: 8.0 ± 1.1 ft·lb (10.8 ± 1.5 N·m)

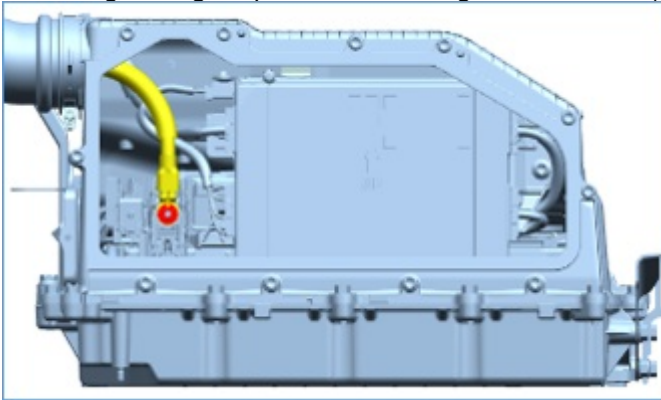

c. Apply insulating tape [W].

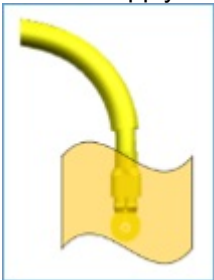

CONSUMER NOTICE: The information and instructions in this bulletin are intended for use by skilled technicians. Mazda technicians utilize the proper tools/ equipment and take training to correctly and safely maintain Mazda vehicles. These instructions should not be performed by "do-it-yourselfers." Customers should not assume this bulletin applies to their vehicle or that their vehicle will develop the described concern. To determine if the information applies, customers should contact their nearest authorized Mazda dealership. Mazda North American Operations reserves the right to alter the specifications and contents of this bulletin without obligation or advance notice. All rights reserved. No part of this bulletin may be reproduced in any form or by any means, electronic or mechanical---including photocopying and recording and the use of any kind of information storage and retrieval system ---without permission in writing.

d. Close the cover and apply insulating tape [N]

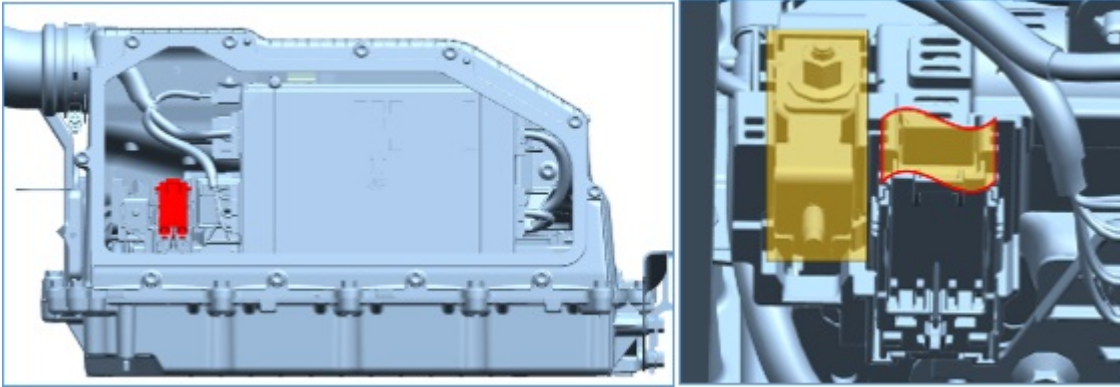

e. Disconnect the connectors and apply insulating tape [N]

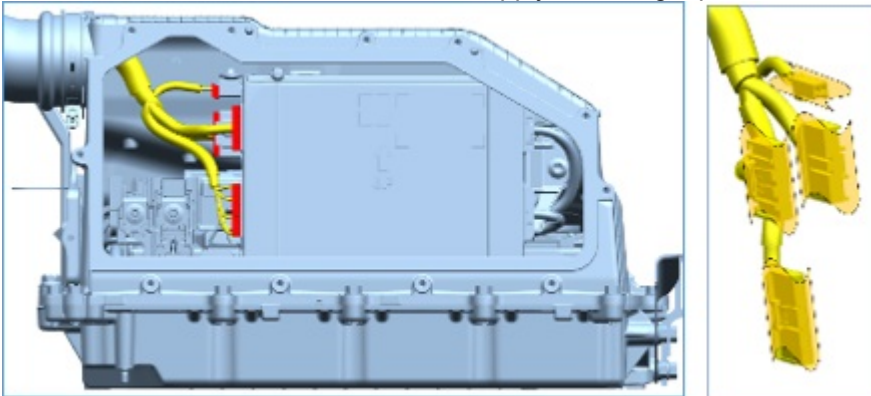

7. Remove COVER HOSE [N]

a. Loosen the hose clamps.

Tightening torque when installing: 2.2 ± 0.4 ft·lb (3.0 ± 0.5 N·m)

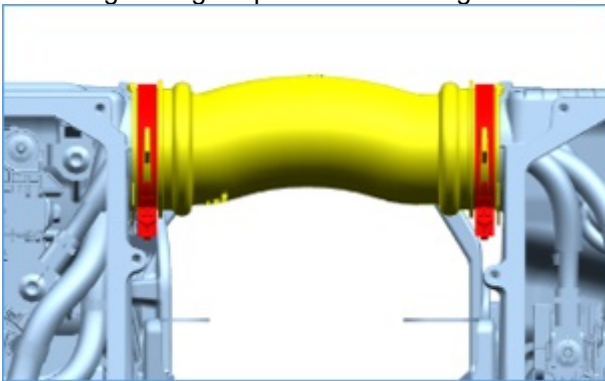

CONSUMER NOTICE: The information and instructions in this bulletin are intended for use by skilled technicians. Mazda technicians utilize the proper tools/ equipment and take training to correctly and safely maintain Mazda vehicles. These instructions should not be performed by "do-it-yourselfers." Customers should not assume this bulletin applies to their vehicle or that their vehicle will develop the described concern. To determine if the information applies, customers should contact their nearest authorized Mazda dealership. Mazda North American Operations reserves the right to alter the specifications and contents of this bulletin without obligation or advance notice. All rights reserved. No part of this bulletin may be reproduced in any form or by any means, electronic or mechanical---including photocopying and recording and the use of any kind of information storage and retrieval system ---without permission in writing.

8. Remove the BRKT-BAT.

a. Remove the bolts.

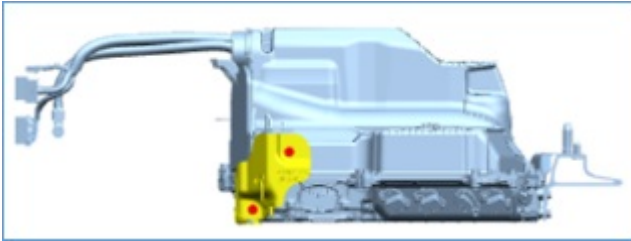
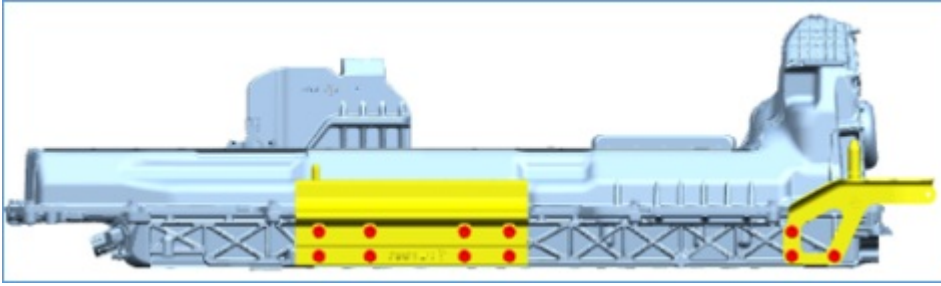
Tightening torque when installing: 6.8 ± 1.1 ft·lb (9.3 ± 1.5 N·m)

b. Remove the bolts.

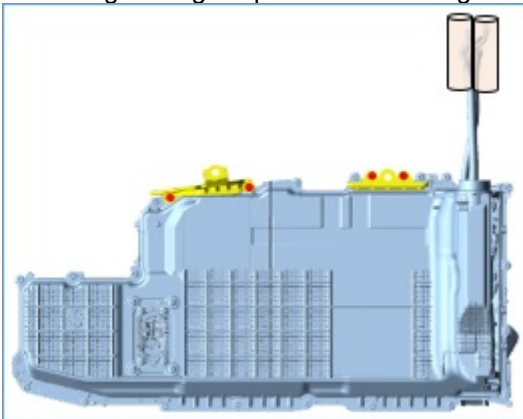
Tightening torque when installing: 19.2 ± 3.2 ft·lb (26.0 ± 4.4 N·m)

CONSUMER NOTICE: The information and instructions in this bulletin are intended for use by skilled technicians. Mazda technicians utilize the proper tools/ equipment and take training to correctly and safely maintain Mazda vehicles. These instructions should not be performed by "do-it-yourselfers." Customers should not assume this bulletin applies to their vehicle or that their vehicle will develop the described concern. To determine if the information applies, customers should contact their nearest authorized Mazda dealership. Mazda North American Operations reserves the right to alter the specifications and contents of this bulletin without obligation or advance notice. All rights reserved. No part of this bulletin may be reproduced in any form or by any means, electronic or mechanical---including photocopying and recording and the use of any kind of information storage and retrieval system ---without permission in writing.

9. Remove the COVER ASSY-BAT.

a. Remove the bolts.

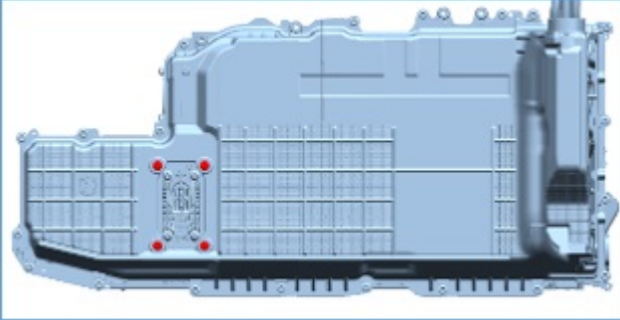
Tightening torque when installing: 8.0 ± 1.1 ft·lb (10.8 ± 1.5 N·m)

b. Remove the bolts [W].

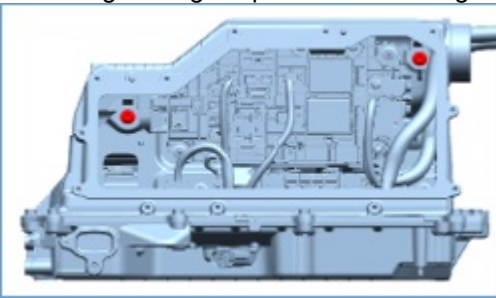
Tightening torque when installing: 6.8 ± 1.1 ft·lb (9.3 ± 1.5 N·m)

c. Remove the bolts.

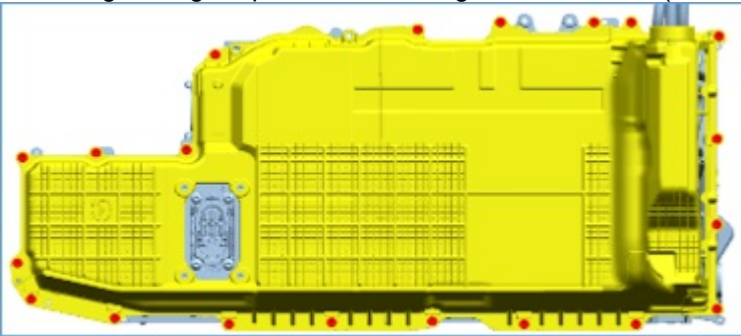
Tightening torque when installing: 19.2 ± 3.2 ft·lb (26.0 ± 4.4 N·m)

10. With an assistant, remove the upper cover.

CONSUMER NOTICE: The information and instructions in this bulletin are intended for use by skilled technicians. Mazda technicians utilize the proper tools/ equipment and take training to correctly and safely maintain Mazda vehicles. These instructions should not be performed by "do-it-yourselfers." Customers should not assume this bulletin applies to their vehicle or that their vehicle will develop the described concern. To determine if the information applies, customers should contact their nearest authorized Mazda dealership. Mazda North American Operations reserves the right to alter the specifications and contents of this bulletin without obligation or advance notice. All rights reserved. No part of this bulletin may be reproduced in any form or by any means, electronic or mechanical---including photocopying and recording and the use of any kind of information storage and retrieval system ---without permission in writing.

11. Cover it with an insulating mat.

WARNING: The insulating mat must always cover parts other than the parts to be worked on.

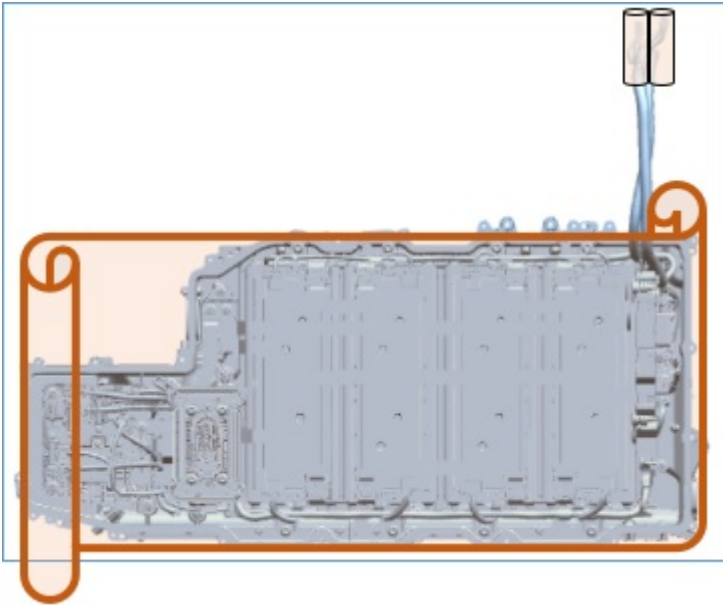

COVER ASSY-BAT LEFT SIDE MOUNTING

1. Install it in reverse to the removal procedure [↗].

NOTE:

- For the COVER ASSY-BAT, PLATE ASSY, replace the GASKET before installation.
- Check that there are no foreign objects in the gasket grooves.
- Insert the convex part of the gasket into the recess of COVER ASSY-BAT and insert it along the groove.
- When assembling, it must be turned upside down and not assembled.

COVER ASSY-BAT

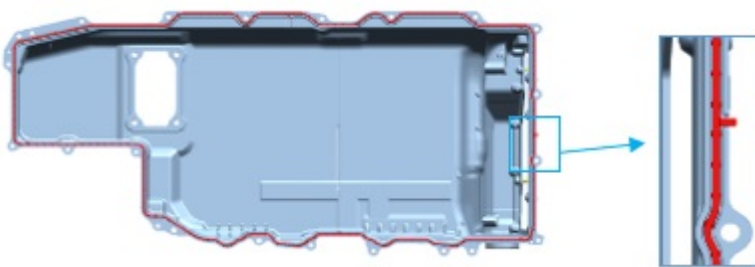

CONSUMER NOTICE: The information and instructions in this bulletin are intended for use by skilled technicians. Mazda technicians utilize the proper tools/ equipment and take training to correctly and safely maintain Mazda vehicles. These instructions should not be performed by "do-it-yourselfers." Customers should not assume this bulletin applies to their vehicle or that their vehicle will develop the described concern. To determine if the information applies, customers should contact their nearest authorized Mazda dealership. Mazda North American Operations reserves the right to alter the specifications and contents of this bulletin without obligation or advance notice. All rights reserved. No part of this bulletin may be reproduced in any form or by any means, electronic or mechanical---including photocopying and recording and the use of any kind of information storage and retrieval system ---without permission in writing.

PLATE ASSY

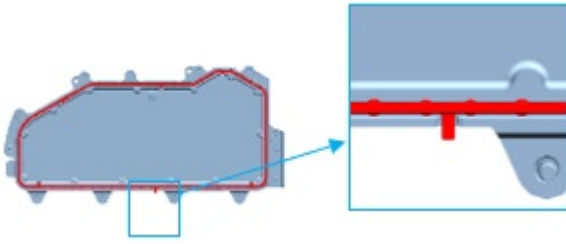
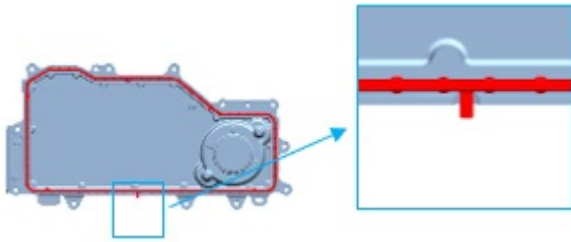
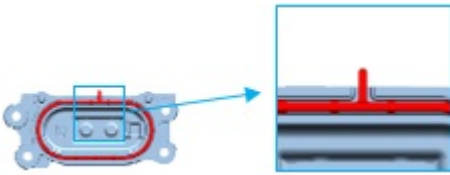

PLATE ASSY



COVER ASSY-BAT



CONSUMER NOTICE: The information and instructions in this bulletin are intended for use by skilled technicians. Mazda technicians utilize the proper tools/ equipment and take training to correctly and safely maintain Mazda vehicles. These instructions should not be performed by "do-it-yourselfers." Customers should not assume this bulletin applies to their vehicle or that their vehicle will develop the described concern. To determine if the information applies, customers should contact their nearest authorized Mazda dealership. Mazda North American Operations reserves the right to alter the specifications and contents of this bulletin without obligation or advance notice. All rights reserved. No part of this bulletin may be reproduced in any form or by any means, electronic or mechanical---including photocopying and recording and the use of any kind of information storage and retrieval system ---without permission in writing.

Follow the steps below to install the bolts.

a. Install and tighten the bolts in the following order: b1 - b20, b21, b22.

Tightening torque when installing: 19.2 ± 3.2 ft·lb (26.0 ± 4.4 N·m)

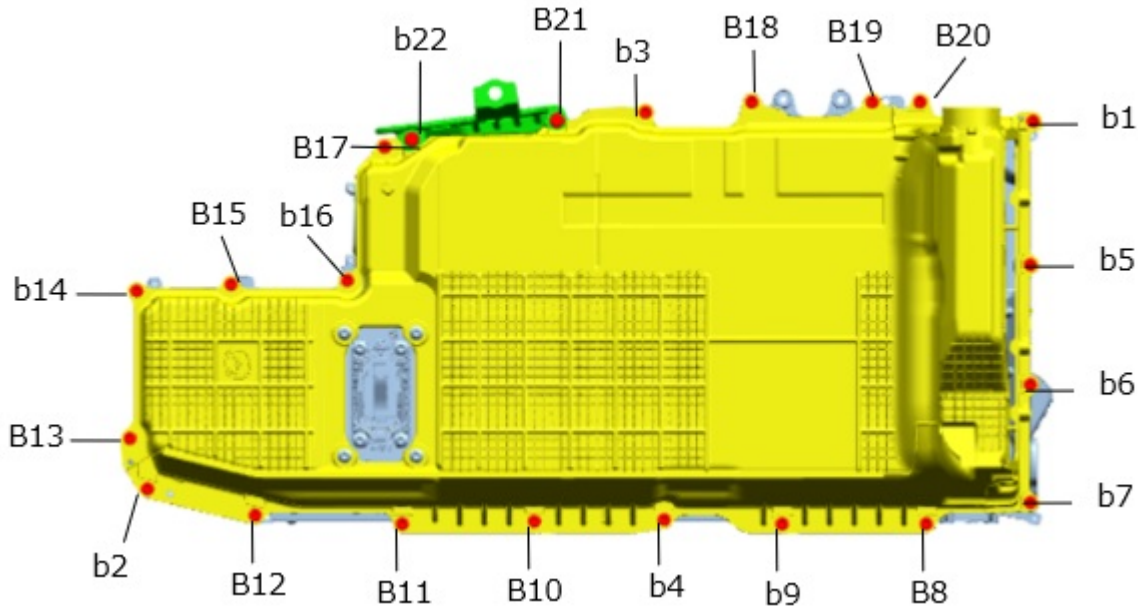

b. Retighten in order of b1 to b22.

c. Install the remaining bolts (in no particular order).

NOTE: Install the COVER HOSE.

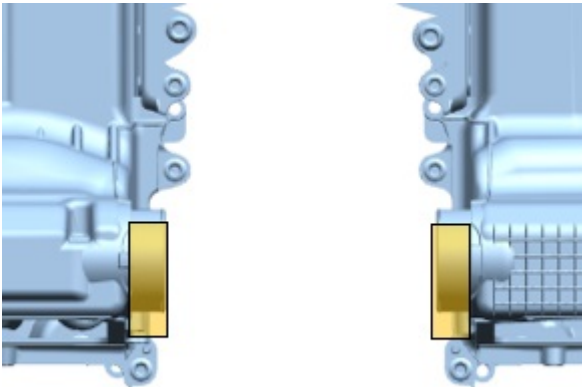

CONSUMER NOTICE: The information and instructions in this bulletin are intended for use by skilled technicians. Mazda technicians utilize the proper tools/ equipment and take training to correctly and safely maintain Mazda vehicles. These instructions should not be performed by "do-it-yourselfers." Customers should not assume this bulletin applies to their vehicle or that their vehicle will develop the described concern. To determine if the information applies, customers should contact their nearest authorized Mazda dealership. Mazda North American Operations reserves the right to alter the specifications and contents of this bulletin without obligation or advance notice. All rights reserved. No part of this bulletin may be reproduced in any form or by any means, electronic or mechanical---including photocopying and recording and the use of any kind of information storage and retrieval system ---without permission in writing.

2. Perform an airtightness check.
 - a. Install SST (49JP-046A0).
 - b. Item 3 (GAGE SET) requires using two existing bolts from the battery
- Tightening torque when installing: 8.0 ± 1.1 ft·lb (10.8 ± 1.5 N·m)

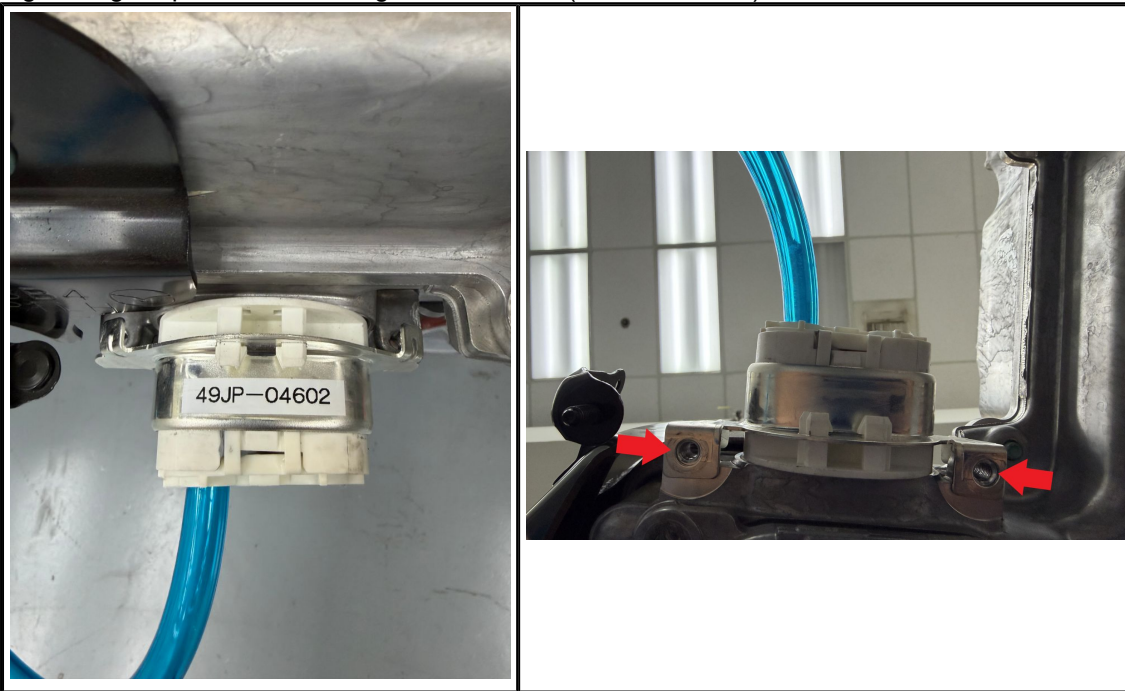

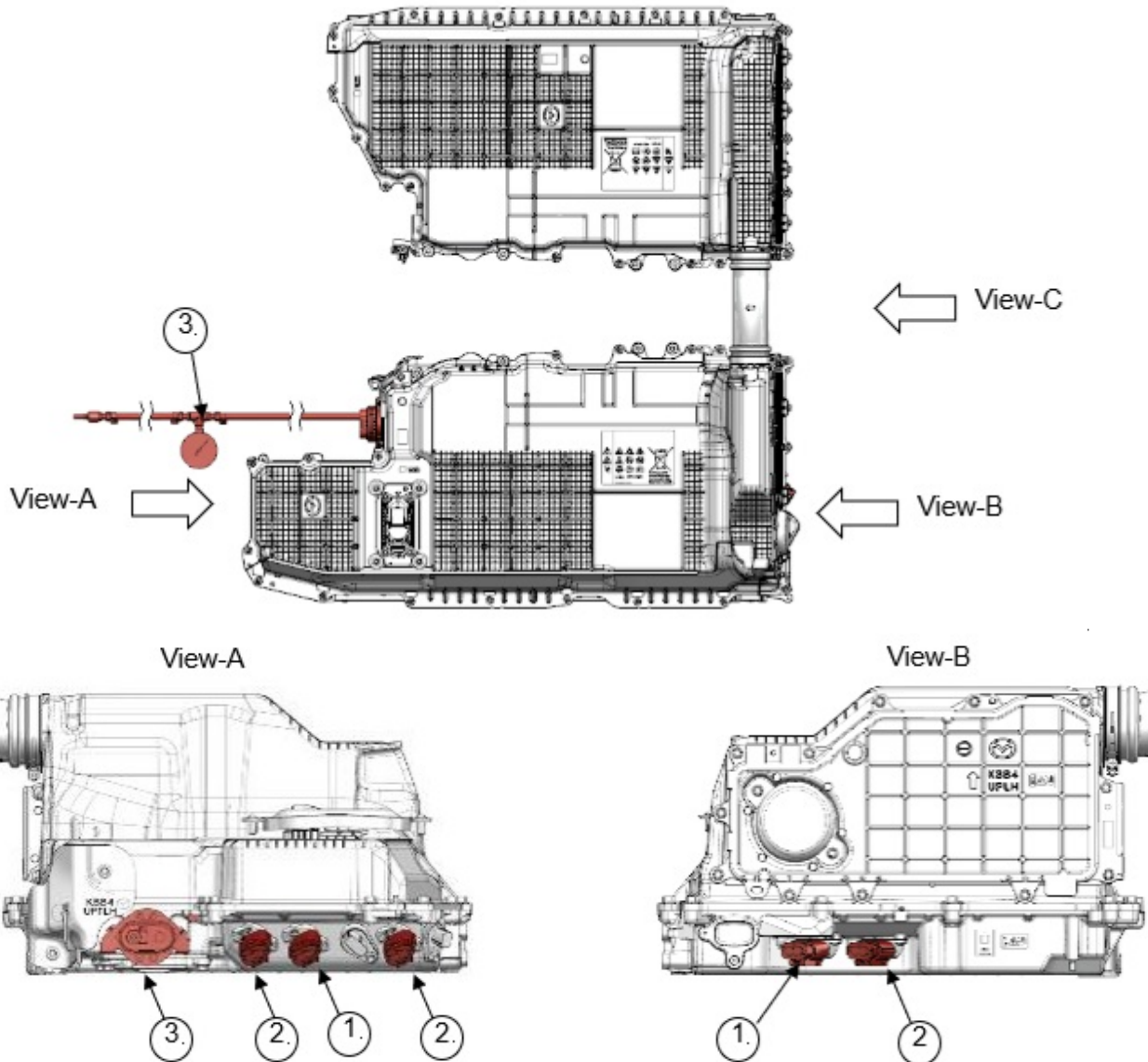

CONSUMER NOTICE: The information and instructions in this bulletin are intended for use by skilled technicians. Mazda technicians utilize the proper tools/ equipment and take training to correctly and safely maintain Mazda vehicles. These instructions should not be performed by "do-it-yourselfers." Customers should not assume this bulletin applies to their vehicle or that their vehicle will develop the described concern. To determine if the information applies, customers should contact their nearest authorized Mazda dealership. Mazda North American Operations reserves the right to alter the specifications and contents of this bulletin without obligation or advance notice. All rights reserved. No part of this bulletin may be reproduced in any form or by any means, electronic or mechanical---including photocopying and recording and the use of any kind of information storage and retrieval system ---without permission in writing.



CONSUMER NOTICE: The information and instructions in this bulletin are intended for use by skilled technicians. Mazda technicians utilize the proper tools/ equipment and take training to correctly and safely maintain Mazda vehicles. These instructions should not be performed by "do-it-yourselfers." Customers should not assume this bulletin applies to their vehicle or that their vehicle will develop the described concern. To determine if the information applies, customers should contact their nearest authorized Mazda dealership. Mazda North American Operations reserves the right to alter the specifications and contents of this bulletin without obligation or advance notice. All rights reserved. No part of this bulletin may be reproduced in any form or by any means, electronic or mechanical--including photocopying and recording and the use of any kind of information storage and retrieval system ---without permission in writing.

49JP-046A0 LIB_AIR_TIGHT_TESTER_PHEV-2

No.	IMAGE	NAME
(1)		COUPLER A
(2)		COUPLER B
(3)		GAGE SET

View-C



b. Apply tape to prevent air from escaping (6)(7). On the red circle of the part, making sure it adheres properly (Recommended: 3M 243J Plus 30mm or equivalent).

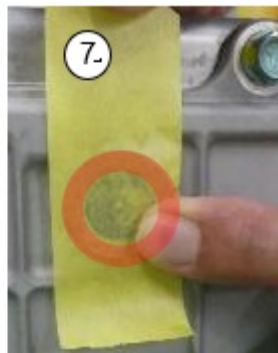
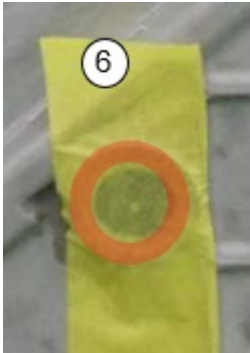

CONSUMER NOTICE: The information and instructions in this bulletin are intended for use by skilled technicians. Mazda technicians utilize the proper tools/ equipment and take training to correctly and safely maintain Mazda vehicles. These instructions should not be performed by "do-it-yourselfers." Customers should not assume this bulletin applies to their vehicle or that their vehicle will develop the described concern. To determine if the information applies, customers should contact their nearest authorized Mazda dealership. Mazda North American Operations reserves the right to alter the specifications and contents of this bulletin without obligation or advance notice. All rights reserved. No part of this bulletin may be reproduced in any form or by any means, electronic or mechanical---including photocopying and recording and the use of any kind of information storage and retrieval system ---without permission in writing.

c. Install the terminal cover and torque the bolts to specification, then install the service plug last for safety.

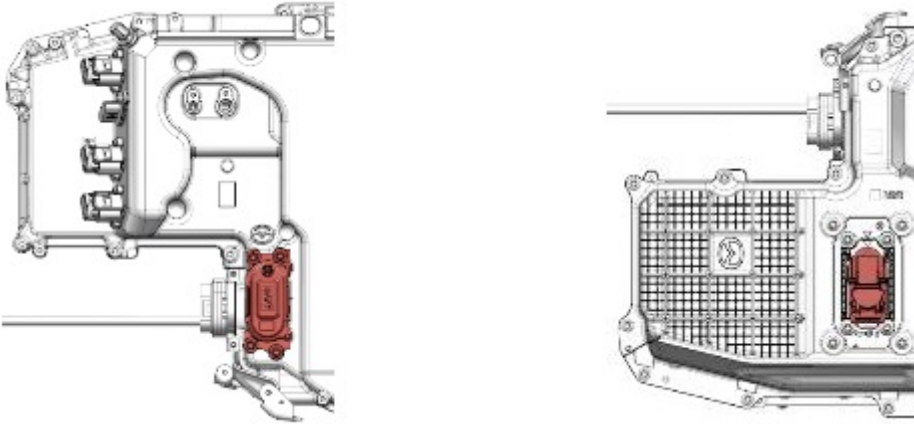

3. Install the COVER ASSY-BAT.

Follow the steps below to install the bolts.

a. Install the bolts in the following order:

- a → b → c → d (or a → b → d → c)

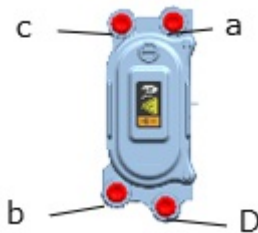

b. Tighten the bolts in the order of step a.

Tightening torque when installing: 8.0 ± 1.1 ft·lb (10.8 ± 1.5 N·m)

c. Connect the air pump to the SST and inject air of 0.29 psi (2.0kPa).

ATTENTION:

(1) DO NOT use compressor air from service shops as SST and driving batteries may be damaged.

(2) Using a hand pump, slowly pump air into the battery. You MUST take at least 2 minutes to reach 0.30 ro 0.31 psi (2.1 to 2.2 Kpa). Rapid injection will lead to damage to the gauge.

(3) For VENT-GAS ASSY ((8) in VIEW C above), DO NOT inject air over 0.4 psi (3.0 Kpa) because there is a risk that the valve will open.

- If the valve is opened, replace VENT-GAS ASSY or PLATE ASSY because reuse is not possible when the valve is opened.

CONSUMER NOTICE: The information and instructions in this bulletin are intended for use by skilled technicians. Mazda technicians utilize the proper tools/ equipment and take training to correctly and safely maintain Mazda vehicles. These instructions should not be performed by "do-it-yourselfers." Customers should not assume this bulletin applies to their vehicle or that their vehicle will develop the described concern. To determine if the information applies, customers should contact their nearest authorized Mazda dealership. Mazda North American Operations reserves the right to alter the specifications and contents of this bulletin without obligation or advance notice. All rights reserved. No part of this bulletin may be reproduced in any form or by any means, electronic or mechanical---including photocopying and recording and the use of any kind of information storage and retrieval system ---without permission in writing.

(4) Disconnect the air pump from the SST.

- If the SST and the air pump are connected, there is a risk that air will leak from the connection

(5) Adjust by pressing the valve so that it is 0.29 psi (2.0kPa).

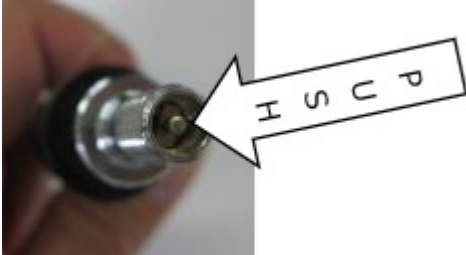

c. Do an airtightness check.

After setting the internal pressure to 0.29 psi (2.0kPa), the gauge must maintain at least 0.28 psi (1.9 kPa) for 1 minute.

- If 0.28 psi (1.9 kPa) or more cannot be maintained, check the following:
 - 1) Check the SST installation status.
 - 2) Check the condition of gaskets set as non-reusable parts.
 - 3) Check if COVER ASSY-BAT is damaged.

d. Remove the SST in reverse order to the installation procedure.



CONSUMER NOTICE: The information and instructions in this bulletin are intended for use by skilled technicians. Mazda technicians utilize the proper tools/ equipment and take training to correctly and safely maintain Mazda vehicles. These instructions should not be performed by "do-it-yourselfers." Customers should not assume this bulletin applies to their vehicle or that their vehicle will develop the described concern. To determine if the information applies, customers should contact their nearest authorized Mazda dealership. Mazda North American Operations reserves the right to alter the specifications and contents of this bulletin without obligation or advance notice. All rights reserved. No part of this bulletin may be reproduced in any form or by any means, electronic or mechanical---including photocopying and recording and the use of any kind of information storage and retrieval system ---without permission in writing.

PLUG ASSY-SERVICE REMOVAL

WARNING: If the following sign  is indicated in the procedure, high-voltage components (live parts with over 50V) are involved. Make sure to take the necessary actions before servicing an electric vehicle, or you may get an electric shock that can result in a serious injury or death in the worst case. Before servicing the electric vehicle, refer to the (HIGH-VOLTAGE SERVICE CAUTIONS) in MGSS and make sure to take all necessary actions to start services This repair can **only** be performed by properly trained technicians.

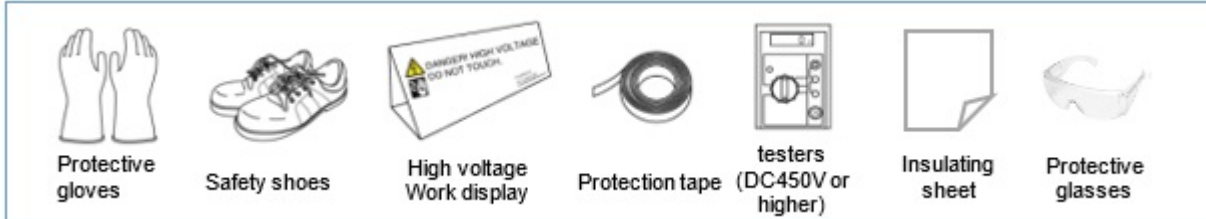
Items to be prepared



Target parts	Location (red part)
	

[Non-reusable parts]

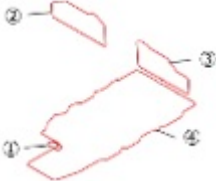
Part number	Location (red part)
(1) KBB4-302K5 (2) KBB3-302K3 (3) KBB4-302K3 (4) KBB4-302K2	

NOTE: When performing the procedure below, use **only** hand tools and calibrated torque wrenches for all internal work and reassembly operations.

1. Remove the COVER ASSY-BAT . See: COVER ASSY-BAT left side.

CONSUMER NOTICE: The information and instructions in this bulletin are intended for use by skilled technicians. Mazda technicians utilize the proper tools/ equipment and take training to correctly and safely maintain Mazda vehicles. These instructions should not be performed by "do-it-yourselfers." Customers should not assume this bulletin applies to their vehicle or that their vehicle will develop the described concern. To determine if the information applies, customers should contact their nearest authorized Mazda dealership. Mazda North American Operations reserves the right to alter the specifications and contents of this bulletin without obligation or advance notice. All rights reserved. No part of this bulletin may be reproduced in any form or by any means, electronic or mechanical--including photocopying and recording and the use of any kind of information storage and retrieval system ---without permission in writing.

2. Check the coverage area of the insulating mat .

WARNING: The insulating mat must always cover parts other than the parts to be worked on.

*Red: parts to be worked on.

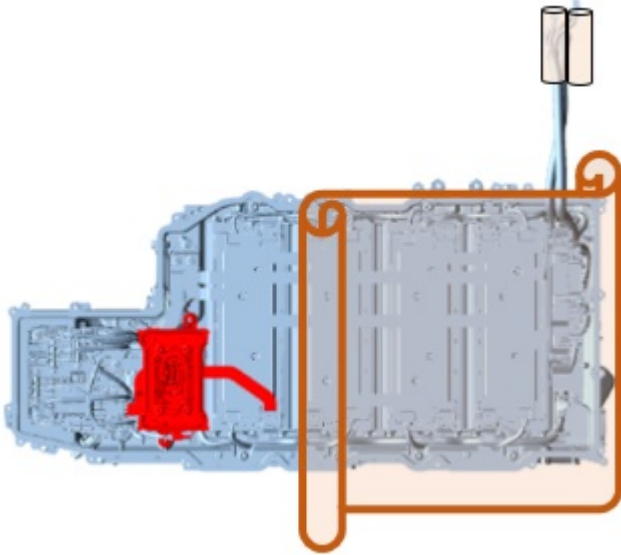

3. Remove the PLUG ASSY-SERVICE .

a. Remove the connector.

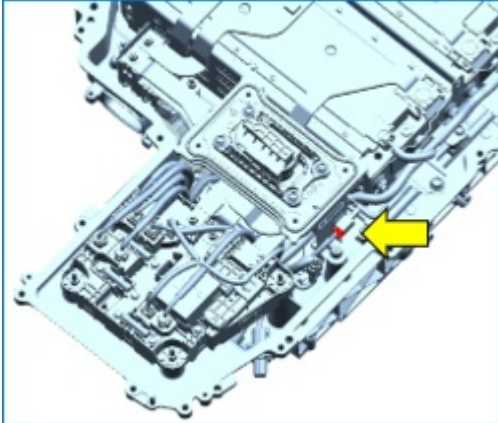

CONSUMER NOTICE: The information and instructions in this bulletin are intended for use by skilled technicians. Mazda technicians utilize the proper tools/ equipment and take training to correctly and safely maintain Mazda vehicles. These instructions should not be performed by "do-it-yourselfers." Customers should not assume this bulletin applies to their vehicle or that their vehicle will develop the described concern. To determine if the information applies, customers should contact their nearest authorized Mazda dealership. Mazda North American Operations reserves the right to alter the specifications and contents of this bulletin without obligation or advance notice. All rights reserved. No part of this bulletin may be reproduced in any form or by any means, electronic or mechanical---including photocopying and recording and the use of any kind of information storage and retrieval system ---without permission in writing.

b. Open the cover 

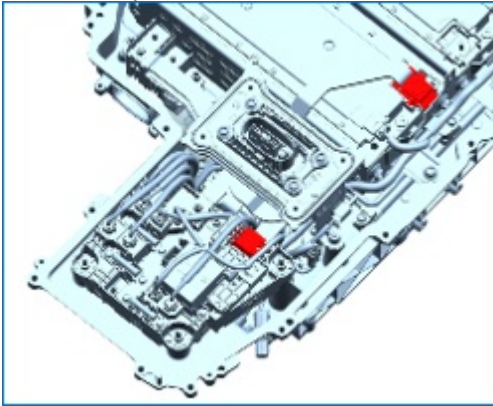

c. Remove the nuts ,
Tightening torque when installing: 6.8 ± 1.1 ft·lb (9.3 ± 1.5 N·m)

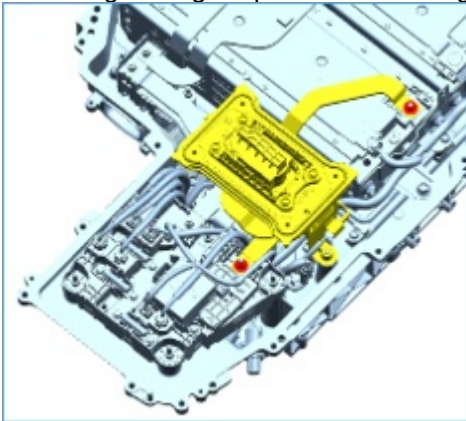

PLUG ASSY-SERVICE INSTALLATION

1. Install it in reverse to the removal procedure 

CONSUMER NOTICE: The information and instructions in this bulletin are intended for use by skilled technicians. Mazda technicians utilize the proper tools/ equipment and take training to correctly and safely maintain Mazda vehicles. These instructions should not be performed by "do-it-yourselfers." Customers should not assume this bulletin applies to their vehicle or that their vehicle will develop the described concern. To determine if the information applies, customers should contact their nearest authorized Mazda dealership. Mazda North American Operations reserves the right to alter the specifications and contents of this bulletin without obligation or advance notice. All rights reserved. No part of this bulletin may be reproduced in any form or by any means, electronic or mechanical---including photocopying and recording and the use of any kind of information storage and retrieval system ---without permission in writing.

PARTS INFORMATION

Parts Number	Description	Qty.	Notes
KR9P-61-4C0B	Compr, Eec-Drvn	1	Updated compressor is "B" level or greater.
KBB4-30-2J0	Box, Junction	1	
0000-KT-PHEV	PHEV Battery Removal Replacement Parts Kit	1	Kit includes: 999461000 (4 Nuts), PE2340305 (2 Gaskets), GJ6E61J19 (1 O-ring No. 2), MH01302W3 (2 O-rings), and BBM461J17 (1 O-ring Cooling unit).
0000-AC-FUSE	AC Fuse Replacement Parts Kit	1	Kit includes: KBB4302K5 (1 Gasket), KBB3302K3 (1 Gasket), KBB4302K3 (1 Gasket), KBB4302K8 (1 Gasket), KBB4302K2 (1 Gasket)

NOTE: MASH authorization is required for all parts replacement except A/C compressor. Review Mazda Warranty Policies and Procedures Policy No.:3.28 for details.

CONSUMER NOTICE: The information and instructions in this bulletin are intended for use by skilled technicians. Mazda technicians utilize the proper tools/ equipment and take training to correctly and safely maintain Mazda vehicles. These instructions should not be performed by "do-it-yourselfers." Customers should not assume this bulletin applies to their vehicle or that their vehicle will develop the described concern. To determine if the information applies, customers should contact their nearest authorized Mazda dealership. Mazda North American Operations reserves the right to alter the specifications and contents of this bulletin without obligation or advance notice. All rights reserved. No part of this bulletin may be reproduced in any form or by any means, electronic or mechanical---including photocopying and recording and the use of any kind of information storage and retrieval system ---without permission in writing.

WARRANTY INFORMATION**NOTE:**

- This warranty information applies only to verified customer complaints on vehicles eligible for warranty repair.
- This repair will be covered under Mazda's New Vehicle Limited Warranty term, California Emission Warranty (Long term) or Transitional Zero Emission Vehicle Warranty (2024-2025 MY).
- Additional diagnostic time cannot be claimed for this repair.
- This repair can only be performed by properly trained technicians.

Warranty Type	A
Symptom Code	59
Damage Code	9W
Part Number Main Cause	KR9P-61-4C0B
Quantity	1
Operation Number / Labor Hours:	XXX6TARX / 0.9 Hrs (Replace compressor) XXX6TBRX / 3.8 Hrs (Replace compressor and junction box)

NOTE:

- For **compressor replacement**, submit a second claim for AC evacuation and recharge. Make sure recovery and refill printout is attached to the claim.
- For **compressor and junction box replacement**, submit a second claim using the high voltage battery as PNMC, QTY 0, Labor R&R, plus AC evacuation and recharge. Make sure recovery and refill printout is attached to the claim.

CONSUMER NOTICE: The information and instructions in this bulletin are intended for use by skilled technicians. Mazda technicians utilize the proper tools/ equipment and take training to correctly and safely maintain Mazda vehicles. These instructions should not be performed by "do-it-yourselfers." Customers should not assume this bulletin applies to their vehicle or that their vehicle will develop the described concern. To determine if the information applies, customers should contact their nearest authorized Mazda dealership. Mazda North American Operations reserves the right to alter the specifications and contents of this bulletin without obligation or advance notice. All rights reserved. No part of this bulletin may be reproduced in any form or by any means, electronic or mechanical---including photocopying and recording and the use of any kind of information storage and retrieval system ---without permission in writing.