

# Technical Service Bulletin

Mazda North American Operations  
Irvine, CA 92618-2922



<b>Subject:</b>  <b>VIBRATION AND ABNORMAL NOISE UNDER-FOOT NOISE DURING SHARP LEFT-TURN ACCELERATION</b>	<b>Bulletin No.: 01-002/26</b>
	<b>Last Issued : 06/11/2026</b>

## BULLETIN NOTES

This bulletin supersedes the previously issued bulletin(s) listed below. The changes are noted in Red.

Previous TSBs:	Date(s) Issued:
01-002/26	01/07/26
01-007/25	11/14/25

## APPLICABLE MODEL(S)/VINS

2024-2026 CX-90 (All) with VINS lower than JM3KK\*\*\*\*\*353975 (produced before September 11, 2025)

2025-2026 CX-70 (All) with VINS lower than JM3KJ\*\*\*\*\*200374 (produced before September 11, 2025)

## DESCRIPTION

Some vehicles may exhibit a vibration in the accelerator pedal and steering wheel when accelerating during a sharp left-hand turn. An abnormal noise may also be heard from the footwell area. This may be caused by insufficient clearance between the engine mount stopper rubber and the engine mount bracket.

Customer may state:

- Vehicle **shudders/vibrates on left turns**, most often when accelerating from a stop or entering a driveway.
- They feel a **pop or grind** in the accelerator pedal when the vibration occurs.
- They hear a **rumbling or grinding noise**, mainly from the **right side**, during the left-turn shudder.

**NOTE:** The condition does not occur at shallow steering angles or when the vehicle is stationary and the steering effort remains unchanged when the vibration and noise are present.

Customers having this concern should have their vehicle repaired using the following repair procedure.

## REPAIR PROCEDURE

1. Verify the customer concern.

**NOTE: DO NOT use power tools in this procedure. Use hand tools only.**

2. Disconnect the negative battery terminal using the procedure in [NEGATIVE BATTERY TERMINAL DISCONNECTION/CONNECTION].

3. Remove the engine cover.

**CONSUMER NOTICE:** The information and instructions in this bulletin are intended for use by skilled technicians. Mazda technicians utilize the proper tools/ equipment and take training to correctly and safely maintain Mazda vehicles. These instructions should not be performed by "do-it-yourselfers." Customers should not assume this bulletin applies to their vehicle or that their vehicle will develop the described concern. To determine if the information applies, customers should contact their nearest authorized Mazda dealership. Mazda North American Operations reserves the right to alter the specifications and contents of this bulletin without obligation or advance notice. All rights reserved. No part of this bulletin may be reproduced in any form or by any means, electronic or mechanical--including photocopying and recording and the use of any kind of information storage and retrieval system ---without permission in writing.

## 4. Remove the heat insulator.

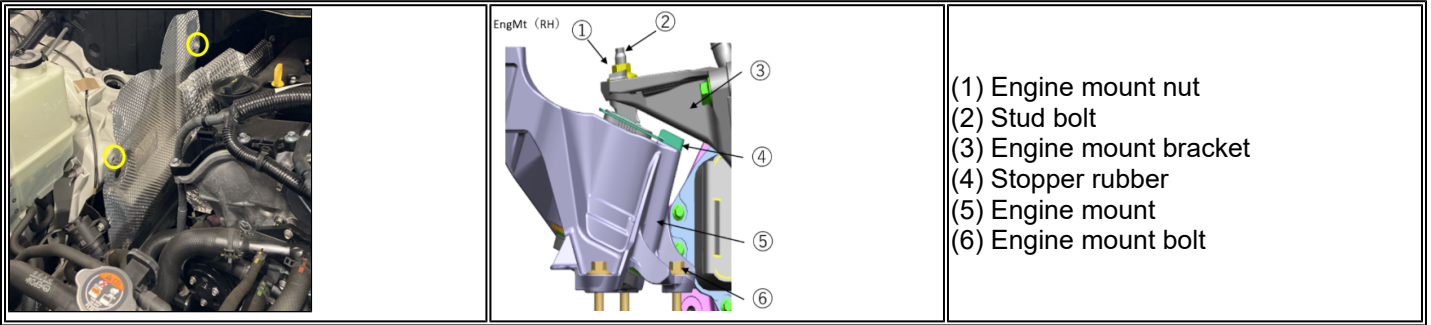

5. Remove the right front (RF) tire using the procedure in [FRONT UNDER COVER REMOVAL/INSTALLATION].

6. Remove the front under covers (splash shields) No.1, No.2, and No.3 using the steps in [FRONT UNDER COVER REMOVAL/INSTALLATION].

7. Remove the mudguard bolt and fastener.

8. Remove the right-side (passenger side) front splash shield No.2 using the procedure in [FRONT UNDER COVER REMOVAL/INSTALLATION].

9. Remove the nut (left image (1)) from the engine mount (left image (3)) and loosen but DO NOT remove the engine mount bolts (left image (2), right image (1)).

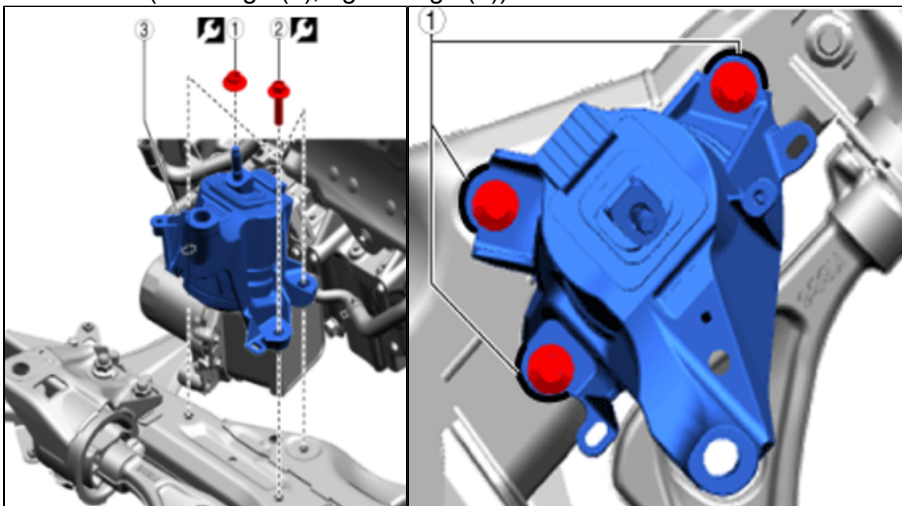

**CONSUMER NOTICE:** The information and instructions in this bulletin are intended for use by skilled technicians. Mazda technicians utilize the proper tools/ equipment and take training to correctly and safely maintain Mazda vehicles. These instructions should not be performed by "do-it-yourselfers." Customers should not assume this bulletin applies to their vehicle or that their vehicle will develop the described concern. To determine if the information applies, customers should contact their nearest authorized Mazda dealership. Mazda North American Operations reserves the right to alter the specifications and contents of this bulletin without obligation or advance notice. All rights reserved. No part of this bulletin may be reproduced in any form or by any means, electronic or mechanical---including photocopying and recording and the use of any kind of information storage and retrieval system ---without permission in writing.

**NOTE:** The engine mount bolts are easily accessed with a 36-inch (90 cm) extension from above. A 1/2 inch drive is recommended because it flexes less.



10. Remove the engine mount stud.

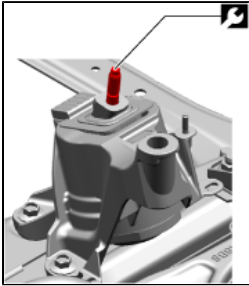

**CONSUMER NOTICE:** The information and instructions in this bulletin are intended for use by skilled technicians. Mazda technicians utilize the proper tools/ equipment and take training to correctly and safely maintain Mazda vehicles. These instructions should not be performed by "do-it-yourselfers." Customers should not assume this bulletin applies to their vehicle or that their vehicle will develop the described concern. To determine if the information applies, customers should contact their nearest authorized Mazda dealership. Mazda North American Operations reserves the right to alter the specifications and contents of this bulletin without obligation or advance notice. All rights reserved. No part of this bulletin may be reproduced in any form or by any means, electronic or mechanical---including photocopying and recording and the use of any kind of information storage and retrieval system ---without permission in writing.

11. Support the engine with a jack, but DO NOT lift. A screw jack is recommended as it is more precise with lifting and lowering. **NOTE:** When jacking up the oil pan, insert a cushioning material between the jack and the pan (e.g., a large wooden block that extends beyond the oil pan and protects it).



**NOTE:** If using a transmission jack, make sure it does not interfere with the crossmember.

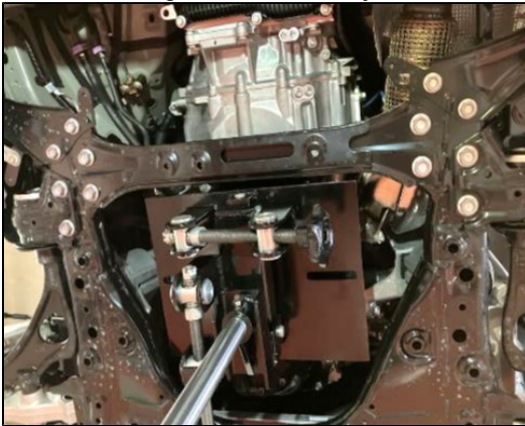

12. Insert the cushioning material between the jack and the oil pan.

13. Loosen, but DO NOT remove the three right-side member bracket (subframe) bolts (1).

14. Loosen, but DO NOT remove the two crossmember bolts (2).

15. Remove the bolt that holds the heater hose bracket (3) to the right engine mount.

**NOTE:** The outer bolts (circled yellow (2)) are for crossmember (subframe) bolts. The center bolt between these 2 is the bolt that goes through the engine mount (when looking straight up at the A-arm). The hole through the A-arm bracket is where a tool extension goes through to remove the bolt for the mount. This is the bolt in step 2 below (yellow circle).

**CONSUMER NOTICE:** The information and instructions in this bulletin are intended for use by skilled technicians. Mazda technicians utilize the proper tools/ equipment and take training to correctly and safely maintain Mazda vehicles. These instructions should not be performed by "do-it-yourselfers." Customers should not assume this bulletin applies to their vehicle or that their vehicle will develop the described concern. To determine if the information applies, customers should contact their nearest authorized Mazda dealership. Mazda North American Operations reserves the right to alter the specifications and contents of this bulletin without obligation or advance notice. All rights reserved. No part of this bulletin may be reproduced in any form or by any means, electronic or mechanical---including photocopying and recording and the use of any kind of information storage and retrieval system ---without permission in writing.

View from underside (right side).

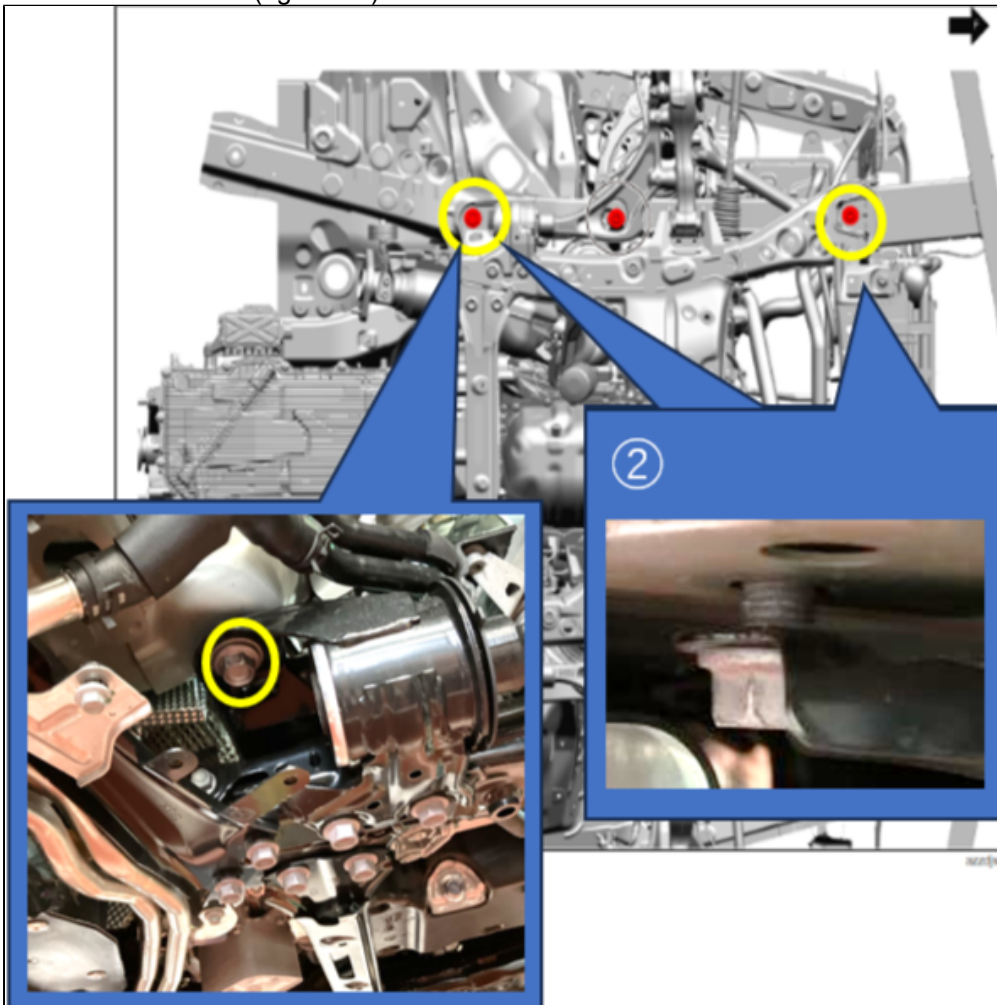

**CONSUMER NOTICE:** The information and instructions in this bulletin are intended for use by skilled technicians. Mazda technicians utilize the proper tools/ equipment and take training to correctly and safely maintain Mazda vehicles. These instructions should not be performed by "do-it-yourselfers." Customers should not assume this bulletin applies to their vehicle or that their vehicle will develop the described concern. To determine if the information applies, customers should contact their nearest authorized Mazda dealership. Mazda North American Operations reserves the right to alter the specifications and contents of this bulletin without obligation or advance notice. All rights reserved. No part of this bulletin may be reproduced in any form or by any means, electronic or mechanical---including photocopying and recording and the use of any kind of information storage and retrieval system ---without permission in writing.

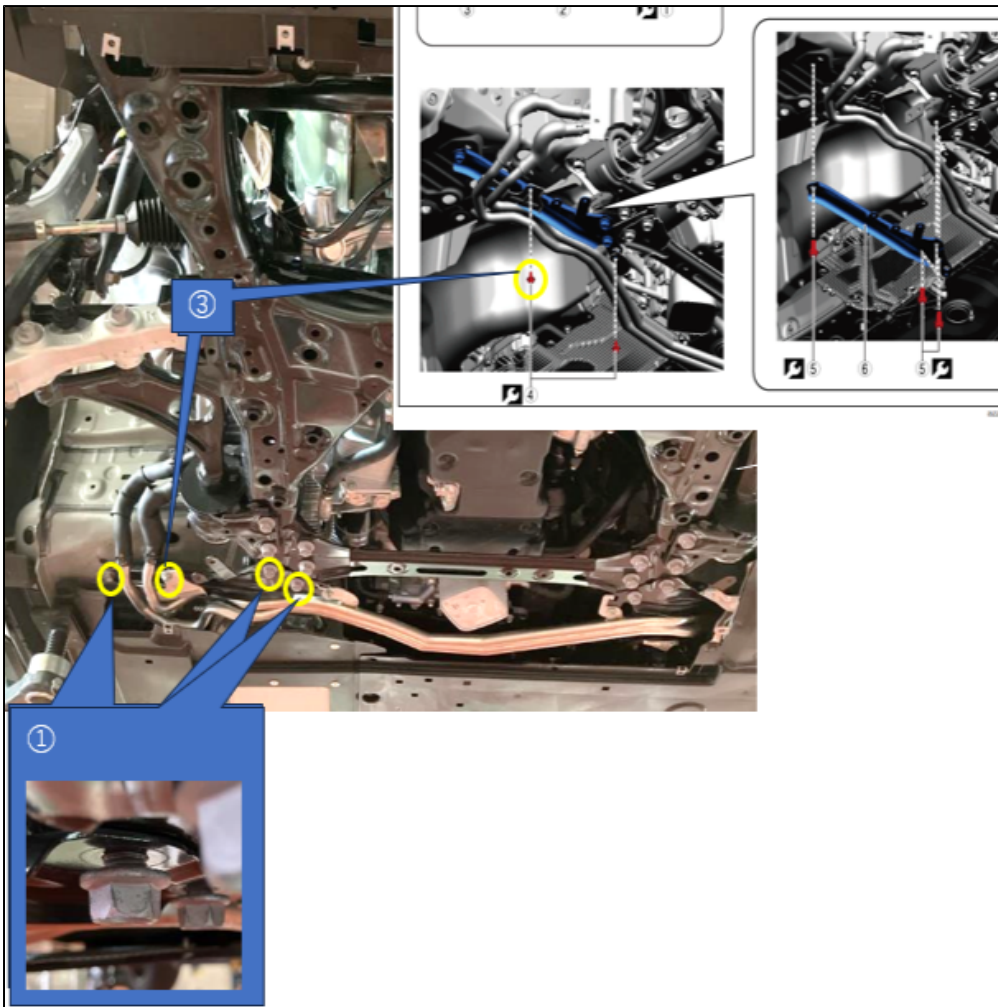

**CONSUMER NOTICE:** The information and instructions in this bulletin are intended for use by skilled technicians. Mazda technicians utilize the proper tools/ equipment and take training to correctly and safely maintain Mazda vehicles. These instructions should not be performed by "do-it-yourselfers." Customers should not assume this bulletin applies to their vehicle or that their vehicle will develop the described concern. To determine if the information applies, customers should contact their nearest authorized Mazda dealership. Mazda North American Operations reserves the right to alter the specifications and contents of this bulletin without obligation or advance notice. All rights reserved. No part of this bulletin may be reproduced in any form or by any means, electronic or mechanical---including photocopying and recording and the use of any kind of information storage and retrieval system ---without permission in writing.

16. Remove the four engine mount bolts (one from underneath and the three from the top that were loosened).

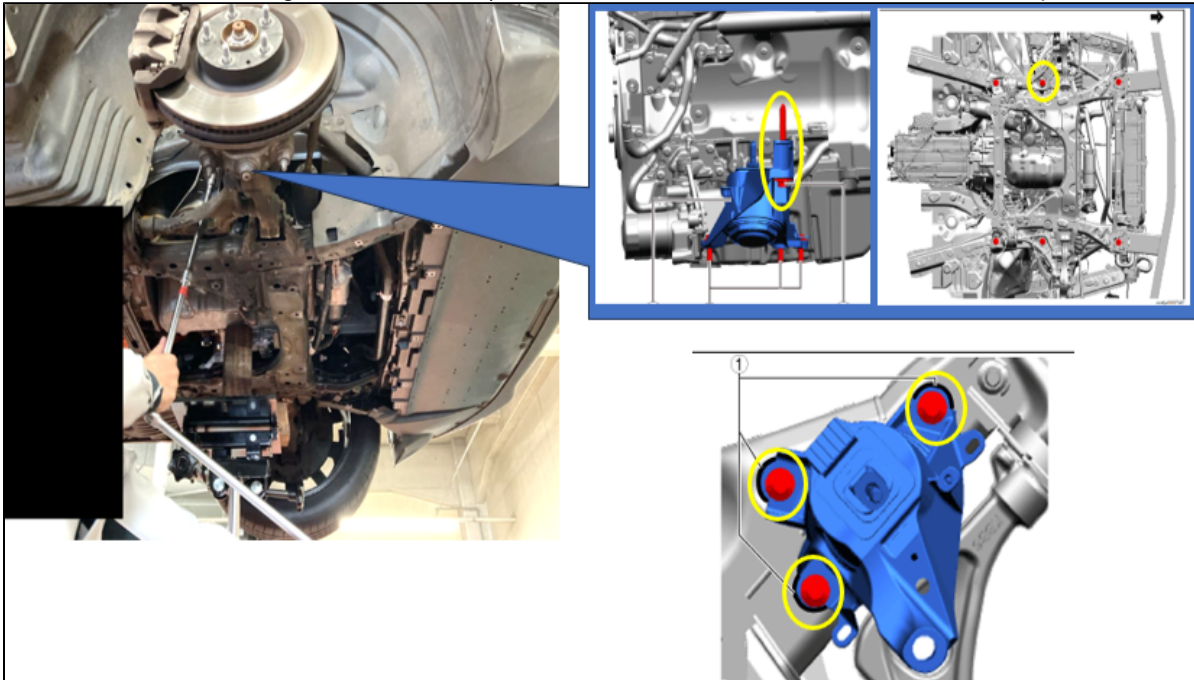

17. Lift the engine approximately 0.4 inch (10 mm) to unload the mount.

**NOTE:** Ensure you lift only enough so that a slight gap appears between the engine mount and the engine bracket.

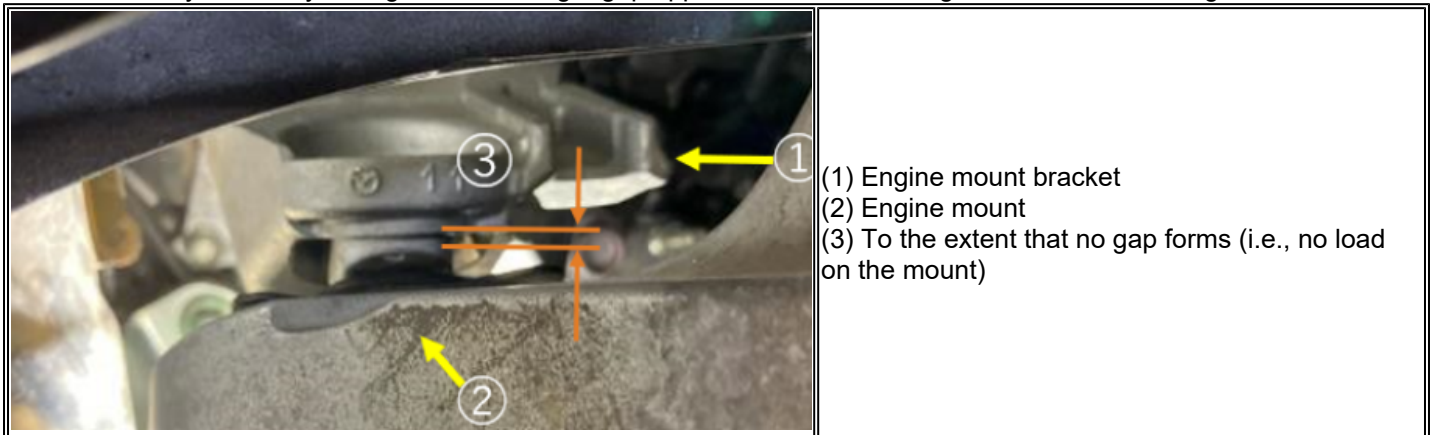

**CONSUMER NOTICE:** The information and instructions in this bulletin are intended for use by skilled technicians. Mazda technicians utilize the proper tools/ equipment and take training to correctly and safely maintain Mazda vehicles. These instructions should not be performed by "do-it-yourselfers." Customers should not assume this bulletin applies to their vehicle or that their vehicle will develop the described concern. To determine if the information applies, customers should contact their nearest authorized Mazda dealership. Mazda North American Operations reserves the right to alter the specifications and contents of this bulletin without obligation or advance notice. All rights reserved. No part of this bulletin may be reproduced in any form or by any means, electronic or mechanical---including photocopying and recording and the use of any kind of information storage and retrieval system ---without permission in writing.

18. Remove the engine mount.

a. Pull the engine mount out toward the wheelhouse.



b. Replace the stopper rubber (2) with a modified part.

**NOTE:** Ensure correct orientation and that the marked side faces upward; no adhesive is required.

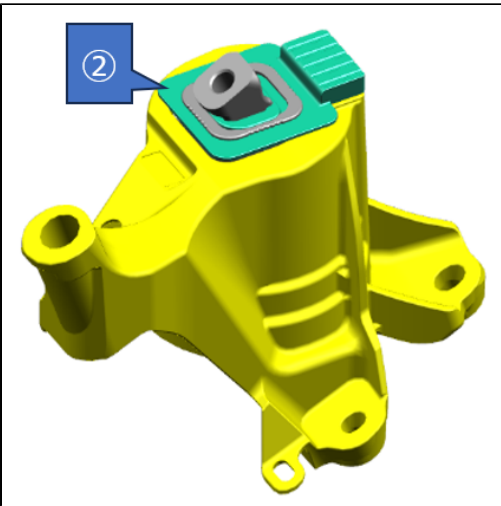

**CONSUMER NOTICE:** The information and instructions in this bulletin are intended for use by skilled technicians. Mazda technicians utilize the proper tools/ equipment and take training to correctly and safely maintain Mazda vehicles. These instructions should not be performed by "do-it-yourselfers." Customers should not assume this bulletin applies to their vehicle or that their vehicle will develop the described concern. To determine if the information applies, customers should contact their nearest authorized Mazda dealership. Mazda North American Operations reserves the right to alter the specifications and contents of this bulletin without obligation or advance notice. All rights reserved. No part of this bulletin may be reproduced in any form or by any means, electronic or mechanical---including photocopying and recording and the use of any kind of information storage and retrieval system ---without permission in writing.

c. Use a scraper to remove any debris (1)



d. Install the stopper rubber with the marked side facing upward.

**NOTE:** The stopper rubber is black, identical to the original part.

Marking colors (3):

KRY0-39-040: Pink (PHEV)

KSY0-39-040: Blue (H3T)

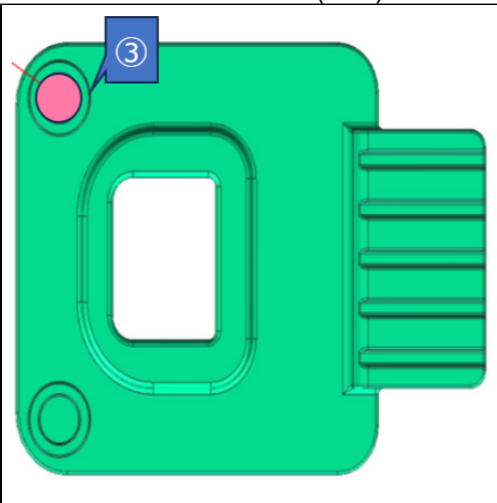

**CONSUMER NOTICE:** The information and instructions in this bulletin are intended for use by skilled technicians. Mazda technicians utilize the proper tools/ equipment and take training to correctly and safely maintain Mazda vehicles. These instructions should not be performed by "do-it-yourselfers." Customers should not assume this bulletin applies to their vehicle or that their vehicle will develop the described concern. To determine if the information applies, customers should contact their nearest authorized Mazda dealership. Mazda North American Operations reserves the right to alter the specifications and contents of this bulletin without obligation or advance notice. All rights reserved. No part of this bulletin may be reproduced in any form or by any means, electronic or mechanical---including photocopying and recording and the use of any kind of information storage and retrieval system ---without permission in writing.

e. Install so that it hooks onto the tabs (2).

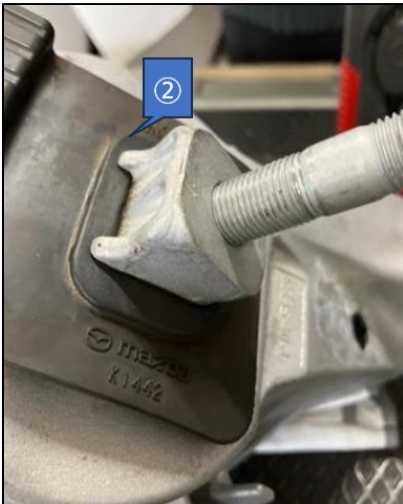

f. Tighten the engine mount bolts to the specified torque with the vehicle lifted.

**Tightening torque: 72 ft·lbf (97.6 N·m; 9.95 kgf·m)**

**NOTE: DO NOT install the engine mount stud (3) at this time.**

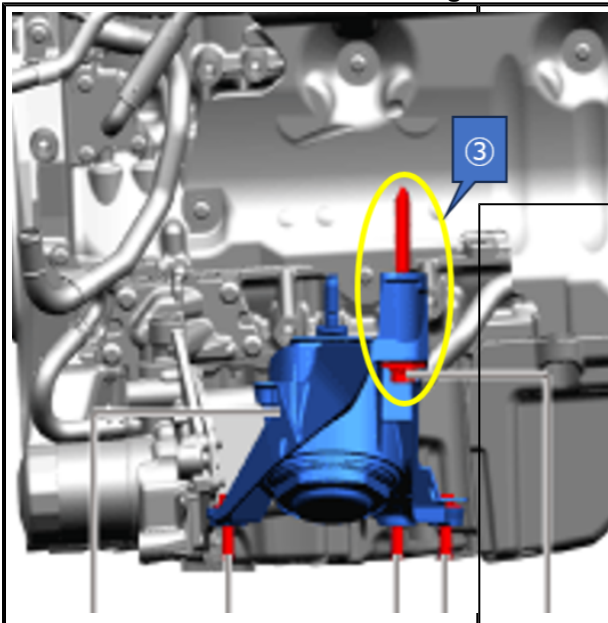

Symbol	Content
① ②...	Servicing order
	Temporarily tighten
	36.9 ft·lbf (50 N·m; 5.1 kgf·m)

g. Tighten the right-side member bracket bolts.

h. Tighten the crossmember bolts.

i. Tighten the heater hose bracket bolt.

j. Remove the jack after all nuts and bolts are tightened.

**NOTE: The engine mount stud should NOT be installed at this time.**

k. Lower the vehicle until all tires contact the ground except for the right front.

**NOTE: The right front tire should NOT be installed at this time.**

**CONSUMER NOTICE:** The information and instructions in this bulletin are intended for use by skilled technicians. Mazda technicians utilize the proper tools/ equipment and take training to correctly and safely maintain Mazda vehicles. These instructions should not be performed by "do-it-yourselfers." Customers should not assume this bulletin applies to their vehicle or that their vehicle will develop the described concern. To determine if the information applies, customers should contact their nearest authorized Mazda dealership. Mazda North American Operations reserves the right to alter the specifications and contents of this bulletin without obligation or advance notice. All rights reserved. No part of this bulletin may be reproduced in any form or by any means, electronic or mechanical--including photocopying and recording and the use of any kind of information storage and retrieval system ---without permission in writing.

l. Use a floor jack to lift the engine until the mount and bracket touch.



**NOTE:** When jacking up the oil pan, place cushioning material (e.g., a rubber pad or wooden block) between the jack and the pan.



m. Verify the stud bolts and bracket holes are aligned.

n. Install the engine mount stud and torque it to spec.

**NOTE:** The nut should NOT be installed at this time.

Symbol	Content
	25.1 ft·lbf (34 N·m; 3.45 kgf·m)

**CONSUMER NOTICE:** The information and instructions in this bulletin are intended for use by skilled technicians. Mazda technicians utilize the proper tools/ equipment and take training to correctly and safely maintain Mazda vehicles. These instructions should not be performed by "do-it-yourselfers." Customers should not assume this bulletin applies to their vehicle or that their vehicle will develop the described concern. To determine if the information applies, customers should contact their nearest authorized Mazda dealership. Mazda North American Operations reserves the right to alter the specifications and contents of this bulletin without obligation or advance notice. All rights reserved. No part of this bulletin may be reproduced in any form or by any means, electronic or mechanical---including photocopying and recording and the use of any kind of information storage and retrieval system ---without permission in writing.

- o. Ensure a zero-contact position before tightening.  
1) Zero-touch position (1).



- 2) Lightly push the engine-mount stud (2) with your finger; if it can be moved only slightly, you've reached the 0-touch position. If it moves freely without much resistance, lower the engine slightly and recheck.



**CONSUMER NOTICE:** The information and instructions in this bulletin are intended for use by skilled technicians. Mazda technicians utilize the proper tools/ equipment and take training to correctly and safely maintain Mazda vehicles. These instructions should not be performed by "do-it-yourselfers." Customers should not assume this bulletin applies to their vehicle or that their vehicle will develop the described concern. To determine if the information applies, customers should contact their nearest authorized Mazda dealership. Mazda North American Operations reserves the right to alter the specifications and contents of this bulletin without obligation or advance notice. All rights reserved. No part of this bulletin may be reproduced in any form or by any means, electronic or mechanical---including photocopying and recording and the use of any kind of information storage and retrieval system ---without permission in writing.

3) Verify that the stud (3) and the engine-bracket bolt holes are aligned in the same positions as shown in the photo.

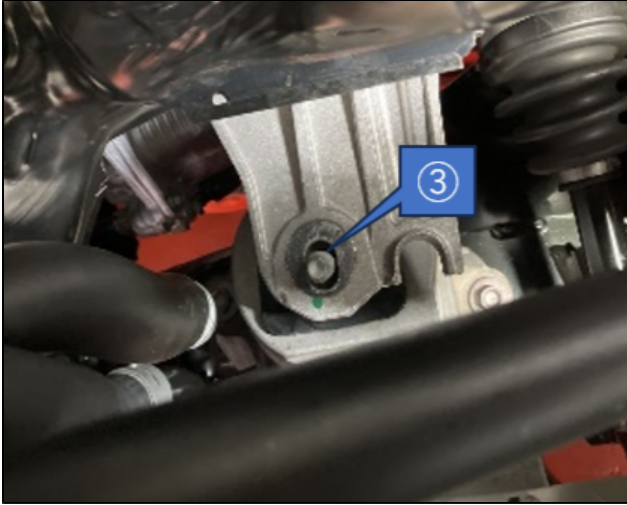

- If they are not correctly aligned even in the zero-touch position, shift the stud bolts or the engine laterally to achieve proper alignment.
  - DO NOT over-lift or under-lift the engine during tightening.
- NOTE: Before tightening, ensure that the engine mount and engine bracket are in a zero contact (0-touch position), and that the position of the stud bolt and the bolt hole in the engine bracket matches the OK position shown in the photo. If the position is not in the OK location even in the zero contact (0-touch position), manually adjust the engine position. Be careful not to tighten the nut while the engine is excessively jacked up, as this may lead to loosening of the fastening. Also, avoid tightening the nut when the engine mount and engine bracket are excessively pressed together (i.e., when the engine is not jacked up enough), as this may result in excessively small clearance between the engine bracket and the stopper rubber.**

### Correct alignment position



**CONSUMER NOTICE:** The information and instructions in this bulletin are intended for use by skilled technicians. Mazda technicians utilize the proper tools/ equipment and take training to correctly and safely maintain Mazda vehicles. These instructions should not be performed by "do-it-yourselfers." Customers should not assume this bulletin applies to their vehicle or that their vehicle will develop the described concern. To determine if the information applies, customers should contact their nearest authorized Mazda dealership. Mazda North American Operations reserves the right to alter the specifications and contents of this bulletin without obligation or advance notice. All rights reserved. No part of this bulletin may be reproduced in any form or by any means, electronic or mechanical--including photocopying and recording and the use of any kind of information storage and retrieval system ---without permission in writing.

**NOTE:** The image below shows an engine that has not been lifted enough (1) or an engine that has been lifted too high (2).

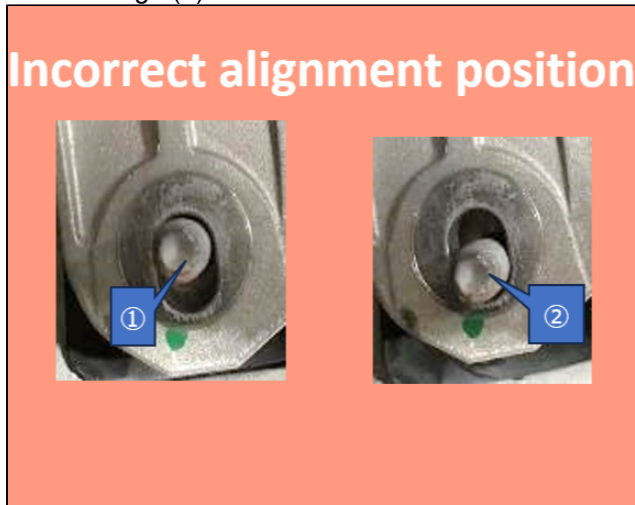

4) Lightly tighten the mount nut to 5 ft-lbs (6.8 Nm) on the engine mount stud.

5) Raise the vehicle and measure the gap (left image (1)) between the engine bracket (right image (2)) and the stopper rubber (right image (1)) using a taper gauge or stacked feeler gauges.

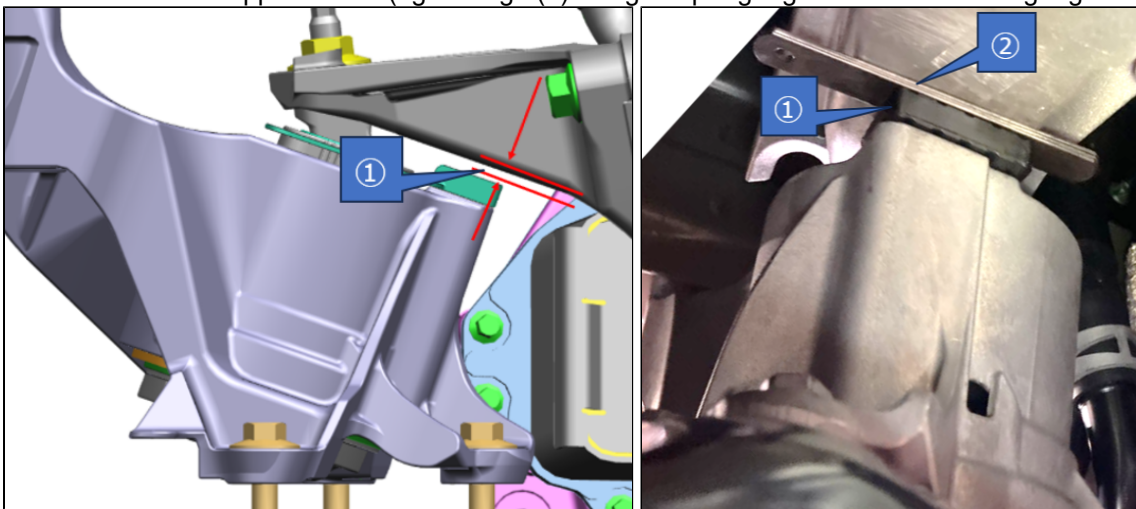

**CONSUMER NOTICE:** The information and instructions in this bulletin are intended for use by skilled technicians. Mazda technicians utilize the proper tools/ equipment and take training to correctly and safely maintain Mazda vehicles. These instructions should not be performed by "do-it-yourselfers." Customers should not assume this bulletin applies to their vehicle or that their vehicle will develop the described concern. To determine if the information applies, customers should contact their nearest authorized Mazda dealership. Mazda North American Operations reserves the right to alter the specifications and contents of this bulletin without obligation or advance notice. All rights reserved. No part of this bulletin may be reproduced in any form or by any means, electronic or mechanical---including photocopying and recording and the use of any kind of information storage and retrieval system ---without permission in writing.

Engine	Clearance	Suggested Feeler Gauge Combination		
PYUL	0.18 in (4.5 mm)	<b>Order</b>	<b>Size (in)</b>	<b>Size (mm)</b>
		1 (Top)	0.0250 in	0.635 mm
		2	0.0240 in	0.610 mm
		3	0.0230 in	0.584 mm
		4	0.0220 in	0.559 mm
		5	0.0050 in	0.127 mm
		6	0.0180 in	0.457 mm
		7	0.0190 in	0.483 mm
		8	0.0200 in	0.508 mm
		9 (Bottom)	0.0210 in	0.533 mm
		<b>Total Thickness</b>	<b>0.1770 in (4.496 mm)</b>	
		<b>NOTE: Insert the feeler gauges in the suggested order—thickest on the outside, thinnest in the center—to reduce the risk of damaging the thinner strip.</b>		
H3T	0.15 in (3.8 mm)	<b>Order</b>	<b>Size (in)</b>	<b>Size (mm)</b>
		1 (Top)	0.032 in	0.813 mm
		2	0.025 in	0.635 mm
		3	0.026 in	0.660 mm
		4	0.009 in	0.229 mm
		5	0.028 in	0.711 mm
		6 (Bottom)	0.030 in	0.762 mm
		<b>Total Thickness</b>	<b>0.150 in (3.810 mm)</b>	
<b>NOTE: Insert the feeler gauges in the suggested order—thickest on the outside, thinnest in the center—to reduce the risk of damaging the thinner strip.</b>				

- If the gap is below the specified value, return to the previous step and recheck that the stud bolts and engine bracket are aligned in the correct position, then adjust their alignment.
- If you cannot achieve the required gap by adjusting only the right engine mount, remove the nuts that secure the left engine mount and engine bracket, and shift the left mount to place it in the centered position, as shown for the left mount (no gap measurement is required on the left side).
- If you still cannot adjust the gap within specification after adjusting both engine mounts, replace both engine mounts—performing the replacement one side at a time, following this procedure. Loosen the crossmember bolts one side at a time; loosening both sides simultaneously may cause wheel-alignment deviation.
- When replacing with a new engine mount, it is not necessary to transfer the stopper rubber to the new engine mount.

19. Install the right front (RF) tire using the procedure in [FRONT UNDER COVER REMOVAL/INSTALLATION].

**CONSUMER NOTICE:** The information and instructions in this bulletin are intended for use by skilled technicians. Mazda technicians utilize the proper tools/ equipment and take training to correctly and safely maintain Mazda vehicles. These instructions should not be performed by "do-it-yourselfers." Customers should not assume this bulletin applies to their vehicle or that their vehicle will develop the described concern. To determine if the information applies, customers should contact their nearest authorized Mazda dealership. Mazda North American Operations reserves the right to alter the specifications and contents of this bulletin without obligation or advance notice. All rights reserved. No part of this bulletin may be reproduced in any form or by any means, electronic or mechanical—including photocopying and recording and the use of any kind of information storage and retrieval system ---without permission in writing.

20. Lower the vehicle fully to the ground.
21. Tighten the engine mount nuts to the specified torque with the vehicle's full weight resting on its tires.
22. Install the mudguard bolts and fasteners.
23. Install the right-side (passenger side) front splash shield No.2 using the procedure in [FRONT UNDER COVER REMOVAL/INSTALLATION].
24. Install the front under covers No.1, No.2, and No.3 using the steps in [FRONT UNDER COVER REMOVAL/INSTALLATION].
25. Install the right front (RF) tire using the procedure in [FRONT UNDER COVER REMOVAL/INSTALLATION].
26. Install the heat insulator bolts.
27. Install the engine cover.
28. Reconnect the negative battery terminal using the procedure in [NEGATIVE BATTERY TERMINAL DISCONNECTION/CONNECTION].
29. Verify the repair.

### PARTS INFORMATION

Parts Number	Description	Q'ty	Notes
KRY0-39-040	Rub-E/Mtg; RH, Stopper	1	PHEV (Pink dot)
KSY0-39-040		1	H3T (Blue dot)

### Order only when necessary

Parts Number	Description	Q'ty	Notes
KR9P-39-040*	Rubber No.1, Eng. Mtg. <b>NOTE:</b> Right engine mount	1	PHEV
KS0E-39-040*		1	H3T
KR9P-39-050*	Rubber (L), Engine Mt. <b>NOTE:</b> Left engine mount	1	PHEV
KS0E-39-050*		1	H3T

**NOTE:** If the adjustment of both engine mounts does not bring them within the specified range, replace both engine mounts.

**CONSUMER NOTICE:** The information and instructions in this bulletin are intended for use by skilled technicians. Mazda technicians utilize the proper tools/ equipment and take training to correctly and safely maintain Mazda vehicles. These instructions should not be performed by "do-it-yourselfers." Customers should not assume this bulletin applies to their vehicle or that their vehicle will develop the described concern. To determine if the information applies, customers should contact their nearest authorized Mazda dealership. Mazda North American Operations reserves the right to alter the specifications and contents of this bulletin without obligation or advance notice. All rights reserved. No part of this bulletin may be reproduced in any form or by any means, electronic or mechanical--including photocopying and recording and the use of any kind of information storage and retrieval system ---without permission in writing.

**WARRANTY INFORMATION****NOTE:**

- This warranty information applies only to verified customer complaints on vehicles eligible for warranty repair.
- This repair will be covered under Mazda's **Powertrain** Limited Warranty term.
- Additional diagnostic time cannot be claimed for this repair.

Symptom Code	82		
Damage Code	97		
Causal Part No.	KRY0-39-040 or KSY0-39-040		
Quantity	1		
Operation No. and Labor Hours	Replace right engine mount stopper rubber (PHEV)	XXX37ERX	2.3H
	Replace right engine mount stopper rubber (H3T)	XXX37FRX	2.4H
	Replace right engine mount stopper rubber + readjust right engine mount installation position (PHEV)	XXX37GRX	2.7H
	Replace right engine mount stopper rubber + readjust right engine mount installation position (H3T)	XXX37HRX	2.8H
	Replace right engine mount stopper rubber + readjust right engine mount installation position + adjust left engine mount installation position (PHEV)	XXX37KRX	3.2H
	Replace right engine mount stopper rubber + readjust right engine mount installation position + adjust left engine mount installation position (H3T)	XXX37LRX	3.3H
	Replace right engine mount stopper rubber + readjust right engine mount installation position + adjust left engine mount installation position + replace both engine mounts (PHEV)	XXX37MRX	5.7H
	Replace right engine mount stopper rubber + readjust right engine mount installation position + adjust left engine mount installation position + replace both engine mounts (H3T)	XXX37NRX	5.8H
Period Covered	Basic Warranty Period		

**NOTE:** Claim other parts except causal part as related parts

**CONSUMER NOTICE:** The information and instructions in this bulletin are intended for use by skilled technicians. Mazda technicians utilize the proper tools/ equipment and take training to correctly and safely maintain Mazda vehicles. These instructions should not be performed by "do-it-yourselfers." Customers should not assume this bulletin applies to their vehicle or that their vehicle will develop the described concern. To determine if the information applies, customers should contact their nearest authorized Mazda dealership. Mazda North American Operations reserves the right to alter the specifications and contents of this bulletin without obligation or advance notice. All rights reserved. No part of this bulletin may be reproduced in any form or by any means, electronic or mechanical--including photocopying and recording and the use of any kind of information storage and retrieval system ---without permission in writing.