



STAR ONLINE PUBLICATION



Case Number: S2609000009

Release Date: June 2026

Symptom/Vehicle Issue: Check Engine Light (CEL) Illuminated with Diagnostic Trouble Code (DTC) P0106 Manifold Absolute Pressure Sensor Performance Setting In The Powertrain Control Module (PCM)

Models Affected:

2020-2023 Jeep Wrangler 3.0L (JL)

2021-2023 Jeep Gladiator 3.0L (JT)

2020-2023 RAM 1500 3.0L (DT)

Owner Complaint/Technician Observation: Technician may find that DTC P0106 is setting after replacing the intake manifold. At this time the Manifold Absolute Pressure (MAP) sensor that is installed on the new manifold is incorrect and will need to be replaced with the correct MAP sensor for your application or transfer the MAP sensor from the original intake manifold.

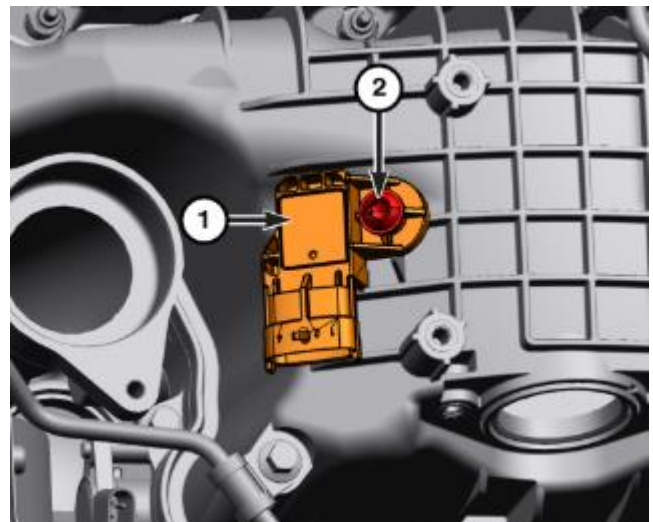
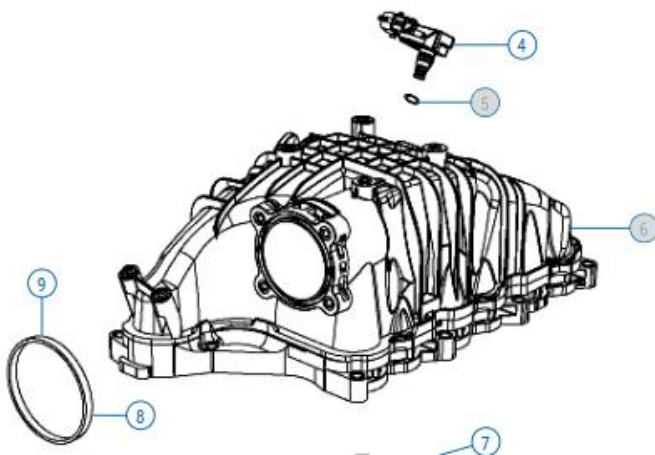

This document does not authorize warranty repairs. This communication documents a record of past experiences. STAR Online does not provide any conclusions about what is wrong with the vehicle. Rather, it captures all previous case details that appear to be similar or related to the vehicle symptom / condition. You are the expert, and you are responsible for deciding on the appropriate course of action.

Contact STAR Center, or your Technical Assistance Center Via TechConnect, eCONTACT or Service Library entry if no solution is found.