

ATTENTION:

- GENERAL MANAGER
- PARTS MANAGER
- CLAIMS PERSONNEL
- SERVICE MANAGER

IMPORTANT - All Service Personnel Should Read and Initial in the boxes provided, right.

© 2026 Subaru of America, Inc. All rights reserved.



QUALITY DRIVEN® SERVICE

SERVICE INFORMATION BULLETIN

APPLICABILITY: 2026+ Outback 2.5L
 2026+ Impreza & Crosstrek 2.5L
 2026+ Forester

NUMBER: 18-243-26
DATE: 06/10/26

SUBJECT: FB2.5 Oil Spacer / Service Manual Correction

INTRODUCTION:

This service information bulletin announces the elimination of oil spacers from both left- and right-side camshaft carriers on FB2.5 engines. Oil spacers and related hardware were removed during some production stages. This update does not affect performance and will be added to the Service Manual in the future.

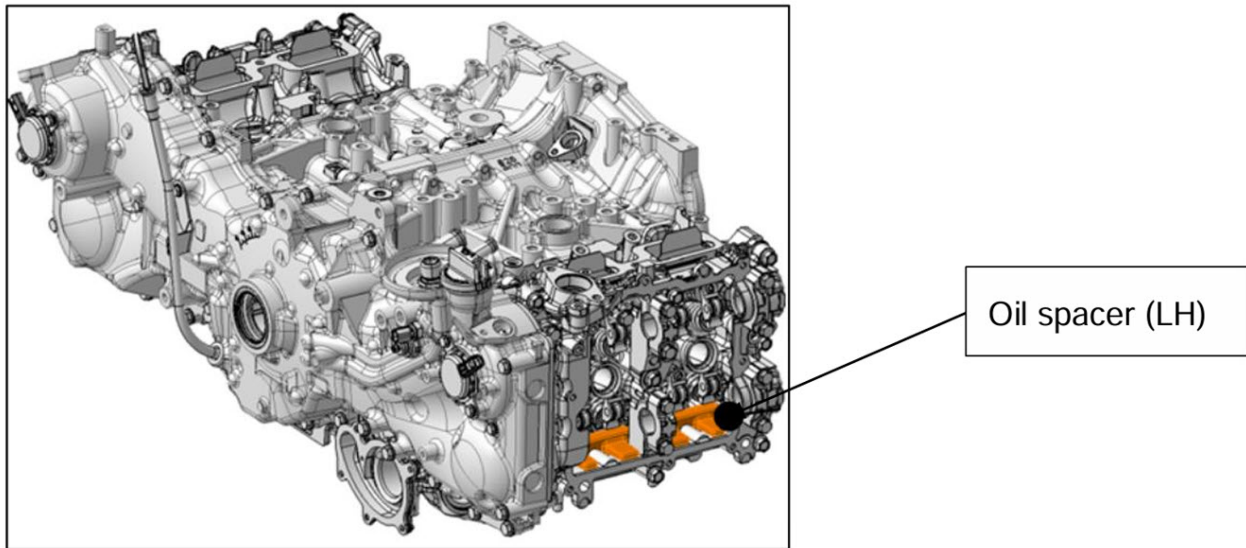

CAUTION: VEHICLE SERVICING PERFORMED BY UNTRAINED PERSONS COULD RESULT IN SERIOUS INJURY TO THOSE PERSONS OR TO OTHERS.

Subaru Service Bulletins are intended for use by professional technicians ONLY. They are written to inform those technicians of conditions that may occur in some vehicles, or to provide information that could assist in the proper servicing of the vehicle. Properly trained technicians have the equipment, tools, safety instructions, and know-how to do the job correctly and safely. If a condition is described, DO NOT assume that this Service Bulletin applies to your vehicle, or that your vehicle will have that condition.

Subaru of America, Inc. is ISO 14001 Compliant

ISO 14001 is the international standard for excellence in Environmental Management Systems. Please recycle or dispose of automotive products in a manner that is friendly to our environment and in accordance with all local, state and federal laws and regulations.

Continued...

SERVICE PROCEDURE / INFORMATION:

REMINDER: Customer satisfaction and retention starts with performing quality repairs.

Some FB2.5 engines removed oil spacers from production. If oil spacers are missing during camshaft carrier servicing, there is no need to install new ones. If the engine has oil spacers and they are removed during servicing, reinstall them as per the applicable Service Manual.

4. Install the oil spacer to the cam carrier

Tightening torque:

6.4 N·m (0.7 kgf-m, 4.7 ft-lb)

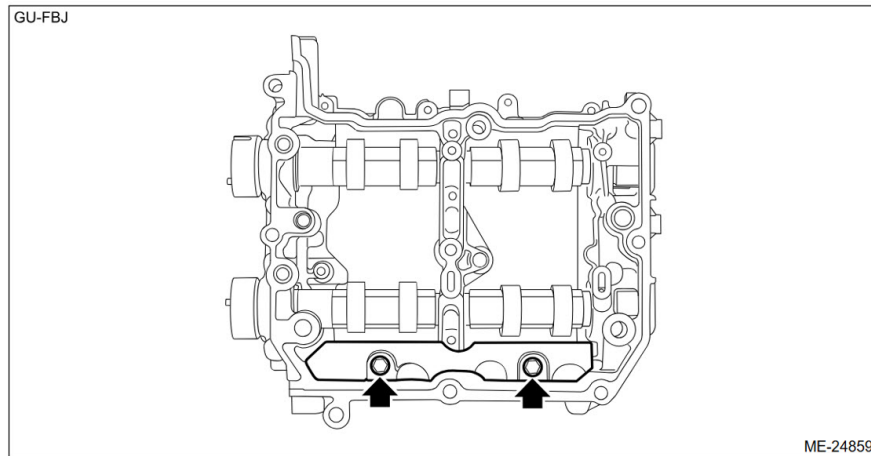

IMPORTANT REMINDERS:

- SOA strongly discourages the printing and/or local storage of service information as previously released information and electronic publications may be updated at any time.
- Always check for any open recalls or campaigns anytime a vehicle is in for servicing.
- Always refer to STIS for the latest service information before performing any repairs.