

- ATTENTION:**
- GENERAL MANAGER
  - PARTS MANAGER
  - CLAIMS PERSONNEL
  - SERVICE MANAGER

IMPORTANT - All Service Personnel Should Read and Initial in the boxes provided, right.

© 2026 Subaru of America, Inc. All rights reserved.



QUALITY DRIVEN® SERVICE

## SERVICE BULLETIN

**APPLICABILITY:** 2025MY Forester

**NUMBER:** 12-268-26

**SUBJECT:** Hood Release Lever Design Change

**DATE:** 06/10/26

### INTRODUCTION:

This bulletin announces a design change to the front hood release lever. In certain circumstances, after the vehicle’s interior latch has been released, the front hood may fail to open when attempting to operate the exterior latch. This issue can occur due to insufficient contact between the front hood lever and the hood lock stopper. To address this, the new lever has been fitted with a PVC coating to ensure proper contact and reliable operation. If a customer reports difficulty opening the hood, replace the hood release lever using the part specified in this bulletin.

### PRODUCTION CHANGE INFORMATION:

The new hood release lever has been incorporated into vehicle production as per the table below.

Model	Starting VIN
FORESTER	SH469930

### DESCRIPTION OF DESIGN CHANGE:

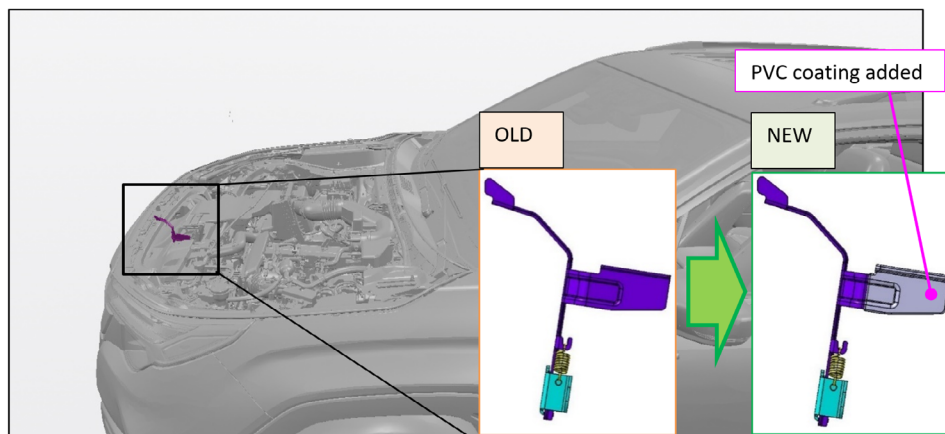

<p><b>CAUTION: VEHICLE SERVICING PERFORMED BY UNTRAINED PERSONS COULD RESULT IN SERIOUS INJURY TO THOSE PERSONS OR TO OTHERS.</b></p> <p>Subaru Service Bulletins are intended for use by professional technicians ONLY. They are written to inform those technicians of conditions that may occur in some vehicles, or to provide information that could assist in the proper servicing of the vehicle. Properly trained technicians have the equipment, tools, safety instructions, and know-how to do the job correctly and safely. If a condition is described, DO NOT assume that this Service Bulletin applies to your vehicle, or that your vehicle will have that condition.</p>	<p style="text-align: center;"><b>Subaru of America, Inc. is ISO 14001 Compliant</b></p> <p>ISO 14001 is the international standard for excellence in Environmental Management Systems. Please recycle or dispose of automotive products in a manner that is friendly to our environment and in accordance with all local, state and federal laws and regulations.</p>
--	--

*Continued...*

## PART INFORMATION:

**REMINDER:** Always order the most up-to-date replacement parts based on the specific VIN being repaired.

Part Description	Part Number
LEVER ASSEMBLY-FRONT HOOD	57341SL002

## SERVICE PROCEDURE / INFORMATION:

**REMINDER:** Customer satisfaction and retention starts with performing quality repairs.

The service procedures for front hood release lever replacement remain unchanged. Always refer to the applicable Service Manual and review the full requirements of the repair being performed. The Service Manual procedures contain information critical to performing an effective repair the first time, every time. This includes but is not limited to important SAFETY precautions, proper inspection criteria, necessary special tools, required processes and related one-time-use parts needed for a complete and lasting repair.

Refer to STIS: [Body & Electrical/WIRING SYSTEM > SECURITY AND LOCKS > Front Hood Lock Assembly](#)

## WARRANTY / CLAIM INFORMATION:

For vehicles within the Basic New Car Limited or covered by an active Subaru Added Security Gold plan, this repair may be submitted using the following claim information:

Claim Type	Labor Description	Labor Operation #	Labor Time	Fail Code	Dispatch Assignment
WC	HOOD LOCK LEVER R&R	A915186	.3h	SBN-21	SG All / SL 1

The Skill Group and Skill Level listed in this bulletin define the qualifications recommended for this work. Repairs should be dispatched to a technician who is trained at the specified level. For more information on Labor Operation Skill Group/Level assignments, [click here to access the Gear Reduction](#). To request a Skill Group/Skill Level change, [fill out this form](#).

## IMPORTANT REMINDERS:

- SOA strongly discourages the printing and/or local storage of service information as previously released information and electronic publications may be updated at any time.
- Always check for any open recalls or campaigns anytime a vehicle is in for servicing.
- Always refer to STIS for the latest service information before performing any repairs.