

NON-COMPLIANCE RECALL

Volvo Trucks North America

Greensboro, NC USA

Date	Number	Release	Page
09.2024	EC0033	02	1(6)

M0307 SCR Monitoring Software, 13L TC Engine VN

RECALL INFORMATION

Revised 6/2/2026 Added Canada Population

(September 2024)

Volvo Trucks has determined that certain vehicles equipped with a model year (“MY”) 2017-2018 13L Turbo Compound (TC) engine may not meet California and Federal Regulations (CARB). This Recall is for updated software that will reduce the amount of time necessary for the system to operate in a cold engine warm-up strategy and provide health monitoring of the Selective Catalyst Reduction (SCR).

To ensure Volvo remains emission compliant on these vehicles, follow the repair instructions outlined in this document to Program the Engine control Module and the Aftertreatment Control Module. Install a completion label in the door.

VEHICLES AFFECTED

Certain Volvo vehicles manufactured between March 7, 2017, and December 21, 2018.

VEHICLE QUANTITY

There are 2,140 vehicles affected by this recall (1,822 U.S. 318 Canada)

Repair Instructions

1. Park the vehicle on a level surface.
2. Apply the parking brake.
3. Place the gear lever in neutral.
4. Install wheel chocks.

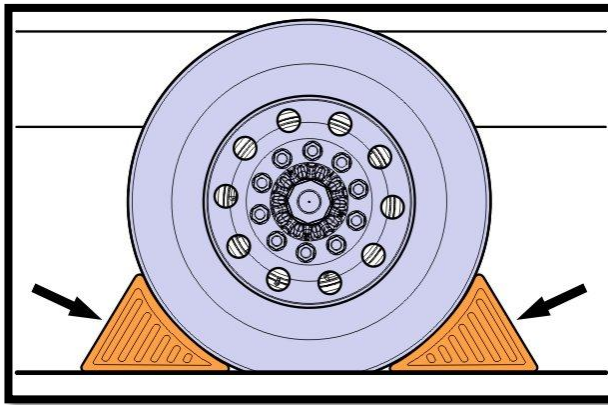

5. Turn on the ignition switch.
6. Log into PTT and connect to the vehicle.
7. Once the vehicle has been identified, enter the work order number, then click Start.
8. From the main menu select the Program tab, then select Program Electronic Control Unit 1700-08-03-39, then click Start.

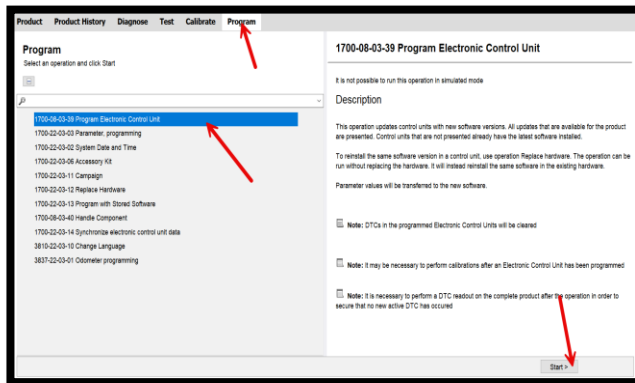

9. Select Engine Control Module (ECM) and Aftertreatment Control Module (ACM).

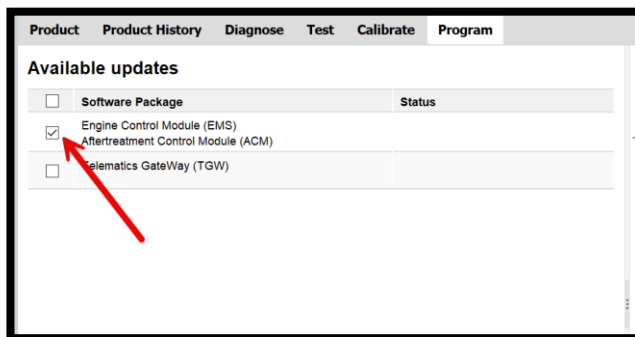

10. Check the Advisory Box, then click Program.

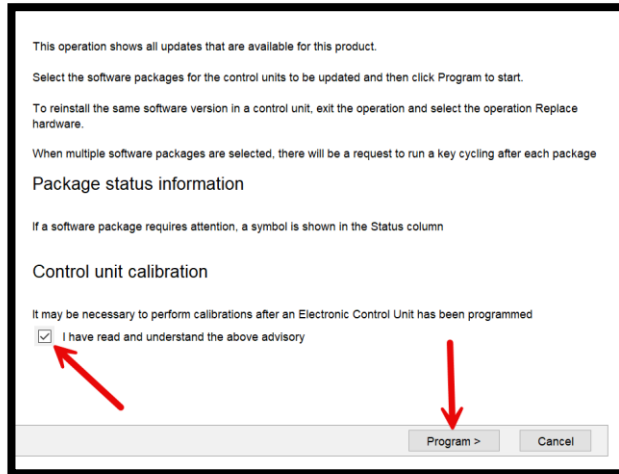

11. Certain conditions must be met to continue with the programming. Once all conditions are met, then click Continue to Start Programming.

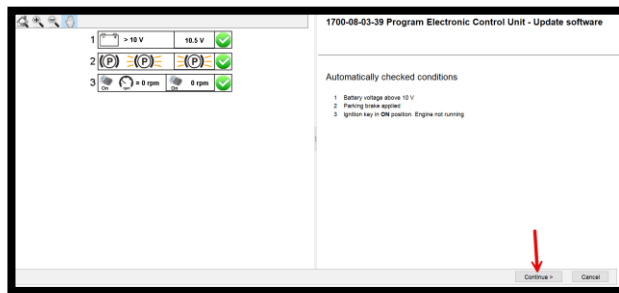

12. Once programming has completed, clear any diagnostic trouble codes (DTC) and Finish Work.

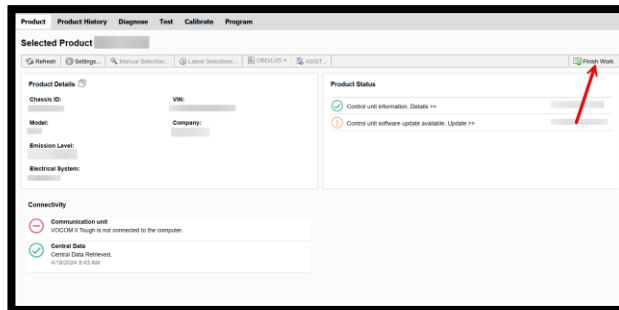

13. Install and fill out the Campaign Completion Label if needed.
14. Remove the wheel chocks.

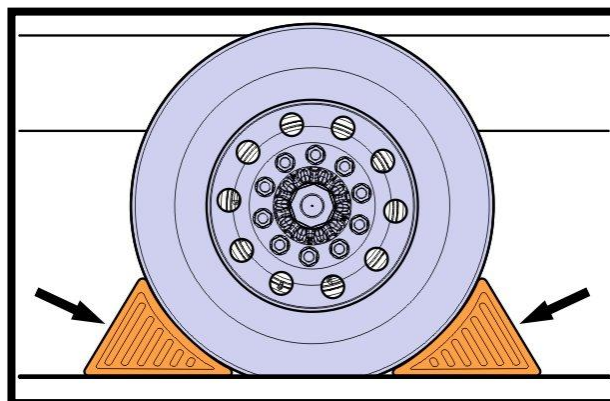

15. Release vehicle to customer.

Important Note!

If needed, print out this Emission Recall Proof of Correction Certificate. Fill in the appropriate information for your records and provide a copy to the customer.

Vehicle Emissions Recall - Proof of Correction

License Number	Make	Year Model	Year Model	Vehicle Identification Number

Manufacturer: _____ Recall Number: _____

The above described vehicle has been repaired, modified to address the Emissions Related Recall that is listed above.

Dealer's _____ Address, City, State _____

Dealer's Authorized Signature _____

X _____

Return this certificate to DMV only when required - otherwise retain for your records.

REIMBURSEMENT

This repair is covered by an authorized Non-Compliance recall. Reimbursement is obtained through the normal claim handling process.	
	UCHP Reimbursement
Claim Type (used only when uploading from the Dealer Business System)	40
Recall Status	
Vehicle repaired per instructions	1-Modified per instructions
Labor code	
2841-22-02-01 ECM and ACM, Reprogramming	0.4
Causal Part	3092091
Authorization Number	M0307

Note: Dealers are to perform Non-Compliance Recall on all subject vehicles at no charge to the vehicle owner regardless of mileage, age of vehicle or ownership (original purchaser or subsequent purchasers). Whenever vehicles are subject to a Non-Compliance Recall are brought to your dealership for service, or taken into your dealership vehicle inventory, it is strongly recommended that every effort be made to perform the recall correction before the vehicle is sold or released to the owner.