



Installation and Operations instructions for Trunk Lid Garnish

- Thank you for purchasing this product.
- This manual provides installation and handling instructions for this product, and precautions to be observed.
- Before using this product, be sure to read "Safety Precautions" and use the product properly.
- Keep this manual in a safe place, such as the glove box, and refer to it whenever necessary.

Important precautions are indicated with the following marks. Be sure to observe those precautions.

Warning	Precautions that you must observe for your safety. [Failure to observe these precautions may result in death or serious injury.]
Caution	Precautions that you must observe for your safety and for your vehicle. [Failure to observe these precautions may result in damages or accidents.]
* Advice	Information that you should familiarize yourself with. Information that are useful.

Warning	
<ul style="list-style-type: none"> • Never attempt to modify this product. This may damage the product and may become cause of serious accidents. • Be sure to stop the engine during work for safety reasons. • Be sure to tighten bolts and nuts firmly. • Inspect the nuts and bolts after the first 60 miles (100 km) of driving after attaching them. Re-tighten them if necessary. • If abnormal noise or vibration occurs while driving, pull over the car immediately to a safe place, and then inspect and re-tighten the attaching bolts. If abnormalities persist, perform inspection and make necessary repairs immediately. If you continue to drive in this condition, damages or accidents may occur. • Stop using this product immediately if it has defects such as deterioration and breakage, or receives a strong impact, as these conditions impair the product's original performance. • Make sure that no part comes in contact with the battery while working. 	

Caution	
<ul style="list-style-type: none"> • This product does not improve the limit performance significantly. Always drive safely. • Do not use this product on inapplicable vehicles or for purposes other than it is designed for. Doing so may result in damages or accidents. • Install this product in accordance with the service manual issued by SUBARU CORPORATION for your model. Also make sure to adhere to the precautions described in this document. • If bolts and nuts are not tightened with specified torque while installing this product, they may be damaged or become loose. Make sure to tighten them with the specified torque. • After installing this product, the fluid should be replenished or changed at a SUBARU dealer. 	

*Advice	
<ul style="list-style-type: none"> • SUBARU shall not be held liable for any direct or indirect damage due to failures or other malfunction caused by incorrect installation or handling of this product. • SUBARU does not honor warranty claims for malfunctions of products or vehicles that occur directly or indirectly due to the installation of this product. • Malfunctions of vehicles that could occur due to the installation of this product may not be covered by the SUBARU vehicle warranty. • When replacing parts with this product, be sure to use genuine SUBARU parts for non-reusable parts, consumables, oil and grease. • Product specifications are subject to change without notice. • Installation of this product may cause deterioration in ride comfort or significant changes in driving characteristics. 	

1. Usage precautions

Caution

- (1) Before opening the product, check that it has no wrinkles, folds or other issues.
- (2) Please note that folding the product can cause issues such as wrinkling or cracking.
- (3) Wrinkling, cracking, and other issues that occur during the application process may not be covered by the warranty.
- (4) Completely remove all wax from the area where the product is to be applied.
- (5) Before applying the product, place it where it is to be applied and check its positioning.
- (6) Remove all grease from the area where the product is to be applied and clean the area thoroughly.
- (7) Perform the work indoors, in an area free of dust.
- (8) Perform the work in a location in which the ambient temperature is 15°C (59°F) or above, and make sure that the temperature of the vehicle and product are also 15°C (59°F) or above. If performing the work in an environment with a temperature below 15°C (59°F), warm the vehicle and the product to 25 to 50°C (77 to 122°F) before performing the work.
- (9) Apply firm pressure to the garnish after applying it to the vehicle.
- (10) After applying the garnish, do not wash the vehicle or expose it to rain for at least 24 hours.
- (11) If chemicals such as wax or coating agents, or solvents such as gasoline or thinner, come in contact with the garnish, they may result in staining or swelling. If any such chemicals or solvents inadvertently come in contact with the garnish, immediately wipe them off.
- (12) Do not perform work with hands which have been dirtied with oil, chemicals, etc.

2. Product numbers and applicable vehicles

Part number	Part name	Applicable vehicle
SG990VA010	STI GARNISH LID RED	WRX S4/STI (VA) all models

3. Contents

Trunk lid garnish x 1 (one of the following two types)

SG990VA010



* Check that all of the above are included before beginning application. If there are any missing or incorrect items, please inform the retailer from whom you purchased the product.

4. Tools

Scissors, ruler, marker, masking tape
 Degreasing agent (recommended: nonane), rag, dryer (when applying the product in a location with an ambient temperature below 15°C (59°F))

5. Appearance when applied

View of vehicle rear



6. Overview of application procedure

(1) Remove the product in its bag from the product box.

* Do not use a sharp object to open the box, as it could damage the product itself.

(2) Open the product bag and remove the product with its backing.

(3) Preparation

* Before starting work, check that the trunk lid garnish is free of wrinkles, folds, or other issues.

Important

* Bending the garnish can cause wrinkling, so take care when handling the garnish throughout the application process.

1) Check that the trunk lid garnish matches the Figure 1 A-A cross section diagram.

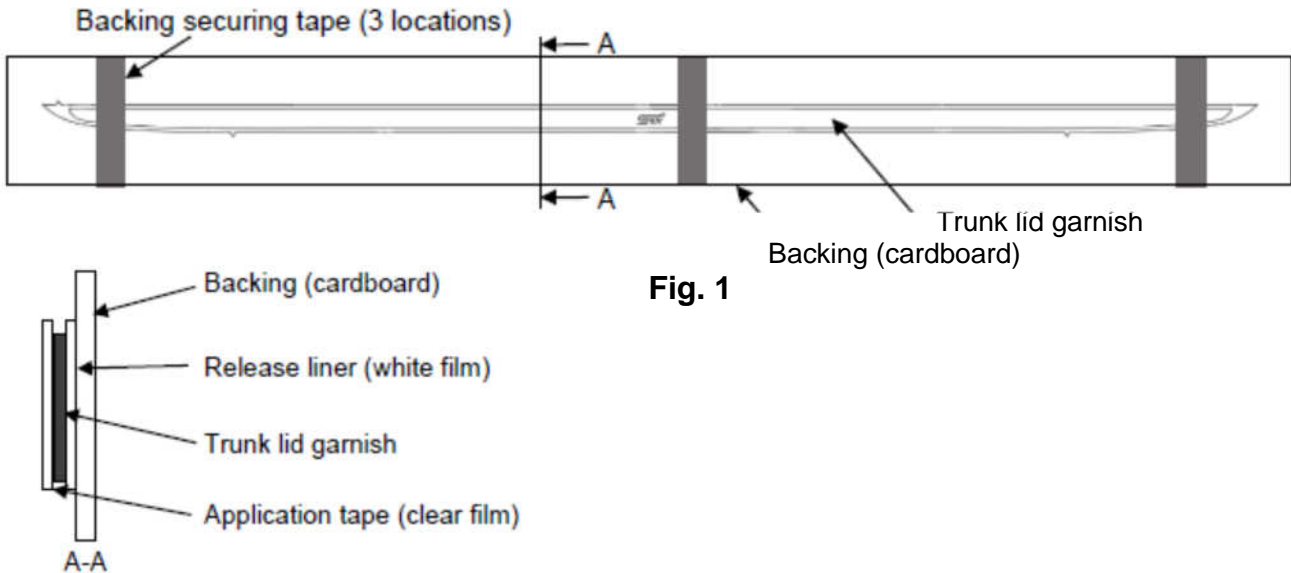

2) Place the product on a flat worktable, with the backing at bottom, and then use the marker to make five marks on the application tape (clear film) as shown in Figure 2.

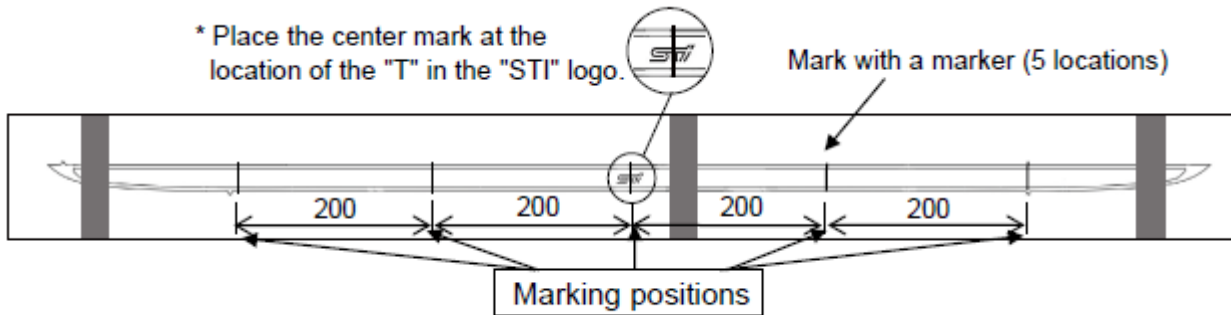

3) As shown in Figure 3, place four pieces of masking tape between the markings. This masking tape will be used to temporarily hold the garnish in place.

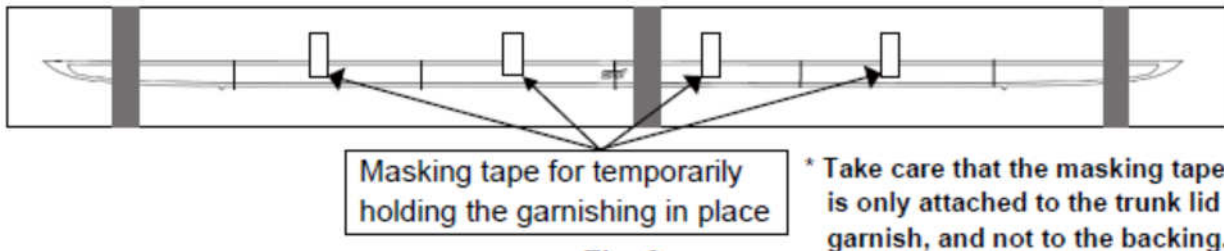

4) As shown in Figure 4, peel off the tape that holds the backing securing tape.

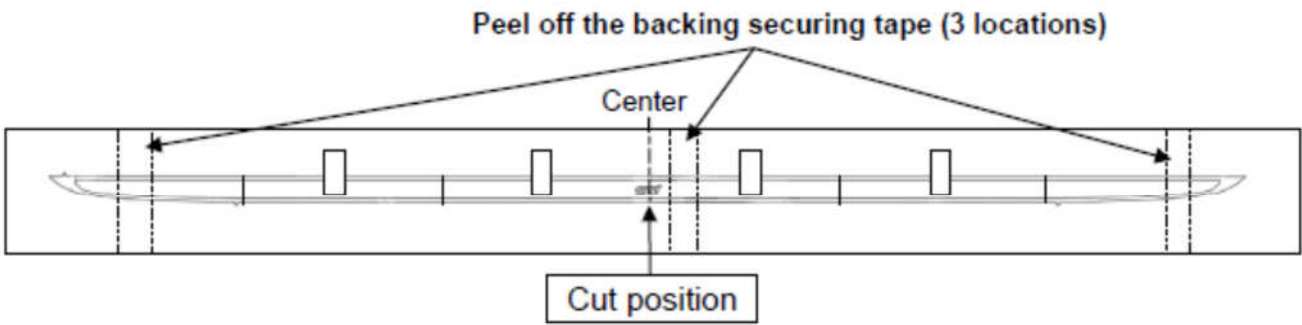

Fig. 4

5) Cut the release liner (white film) at the position of the center marking, as shown in Figure 5.

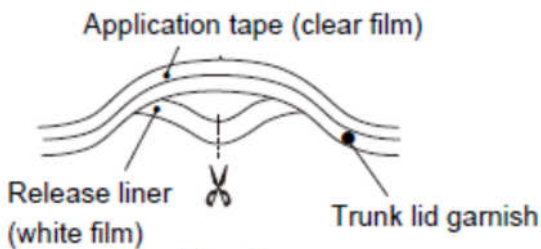
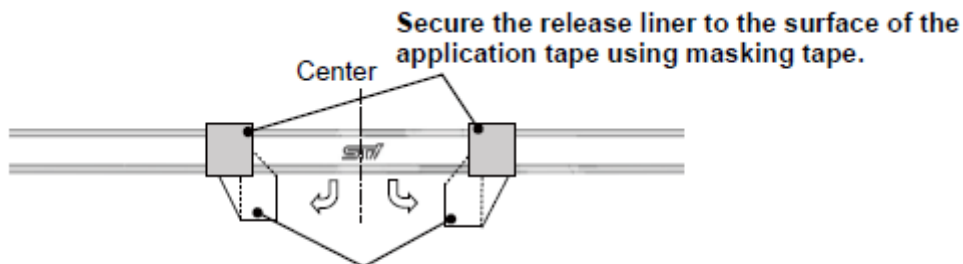

Fig. 5

*** Advice**

- * Perform the work on a flat worktable.
- * Only cut the release liner at the position of the marking at the center of the trunk lid garnish.
- * When cutting the release liner, take care not to cut the trunk lid garnish itself.
- * Take care not to touch the adhesive surface of the garnish.

6) As shown in Figure 6, peel the release liner slightly from the cut point and fold it towards the bottom of the vehicle. Use masking tape to secure the peeled ends of the release liner to the application tape, making it easier to peel off.



Peel the release liner slightly, towards the bottom of the vehicle.

Fig. 6

7) As shown in Figure 7, remove all grease from the area where the trunk lid garnish is to be applied, clean the area thoroughly, and check that there is no wax, etc. remaining on the area.

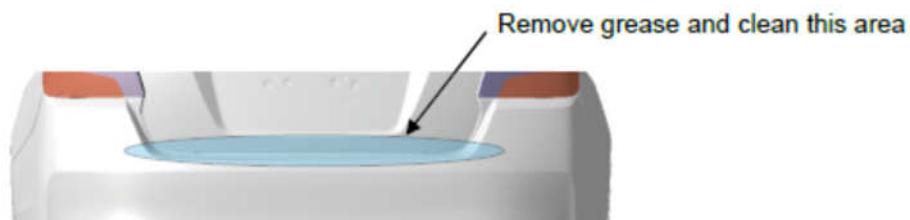

Fig. 7

(2) Positioning

1) With the trunk lid partly open, use the latch center as a guide to position the center of the trunk lid garnish (the "T" in the "STI" logo).

Gently affix the portion of the garnish from which the release liner has been peeled away.

2) As shown in Figure 8, align the application tape on the top of the trunk lid garnish with the bottom edge of the trunk lid and secure it temporarily in place with the masking tape attached to the trunk lid garnish in step (1)-3.

Important

- 3) Step back from the vehicle, far enough that you can see the entire trunk lid, and check that the garnish is positioned correctly both horizontally and vertically.

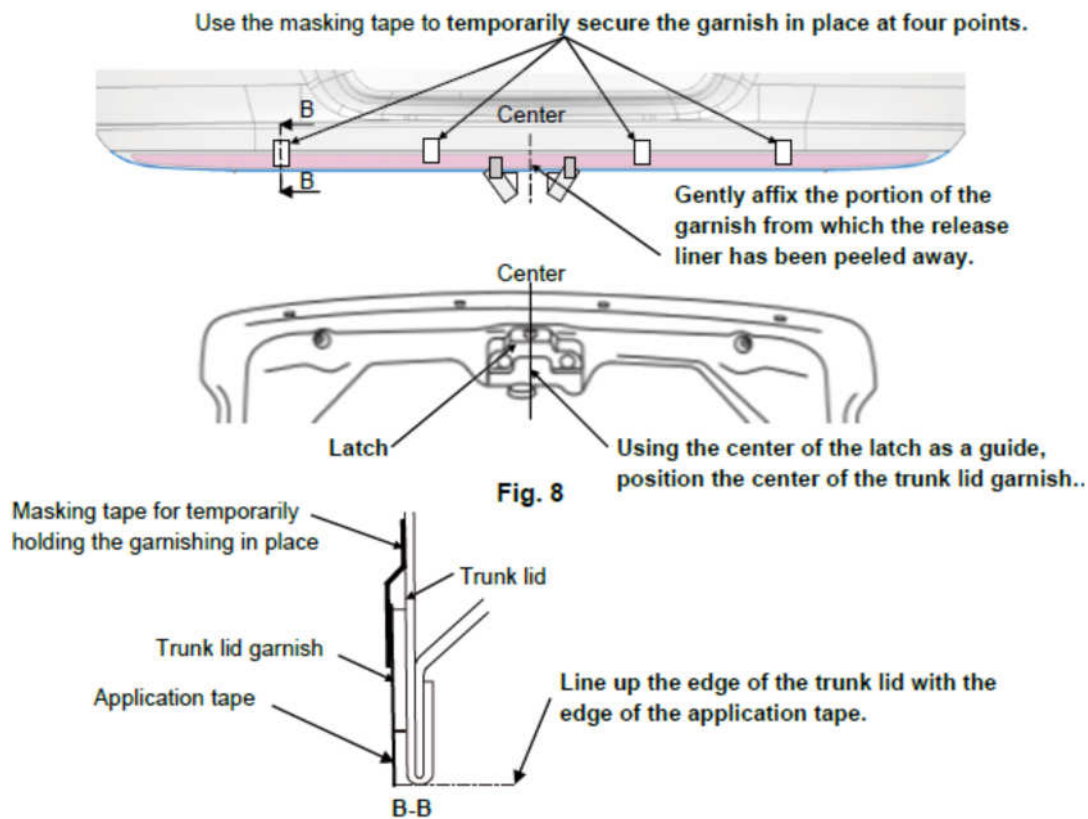

- 4) As shown in Figure 9, place masking tape at the markings on the application tape to assist with positioning the garnish.
Line up the tape with the top edge of the application tape.

- 5) Use the marker to mark the positioning masking tape, aligned with the application tape.

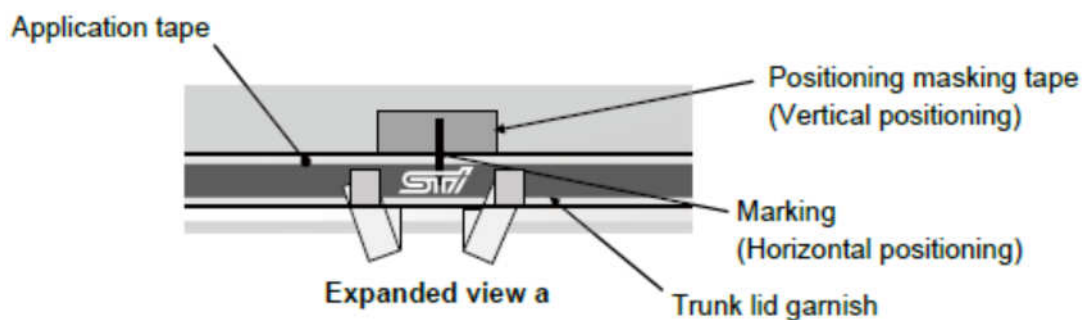
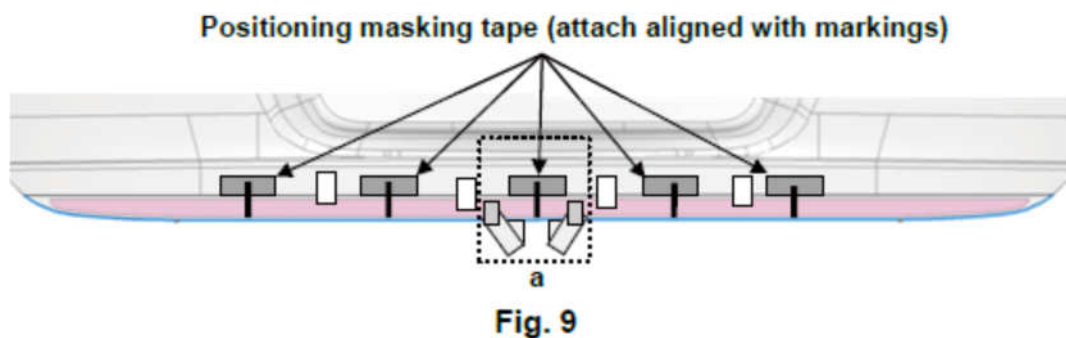

- 6) As shown in Figure 10, securely affix the securing masking tape at three points: at the two ends and at a point somewhat to the left of the center.
After confirming that it has been securely affixed, peel off the masking tape used to temporarily hold the garnish in place (4 locations).

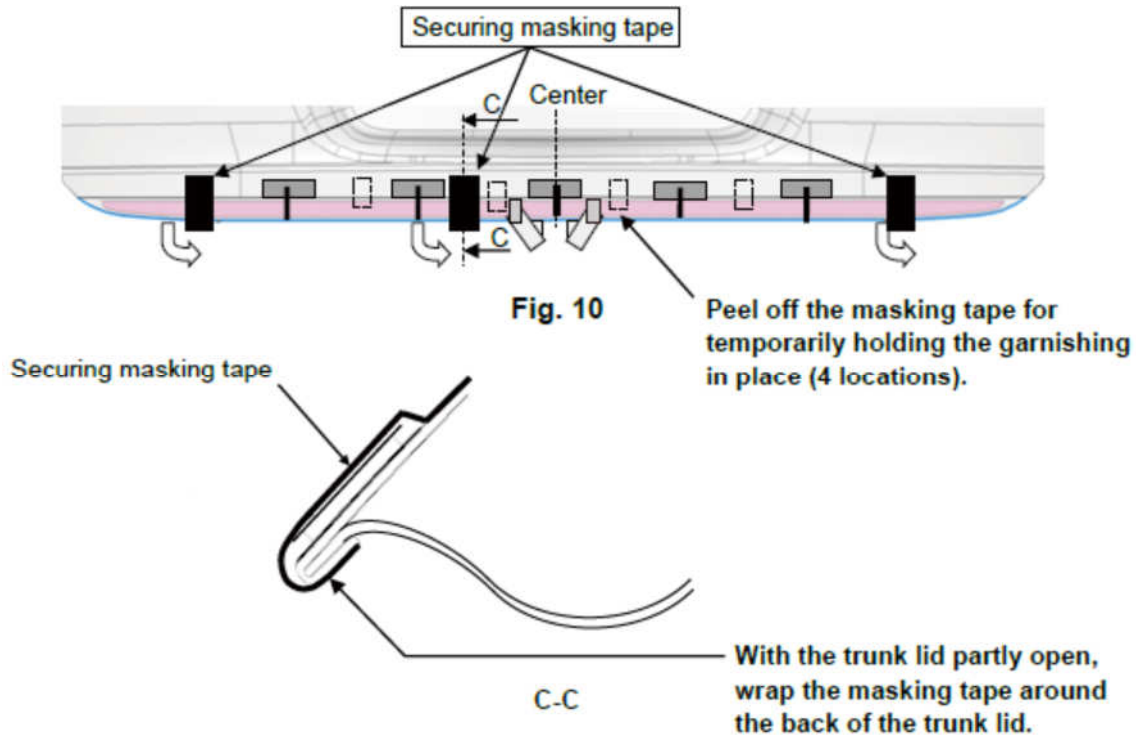

(3) Attaching the garnish

- 1) Attach the garnish starting from the center and working to the right.

As shown in Figure 11, attach the trunk lid garnish by peeling off the release liner, starting from the center and then working to the right.

Keeping a constant distance between the trunk lid garnish and the bottom edge of the trunk lid, attach the garnish, without pulling on it, using the markings for reference.

Continue to attach the trunk lid garnish, peeling off the securing masking tape along the way.

- 2) For the left side, attach the garnish in the same way as for the right side, starting from the center and working to the left.

- 3) Close the trunk lid and, after firmly pressing the trunk lid garnish along its entire length, remove the positioning masking tape (5 locations) and application tape to complete the application process.

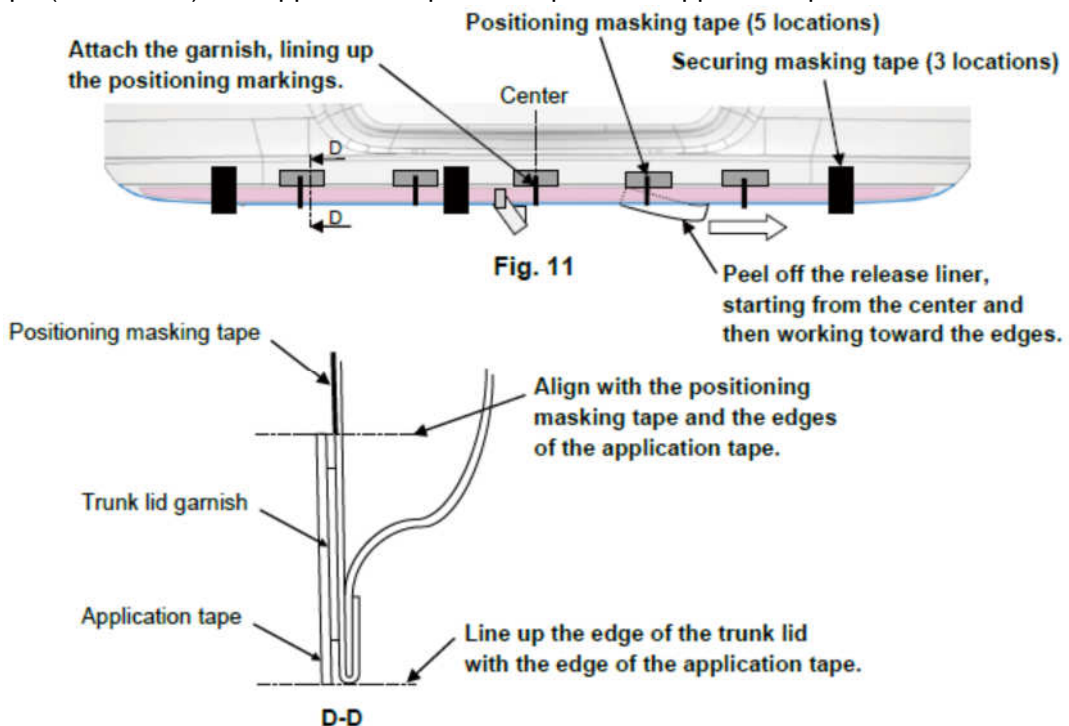

* Advice

- * When peeling off the release liner and the securing masking tape, take care not to lift and bend the trunk lid garnish itself.
- * If there are any gaps between the trunk lid garnish and surface of the vehicle to which it is attached, rainwater or other water may seep into the area, resulting in peeling.
Press and attach the garnish securely so that there are no gaps.
- * Attempting to peel off and reapply trunk lid garnish after it has been attached may result in wrinkling or cracking, so take special care if attempting to do so.