





Installation and Operations instructions for Flexible Draw Stiffener Front

- Thank you for purchasing this product.
- This manual provides installation and handling instructions for this product, and precautions to be observed.
- Before using this product, be sure to read "Safety Precautions" and use the product properly.
- Keep this manual in a safe place, such as the glove box, and refer to it whenever necessary.

Important precautions are indicated with the following marks. Be sure to observe those precautions.

 Warning	Precautions that you must observe for your safety. [Failure to observe these precautions may result in death or serious injury.]
 Caution	Precautions that you must observe for your safety and for your vehicle. [Failure to observe these precautions may result in damages or accidents.]
* Advice	Information that you should familiarize yourself with. Information that are useful.

WARNING

- Never attempt to modify this product. This may damage the product and may become cause of serious accidents.
- Be sure to stop the engine during work for safety reasons.
- Be sure to tighten bolts and nuts firmly.
- Inspect the nuts and bolts after the first 60 miles (100 km) of driving after attaching them. Re-tighten them if necessary.
- If abnormal noise or vibration occurs while driving, pull over the car immediately to a safe place, and then inspect and re-tighten the attaching bolts. If abnormalities persist, perform inspection and make necessary repairs immediately.
- If you continue to drive in this condition, damages or accidents may occur.
- Stop using this product immediately if it has defects such as deterioration and breakage, or receives a strong impact, as these conditions impair the product's original performance.
- Make sure that no part comes in contact with the battery while working.

Caution

- This product does not improve the limit performance significantly. Always drive safely.
- Do not use this product on inapplicable vehicles or for purposes other than it is designed for. Doing so may result in damages or accidents.
- Install this product in accordance with the service manual issued by SUBARU CORPORATION for your model. Also make sure to adhere to the precautions described in this document.
- If bolts and nuts are not tightened with specified torque while installing this product, they may be damaged or become loose. Make sure to tighten them with the specified torque.
- After installing this product, the fluid should be replenished or changed at a SUBARU dealer.

***Advice**

- SUBARU shall not be held liable for any direct or indirect damage due to failures or other malfunction caused by incorrect installation or handling of this product.
- SUBARU does not honor warranty claims for malfunctions of products or vehicles that occur directly or indirectly due to the installation of this product.
- Malfunctions of vehicles that could occur due to the installation of this product may not be covered by the SUBARU vehicle warranty.
- When replacing parts with this product, be sure to use genuine SUBARU parts for non-reusable parts, consumables, oil and grease.
- Product specifications are subject to change without notice.
- Installation of this product may cause deterioration in ride comfort or significant changes in driving characteristics.

Installation Instructions

Warning

Link Ball
Do not disassemble.

Stiffener Main Body

Do not disassemble.
Do not tamper with.

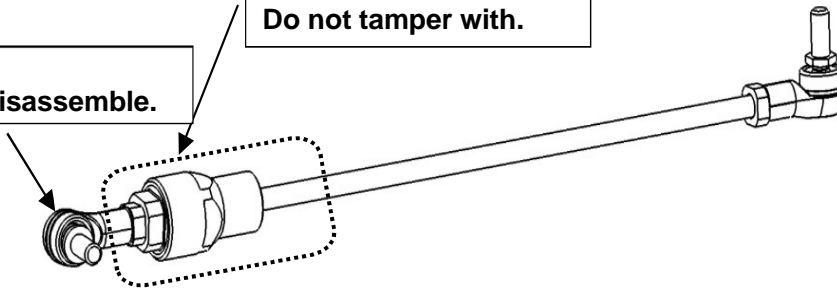

- Do not disassemble the Stiffener's main body, as it has been tightened with the specified torque after the sealant is applied for waterproofing and dustproofing treatment.
- Disassembling it forcibly may result in damage.
- In addition, the connection between the Stiffener's main body and the link ball is torque-controlled before shipping.
- Do not overtighten them or they may be damaged. If you have done so, replace the part with a new one.

1. Part Number and Applicable Car Model

Part Number	Part Name	Applicable Car Model
SG920VA000	STI F FLEX DRAW STIF	WRX Type A ~

2. Component Parts

	Parts name	Quantity
①	Flexible Draw Stiffener Front	1
②	Bracket Front	1
③	Bracket Rear	1
④	Flange bolts M8x20	2
⑤	Flange nuts M8	4
⑥	Washer M8	2

*Please check the quantities of the component parts first. If there are any missing parts or discrepancies, please contact your dealer.

3. Specification

This STI original sports performance part applies moderate tension between the vehicle body and cross member to prevent the chassis from bending when you drive the vehicle. This results in agile and responsive initial steering, as well as a comfortable ride. The vehicle will boast better grip on all four wheels, improved stability when cornering, and also fast and responsive steering performance.

4. Installation Precautions

Warning

- For safety purposes, always turn off the engine and ignition while operating. And disconnect the negative terminal of the battery before you start working on installation of the product.
- Always tighten bolts and nuts firmly.

 **Caution**

- The contents of this manual is designed for automobile mechanics or those who have basic knowledge about automobile maintenance. Do not let inexperienced persons to work alone, as it could cause the vehicle to undergo dangerous troubles during driving. To install the product properly for it to function as intended, it is recommended to perform the installation procedure at an authorized SUBARU retailer.
- Be sure to perform the work in accordance with the service manual for the relevant model issued by SUBARU CORPORATION. and observe the precautions in this manual.
- Tighten bolts and nuts according to specified torque. If not tightened with specified torque, the bolts and nuts may become damaged or loose.

5. Simultaneous Replacement and Non-reusable Parts

Nuts and bolts must be replaced in accordance with the service manual issued by SUBARU Corporation.

6. Work Procedure

Make sure to follow instructions in the service manual issued by SUBARU CORPORATION for replacement instructions of related detachable parts when installing this kit.

*An example of the right-hand side of the vehicle is shown in this section. The work should be carried out in the same way on the left-hand side.

Overview of an Installed Flexible Draw Stiffener Front

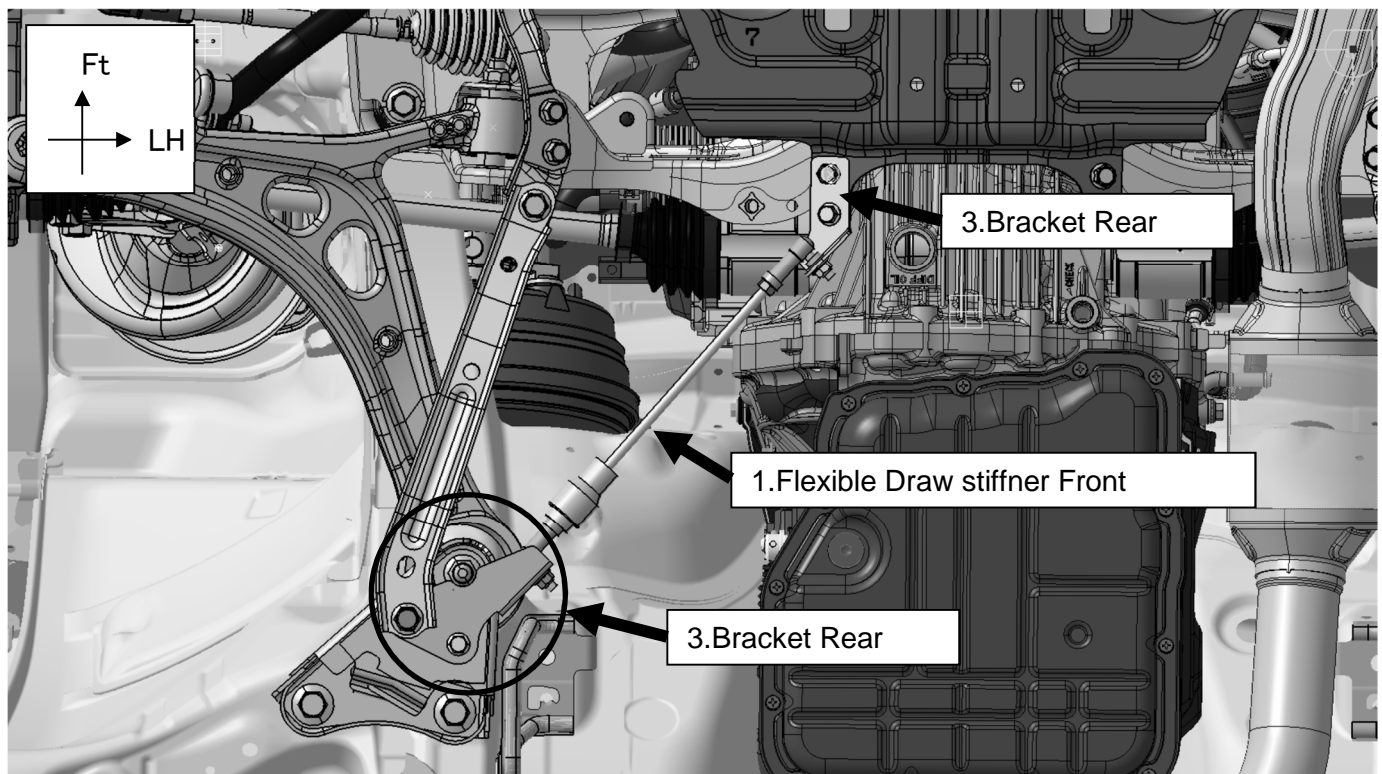

* The above diagram is for reference only and the shape and location of peripheral parts may vary depending on the vehicle specifications.

7: Introduction

1) Prepare the following items

6mm and 12 mm spanners
12 mm thin spanner
12 mm socket
Torque wrench

2) Check the length of the Draw Stiffener.

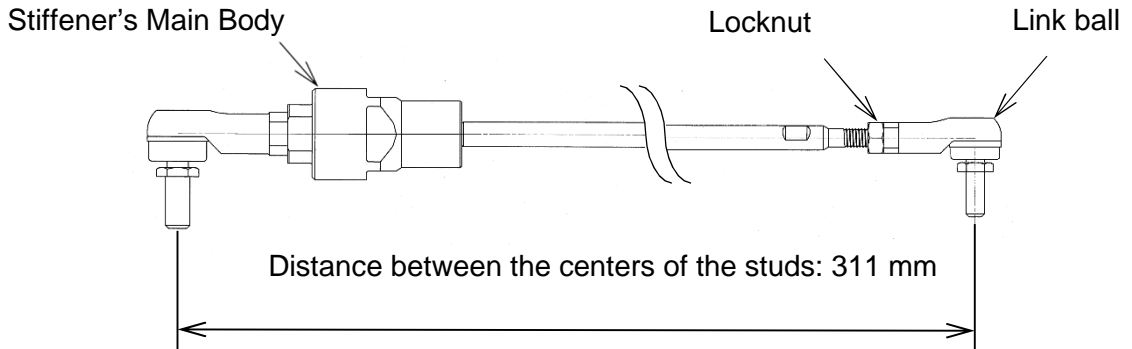

(1) Place a washer between the Draw Stiffener's main body and the bracket, and fix it temporarily.

(2) Tighten the nut.

Warning

- Do not disassemble or retighten the Stiffener's main body. The Stiffener's main body is tightened with the specified torque after applying sealant, so it may be damaged if it is disassembled or retightened. If you have done so, replace the part with a new one.

3) Install the front and rear brackets to the flexible draw stiffener.

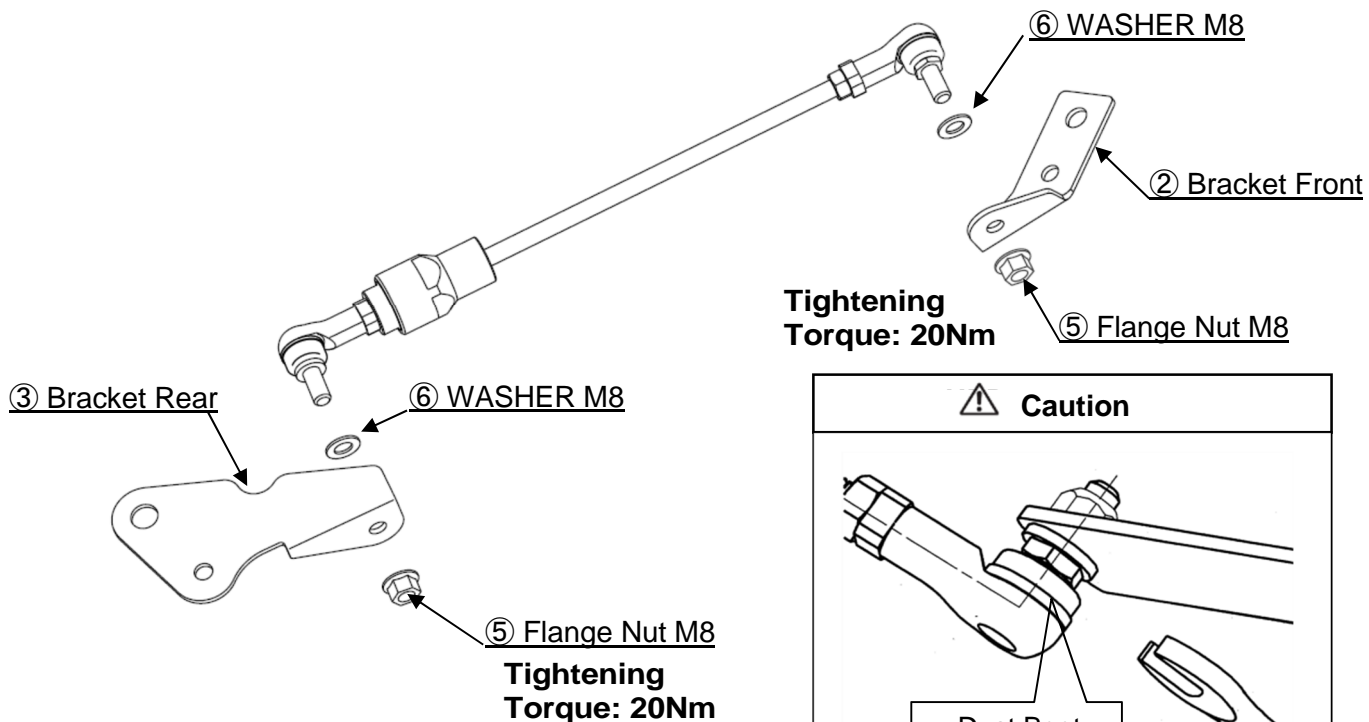

Caution

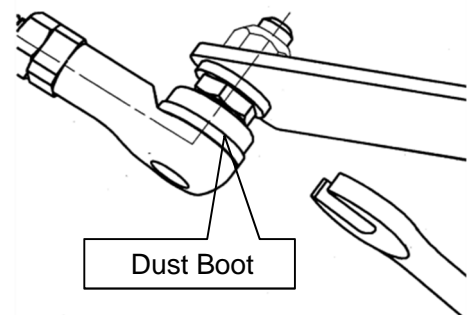

Be careful not to damage the dust boot of the link ball. (grease leakage may happen).

It is recommended to use a thin spanner to prevent biting by the spanner.

Warning

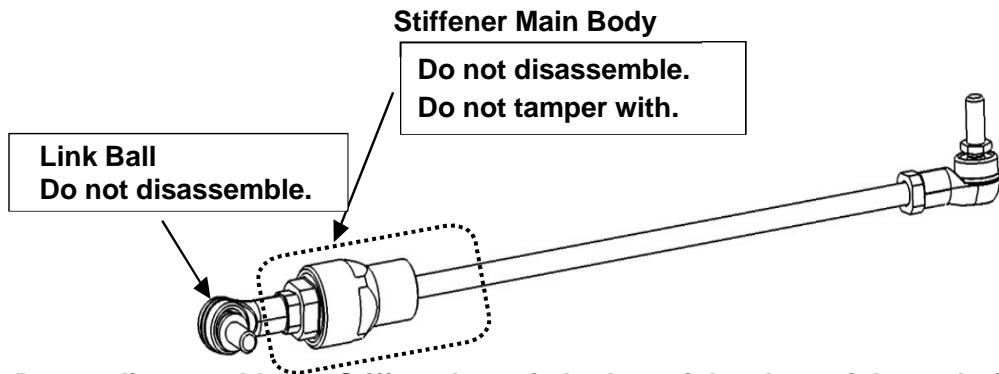

- Do not disassemble the Stiffener's main body, as it has been tightened with the specified torque after the sealant is applied for waterproofing and dustproofing treatment.
- Disassembling it forcibly may result in damage.
- In addition, the connection between the Stiffener's main body and the link ball is torque-controlled before shipping.
- Do not overtighten them or they may be damaged. If you have done so, replace the part with a new one.

8. Installation

- 1) Lift up the vehicle.
- 2) Remove the front support.

This figure shows the RH side

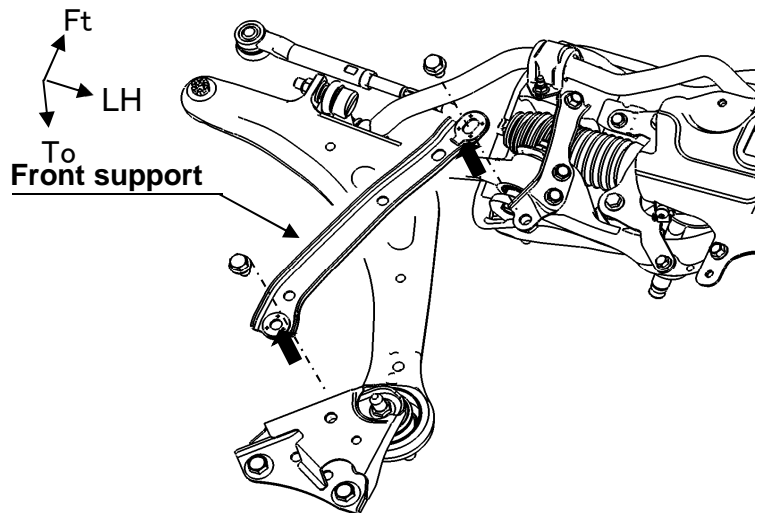

- 3) Install the front bracket of the assembled draw stiffener to the vehicle.

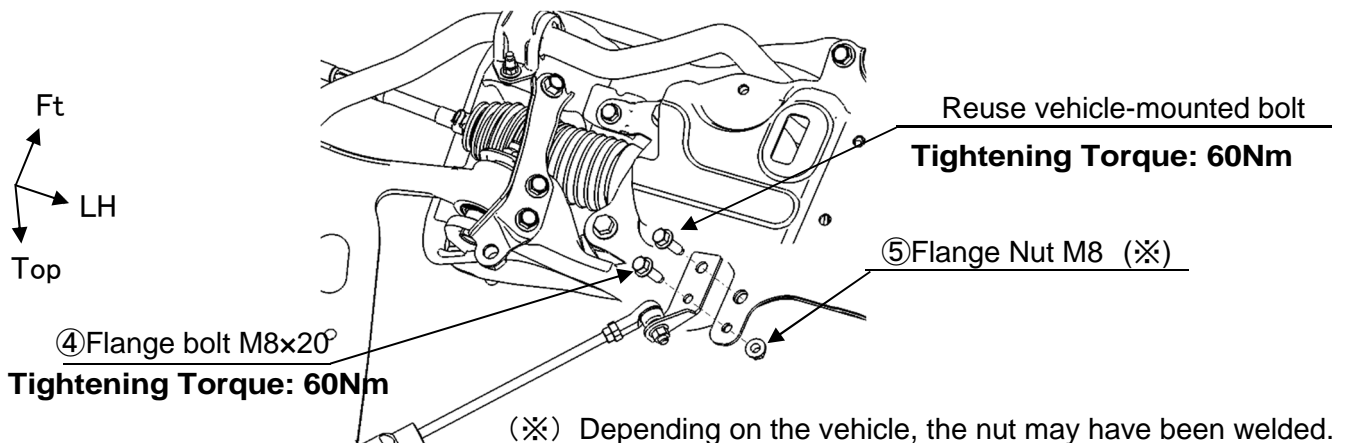

(※) Depending on the vehicle, the nut may have been welded. In that case, use the nut attached to the vehicle.

4) Tighten the bracket rear temporarily with ④ Flange bolt M8 and ⑤ Flange nut M8.

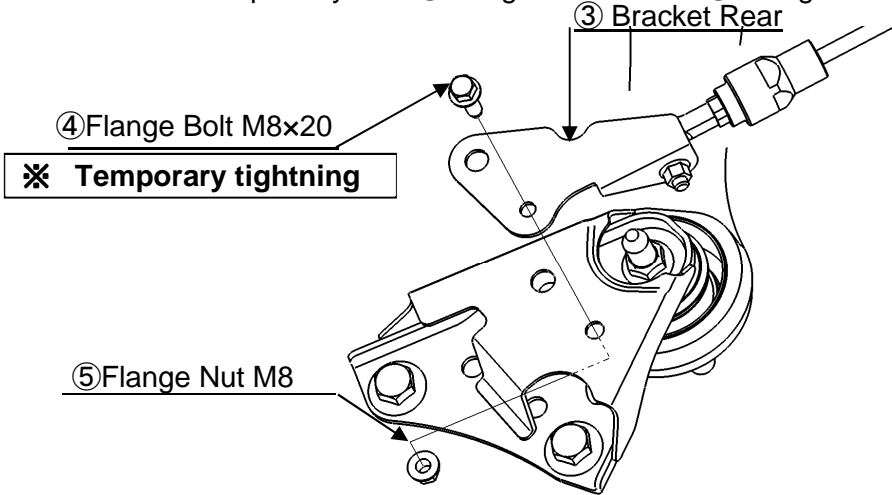
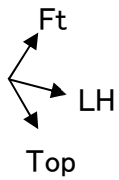

5) Tighten the M12 bolts on the rear bracket together with the support front.

*** Advice**

*If the bolt mounting hole positions are not aligned, adjust the overall length of the flexible draw stiffener.

This figure shows the RH side

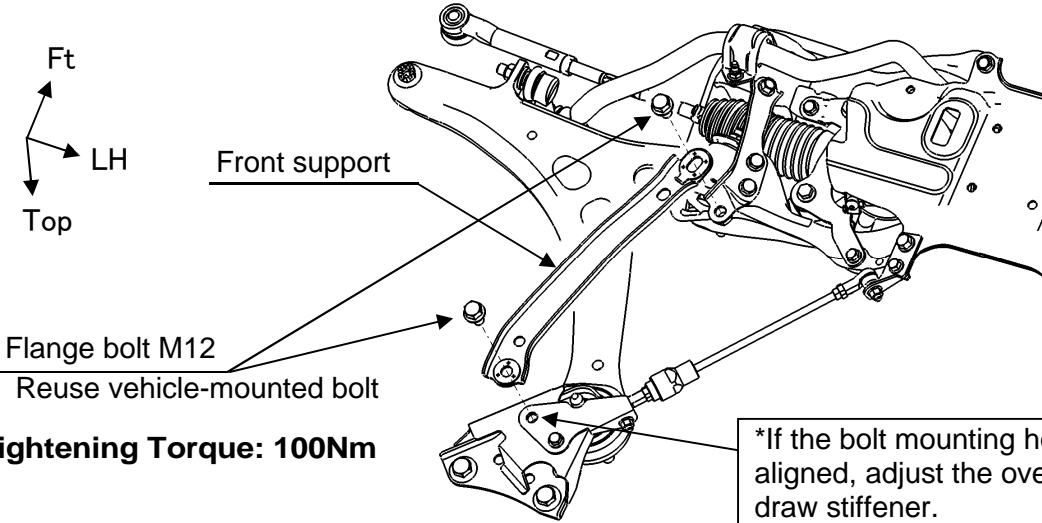
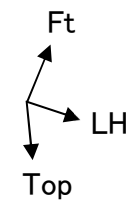

Tightening Torque: 100Nm

Draw stiffener overall length adjustment procedure for hole position

- (1) Loosen the locknut.
- (2) Rotate the rod
- (3) The total length of the flexible draw stiffener changes by rotating the rod.
Adjust the length to match the hole position.

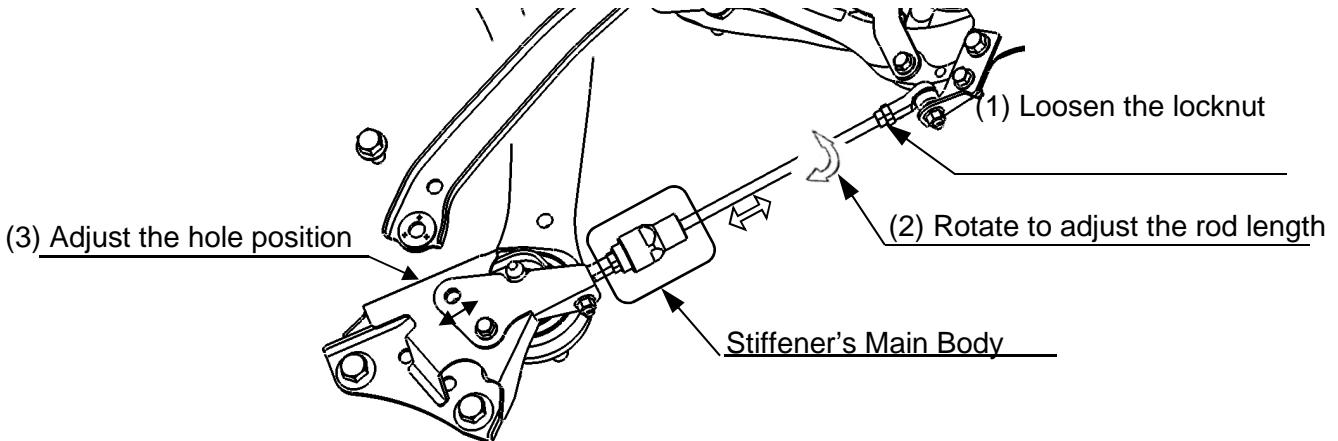

⚠ Warning

- Do not disassemble or retighten the Stiffener's main body.
The Stiffener's main body is tightened with the specified torque after applying sealant, so it may be damaged if it is disassembled or retightened. If you have done so, replace the part with a new one.

6) Tighten the temporary fastened ④ Flange bolt on the ③ Bracket rear.

This figure shows the RH side

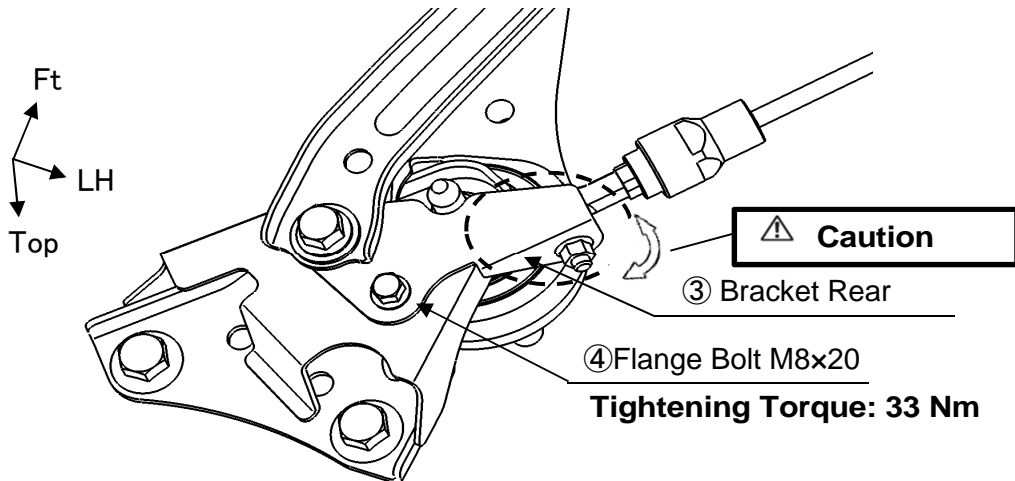

⚠ Warning

- Nuts and bolts must be securely fastened with the specified torque.
If they are not tightened securely, there is a risk of abnormal noise or dislocation.

⚠ Caution

- When retightening the nut that fastens the bracket to the draw stiffener after vehicle installation, be careful not to apply excessive force.

7) Stiffener preload adjustment

- (1) Loosen the locknut while holding the rod down with a spanner to prevent it from turning.
- (2) Rotate the rod (b) to adjust until the adjustment scale position (A) becomes 2,5 – 3mm (0.098-0.118 in).

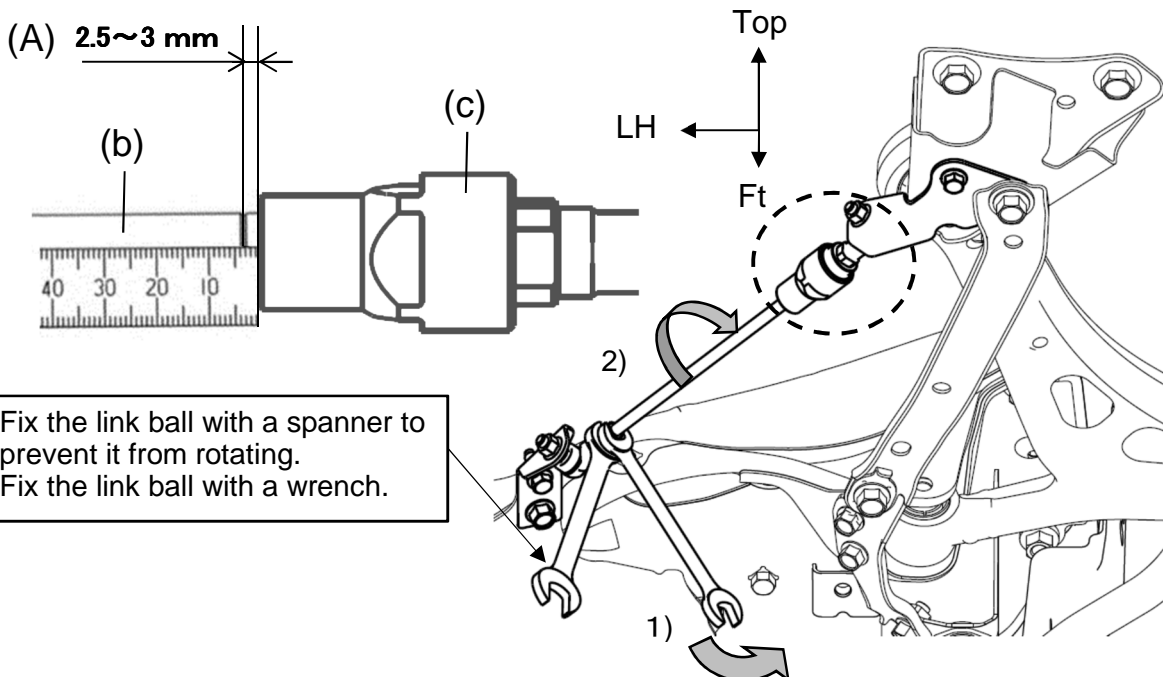

⚠ Caution

- Do not apply any other adjustment value than the specified one for the distance between the Stiffener end face and the rod groove.
- Forced adjustments may not only deteriorate the performance of the product, but may also damage this product and the vehicle.

(3) Check that the exposed length (B) of the threaded portion for adjustment is in a range from 1 to 14mm (0.039 to 0.551 in).

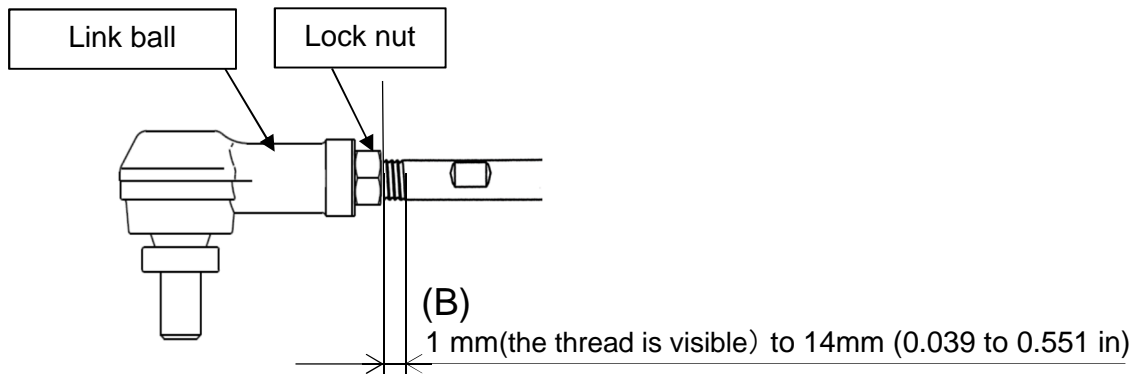

⚠ Caution

- If the exposed length (B) of the threaded portion for adjustment is not within specification, re-adjust the adjustment scale position. Using with the values exceeding the specification may damage the threaded portion

8) Use a spanner to avoid putting a load on the link ball and tighten the locknut with the specified torque.

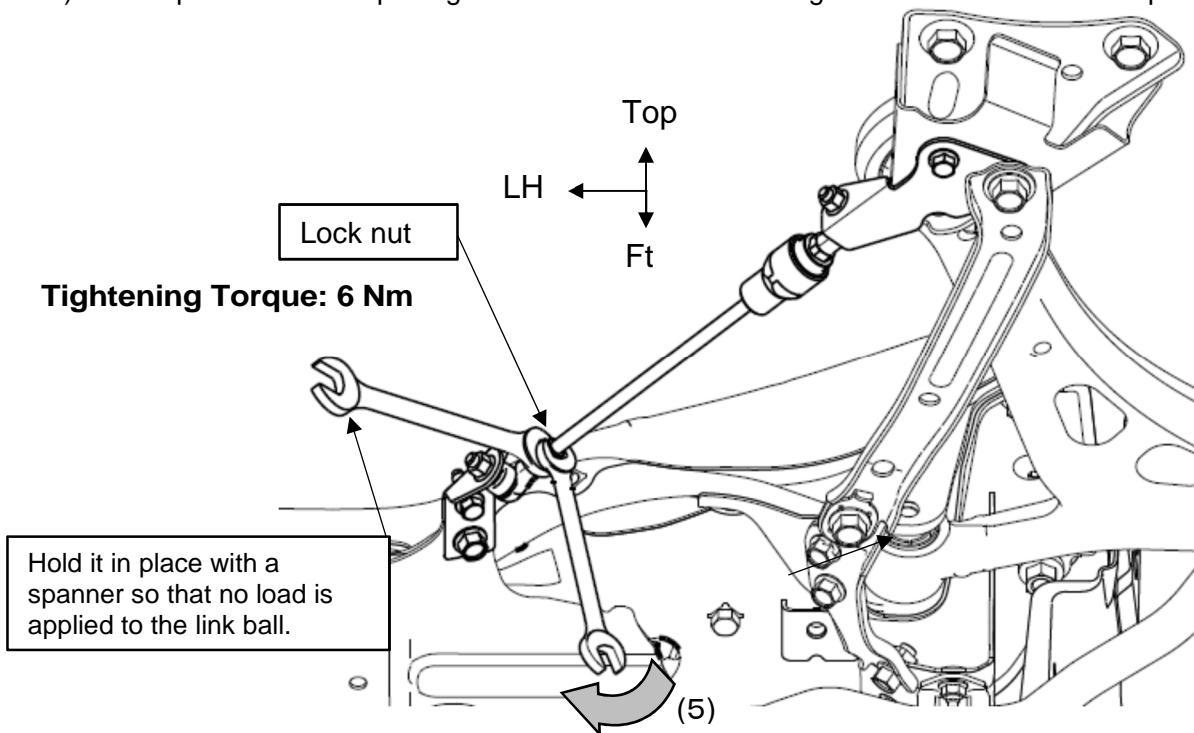

⚠ WARNING

- Nuts and bolts must be securely fastened with the specified torque. If they are not tightened securely, noise may be generated or driving conditions may become unstable, which could result in an accident.

9) Lower the vehicle.

9. Removal

- 1) Lift up the vehicle.
- 2) Loosen the lock nut (a).

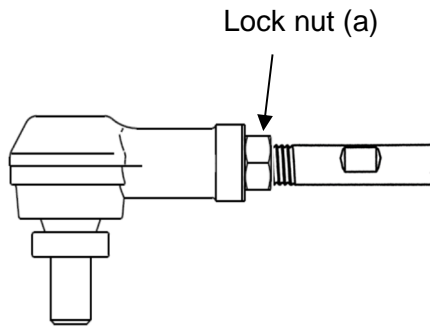

- 3) Rotate the rod (b) to adjust until the adjustment scale position (A) becomes 0 mm.

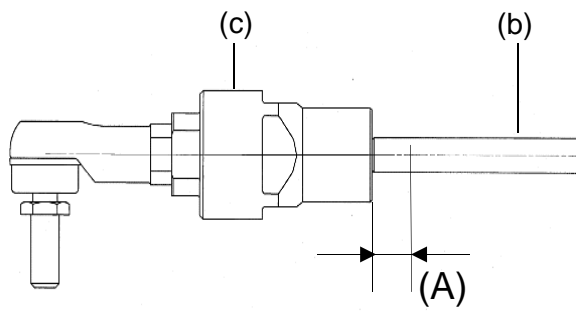

- 4) Follow the reverse procedure for installation.

To customers

Handling Precautions

Warning

- If abnormal noise or vibration occurs while driving, pull over the car immediately to a safe place, and then inspect and re-tighten the attaching bolts. If abnormalities persist, perform inspection and make necessary repairs immediately. If you continue to drive in this condition, damages or accidents may occur.
- Inspect the nuts and bolts after the first 60 miles (100 km) of driving and periodically after attaching them. Re-tighten them if necessary.
- Please do not use this product for other than applicable models.
- this product makes the movement of the vehicle sharper with respect to the input from the road surface and the input from the steering, but it does not dramatically improve the limit performance itself. Please try to drive safely as before the replacement.

Caution

- We recommend that this product be installed at an authorized Subaru maintenance facility to ensure proper installation and function.
- When removing the flexible tower bar from the vehicle, place the support on the under side of the bar so that the center part (rubber boot) does not bend.
- Do not remove the rubber boot from the center spherical bearing.
- Installation of this product may cause deterioration of ride comfort and major changes in driving characteristics.