



SUBARU

INSTALLATION INSTRUCTIONS

PART NUMBER: PS938-42190-XX

DESCRIPTION: BODY SIDE MOLDING KIT

PRE-INSTALLATION NOTES:

- Care must be taken when installing this accessory to ensure damage does not occur to the vehicle. The installation of this accessory should follow approved guidelines to ensure a quality installation.

KIT CONTENTS:

Body Side Molding Passenger Side FR – 1X

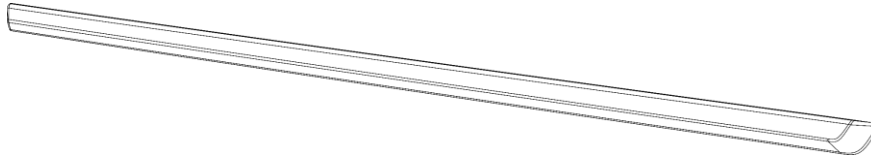

Body Side Molding Passenger Side RR – 1X



Body Side Molding Driver Side FR – 1X

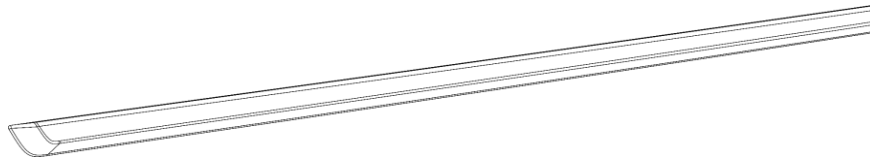

Body Side Molding Driver Side RR – 1X

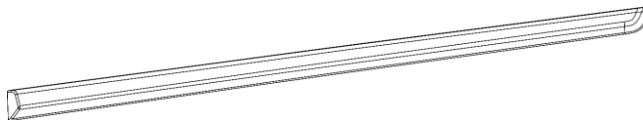

TOOLS REQUIRED:



Masking Tape – 1” wide



Cleaner



Clean Lint-Free Cloths

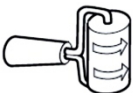

Rubber Roller - 1” to 3” wide

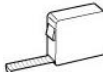

Flexible Scale or Tape Measure



Non-marring straight edge

DESCRIPTION
BODY SIDE MOLDING KIT

ISSUE
01

DATE
22/04/04

SUBARU OF AMERICA

PAGE
1 / 5



SUBARU

INSTALLATION INSTRUCTIONS

PART NUMBER: PS938-42190-XX

DESCRIPTION: BODY SIDE MOLDING KIT

1



ENSURE VEHICLE IS CLEAN AND PREPPED FOR INSTALL.



ENSURE DOOR SURFACE TEMPERATURE IS BETWEEN 60°F (16°C) TO 90°F (32°C).



SATURATE AND CLEAN AREA USING A LINT FREE CLOTH.



WIPE THE CLEANED SURFACE WITH A DRY LINT-FREE CLOTH.

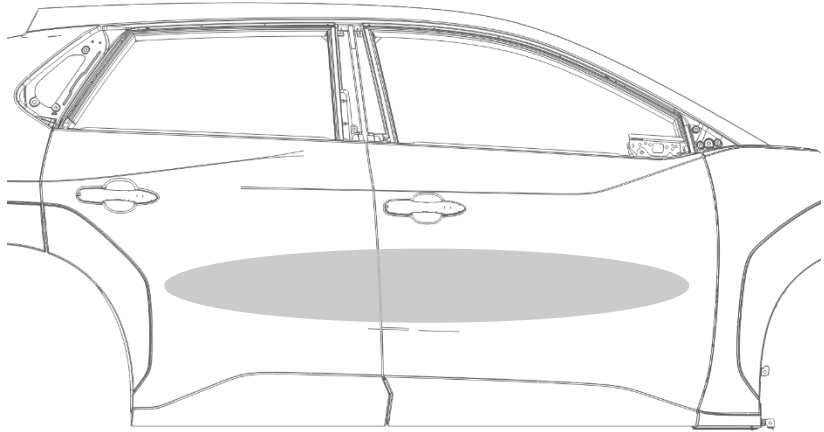

2

LOCATE THE HORIZONTAL MEASUREMENT LOCATION ON THE FRONT CLADDING.

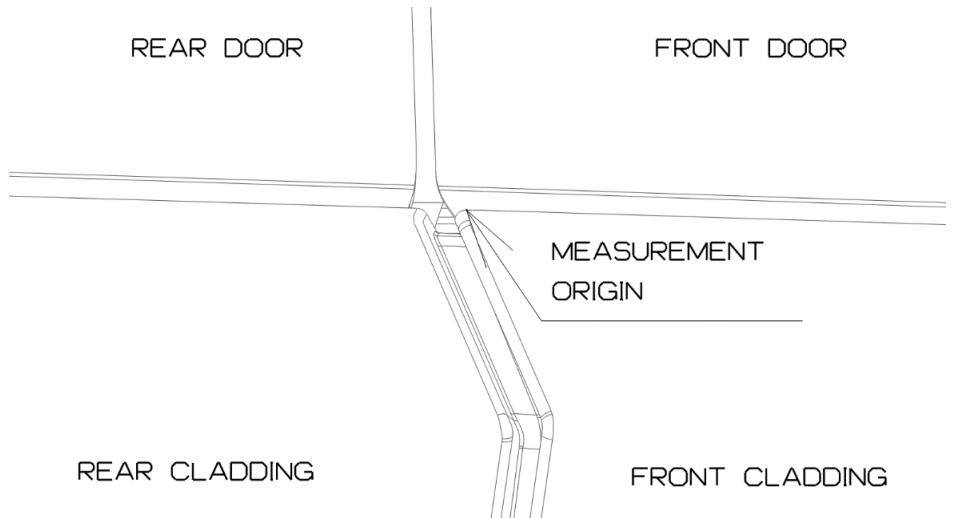

3

FRONT DOOR

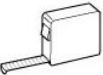

MEASURE THE LOCATIONS ALONG THE UPPER EDGE OF THE FRONT CLADDING, THEN MEASURE THE VERTICAL LOCATIONS FOR THE FRONT MOLDING.



FOR EACH VERTICAL LOCATION, PLACE A PIECE OF TAPE ON THE FRONT DOOR.

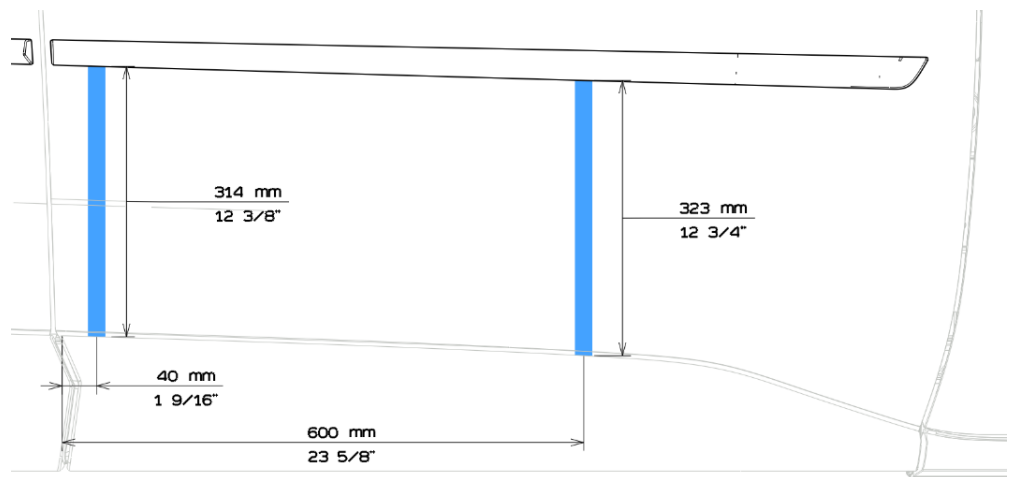

DESCRIPTION
BODY SIDE MOLDING KIT

ISSUE
01

DATE
22/04/04

SUBARU OF AMERICA

PAGE
2 / 5



SUBARU

INSTALLATION INSTRUCTIONS

PART NUMBER: PS938-42190-XX

DESCRIPTION: BODY SIDE MOLDING KIT

4 REAR DOOR

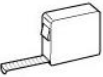

MEASURE THE LOCATIONS ALONG THE UPPER EDGE OF THE REAR CLADDING, THEN MEASURE THE VERTICAL LOCATIONS FOR THE REAR MOLDING.



FOR EACH VERTICAL LOCATION, PLACE A VERTICAL PIECE OF TAPE ON THE REAR DOOR.

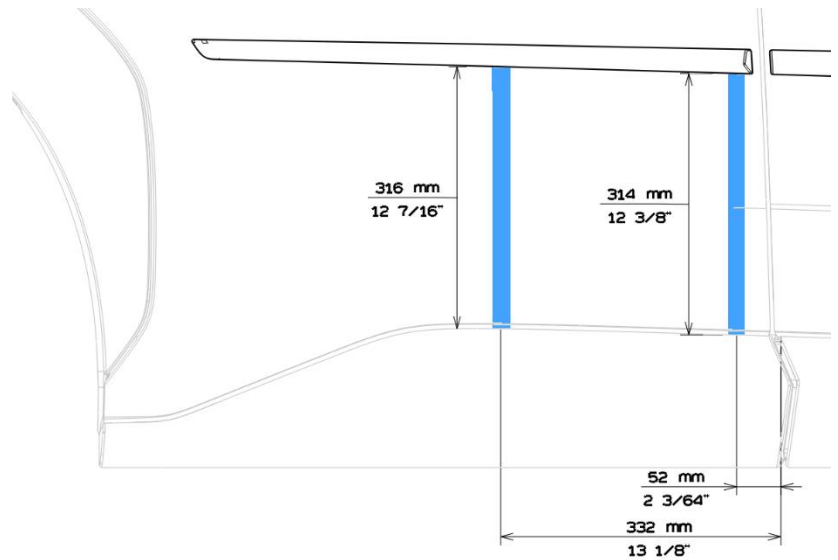

5

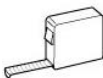

MEASURE THE DISTANCE FROM THE EDGE OF THE FRONT DOOR TO THE EDGE OF THE FRONT MOLDING.



USING A PIECE OF TAPE, MARK THE LOCATION OF THE FRONT MOLDING FROM THE EDGE OF THE FRONT DOOR.

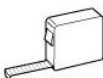

MEASURE THE DISTANCE FROM THE EDGE OF THE REAR DOOR TO THE EDGE OF THE REAR MOLDING.



USING A PIECE OF TAPE, MARK THE LOCATION OF THE REAR MOLDING FROM THE EDGE OF THE REAR DOOR.

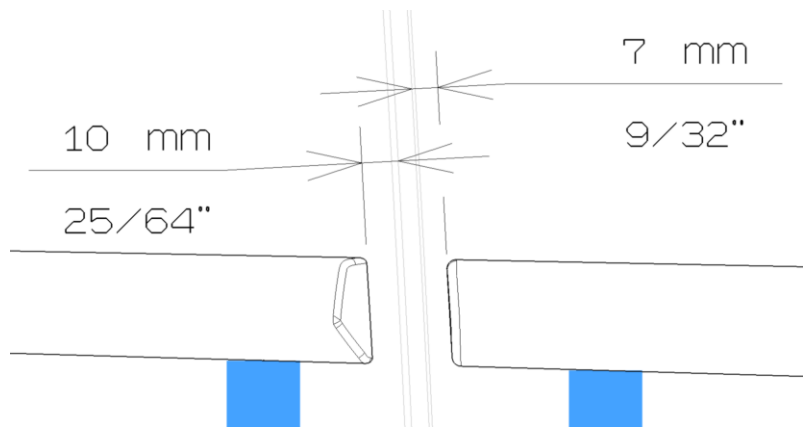

6

APPLY A HORIZONTAL STRIP OF TAPE BRIDGING THE FRONT AND REAR DOOR GAP.



HORIZONTAL TAPE STRIP

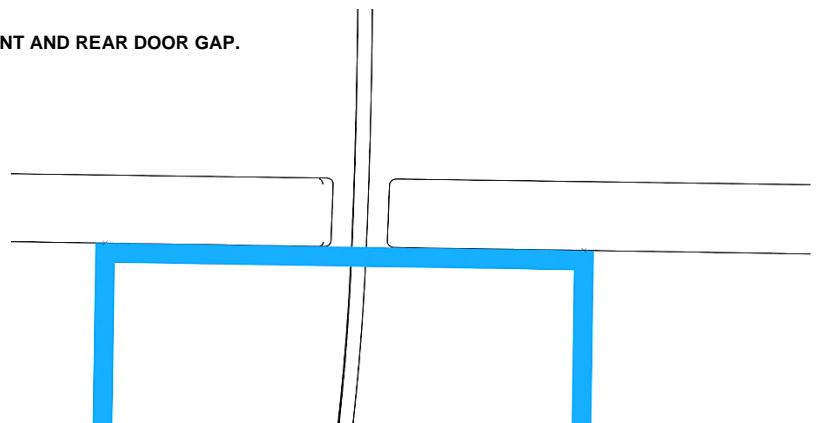



SUBARU

INSTALLATION INSTRUCTIONS

PART NUMBER: PS938-42190-XX

DESCRIPTION: BODY SIDE MOLDING KIT

7

FOR EACH MOLDING, CAREFULLY FOLD THE LINER TABS AWAY FROM THE MOLDING SUCH THAT THE TABS ARE ACCESSIBLE WHEN THE MOLDING IS IN INSTALL POSITION.

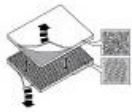

PEEL THE LINER

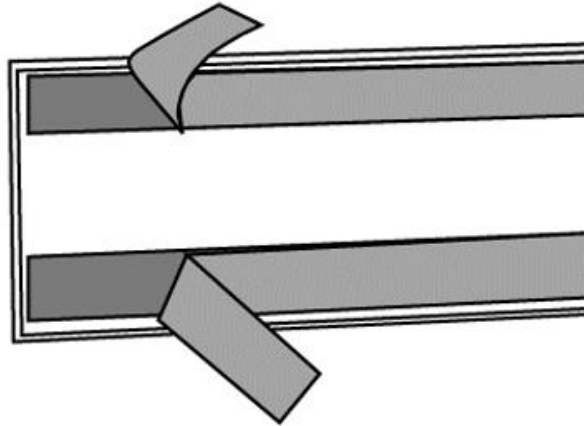

8

CAREFULLY HOLDING THE REAR MOLDING, ALIGN THE MOLDING ON THE MARKED LOCATIONS. BEGIN TO PEEL AWAY THE LINER BEGINNING FROM THE MIDDLE OF THE VEHICLE.

REPEAT FOR THE FRONT MOLDING.

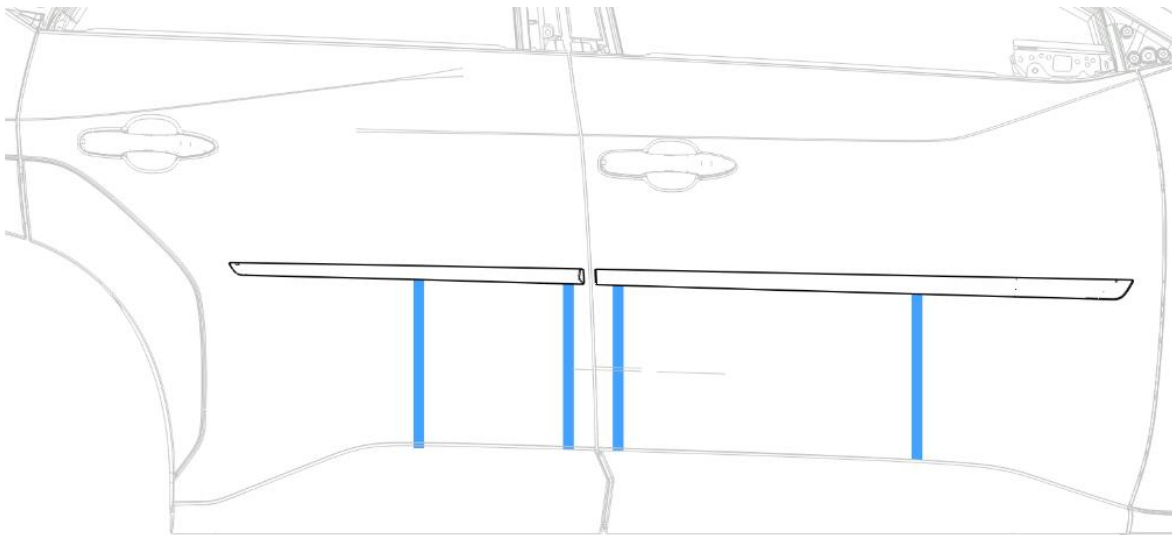



SUBARU

INSTALLATION INSTRUCTIONS

PART NUMBER: PS938-42190-XX

DESCRIPTION: BODY SIDE MOLDING KIT

9

CHECK THE ALIGNMENT BETWEEN THE MOLDINGS BY PLACING A NON-MARRING STRAIGHT EDGE FLUSH WITH THE BOTTOM OF THE FRONT AND REAR MOLDINGS. THE EDGES MUST ALIGN.



NON-MARRING
STRAIGHT EDGE

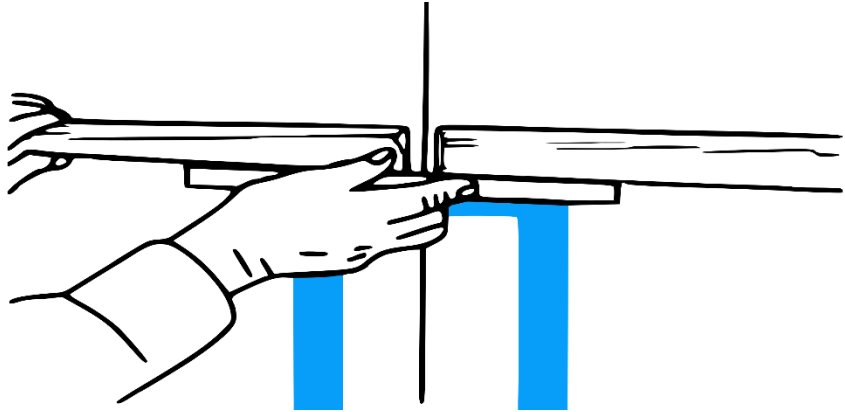

10

USE A HAND ROLLER TO ROLL OVER THE MOLDINGS WHILE APPLYING 15 LBS OF FORCE TO ENSURE COMPLETE ADHESION OF TAPE TO THE DOOR SURFACE.

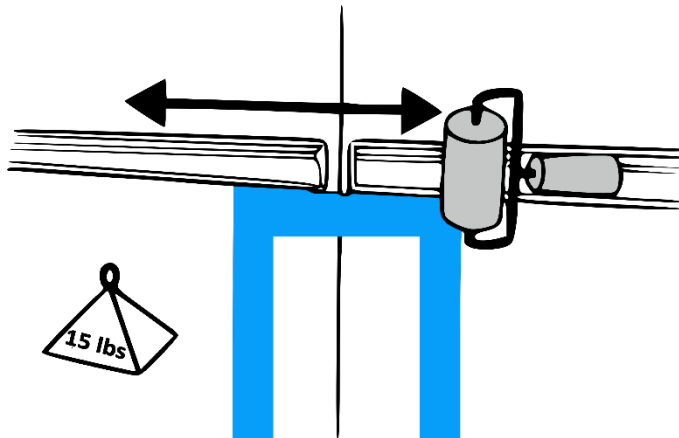

DESCRIPTION
BODY SIDE MOLDING KIT

ISSUE
01

DATE
22/04/04

SUBARU OF AMERICA

PAGE
5 / 5