



SUBARU

Part number:
Numéro de pièce:
Vehicle:
Véhicule:

J201SXC100
2024 ASCENT

Installation instructions
Instructions d'installaiion

Description: Exterior auto dimming mirror with approach lighting
Description: Rétroviseur extérieur à antiéblouissement automatique avec éclairage d'approche

Kit contents

Contenu de la trousse

A

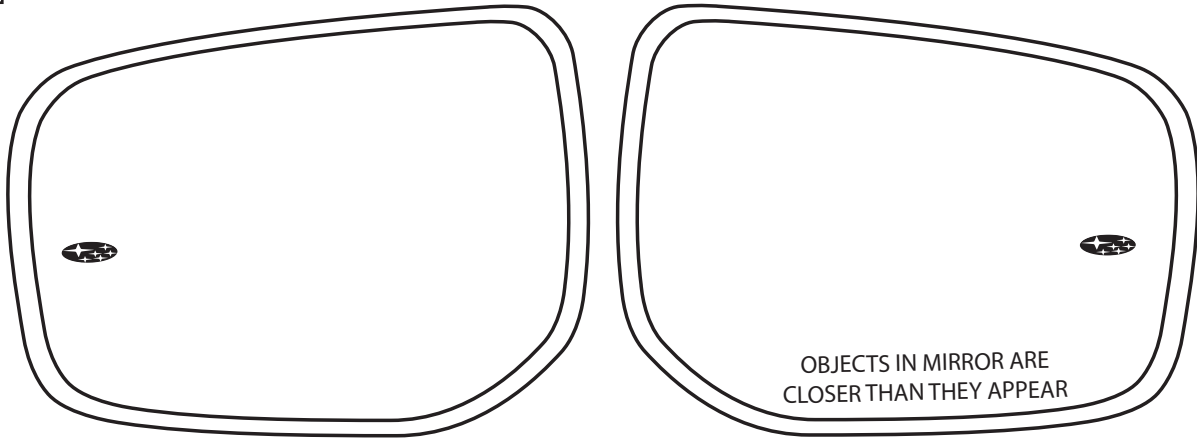

Auto dimming mirror
Tetroviseur antiéblouissement

B

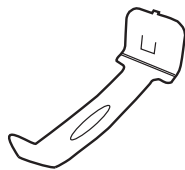

Friction Damper Spring
Ressort amortisseur à friction

2X

Tools required
Outils requis

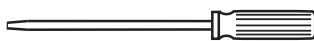

10 mm



12 mm

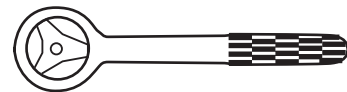

PART NUMBER
J201SXC100

ISSUE
A

DATE
6/7/2023

SUBARU OF AMERICA

PAGE
1/5

1 

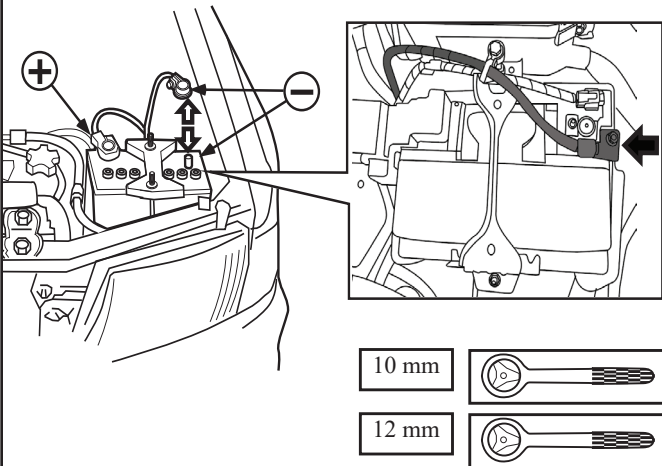

10 mm 

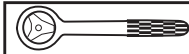
12 mm 

Disconnect battery. If equipped disconnect eyelet cable only.
Déconnectez la batterie. Si elle en est équipée, déconnectez le câble de l'œillet uniquement.

2 

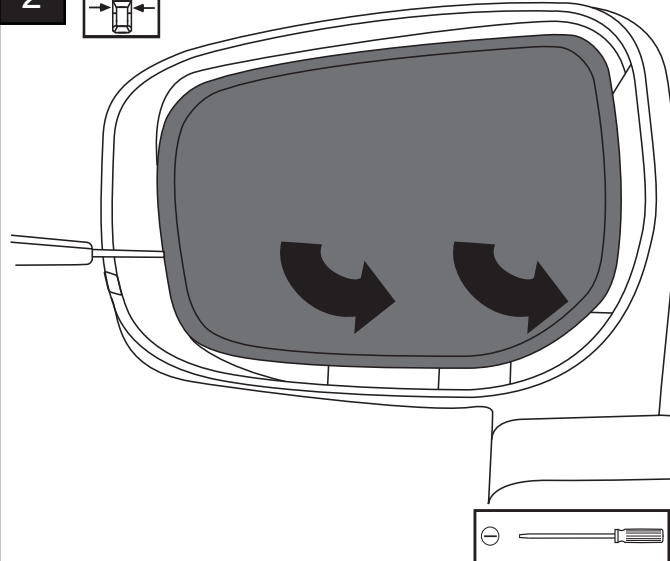

Protect mirror housing to prevent damage. Using screwdriver, remove mirror by disengaging the four mirror clips. Pull straight out to remove. Driver's side shown.
Protéger le boîtier de rétroviseur pour éviter de l'endommager. À l'aide d'un tournevis, retirer le rétroviseur en dégageant les quatre attaches. Tirer dessus directement pour le retirer. Côté du conducteur montré.

3 

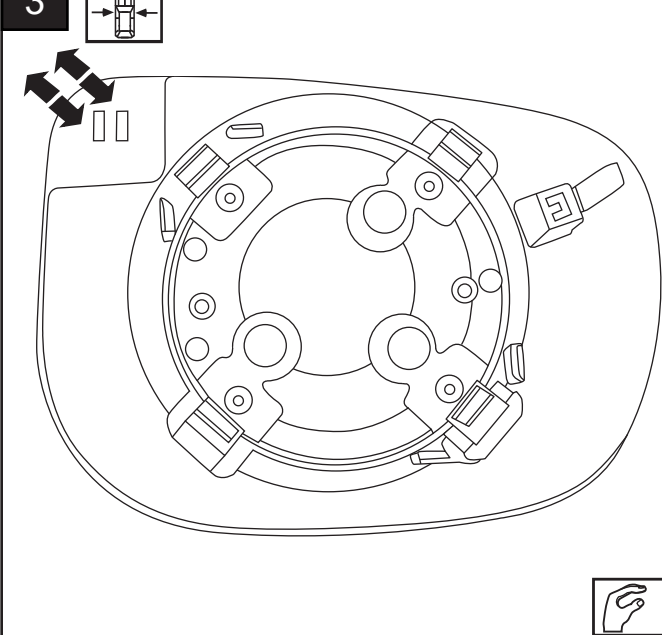

If equipped, disconnect heater connector.
Débranchez les bornes de chauffage, si le véhicule en est équipé.

4 

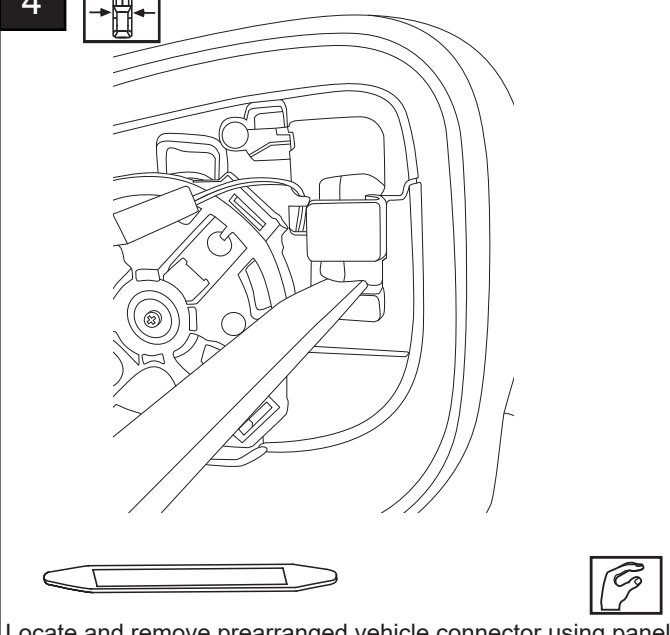

Locate and remove prearranged vehicle connector using panel removal tool. **WARNING** - Do not pull harness wire to retrieve connector.
Repérez connecteur de véhicule prédisposé et retirez-le à l'aide de l'outil de retrait de panneau. **AVERTISSEMENT** - Ne tirez pas sur le faisceau de fil pour récupérer le connecteur.

5

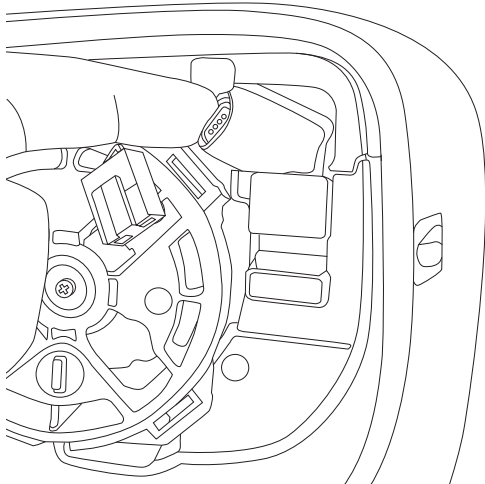

Remove foam from prearranged connectors.
Enlevez la mousse qui couvre les connecteurs prémontés.

6

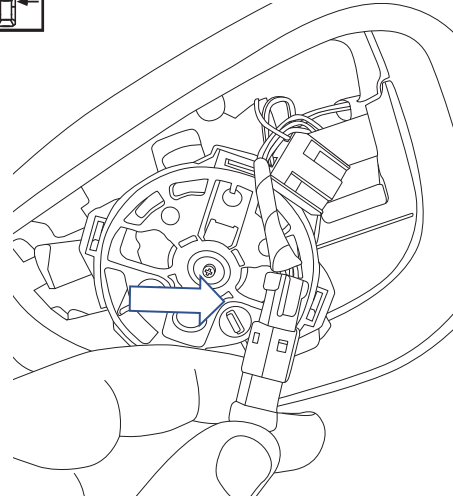

Remove prearranged connector mate (a) by depressing locking tabs. Dispose of connector mate.
Déposez le coupleur de connecteur (a) en appuyant sur les languettes de verrouillage. Mettez le coupleur de connecteur au rebut.

7

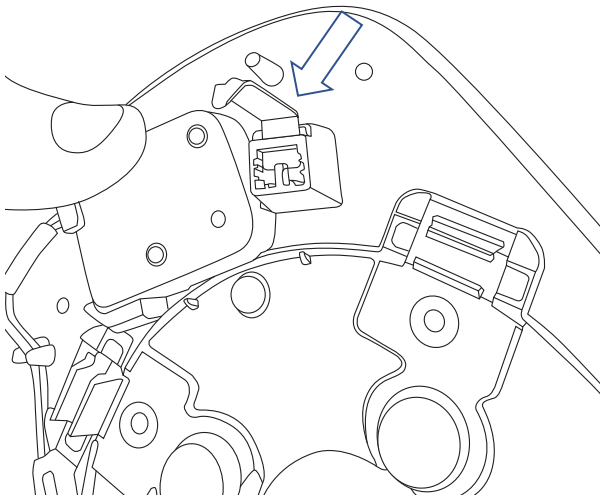

Insert friction damper spring into outboard mirror holder.
Introduisez le ressort de l'amortisseur à friction dans le support du rétroviseur extérieur.

8

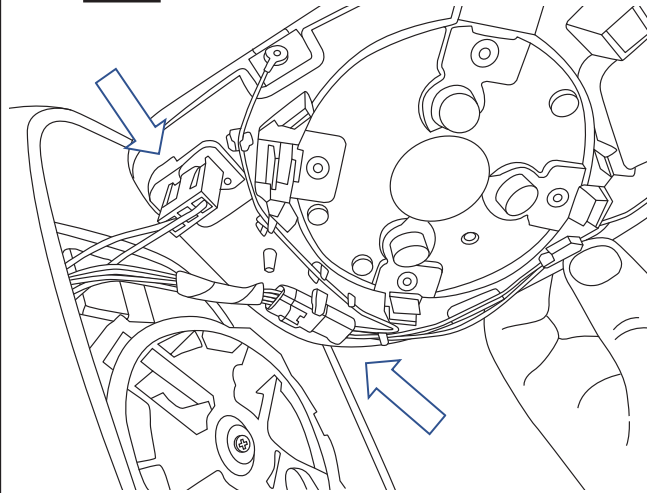

Plug prearranged vehicle connector's into mirror connector's and connect heater connector
Branchez les connecteurs de véhicule prédisposés dans les connecteurs du rétroviseur et branchez le connecteur du dispositif de chauffage.

PART NUMBER
J201SXC100

ISSUE
A

DATE
6/7/2023

SUBARU OF AMERICA

PAGE
3/5

9

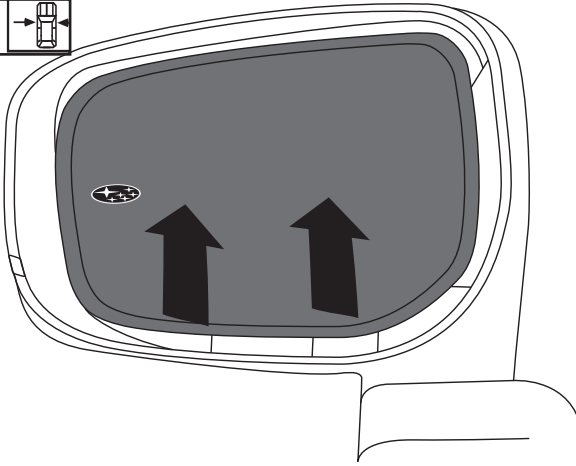

Secure mirror to vehicle motor pack by gently pressing until all four clips are engaged. Ensure friction damper spring inserts correctly into the housing damper pocket. Repeat for passenger's side.

Fixer le rétroviseur au bloc-moteur du véhicule en appuyant doucement dessus jusqu'à ce que les quatre attaches s'enclenchent. Veiller à ce que le ressort amortisseur à friction soit inséré correctement dans le logement de l'amortisseur du boîtier. Répéter la procédure du côté passager.

10

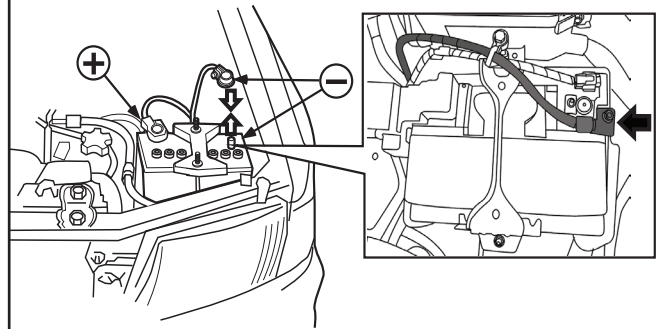

10 mm

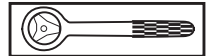

12 mm



Reconnect battery. If equipped reconnect eyelet cable. Tighten bolt to 66 in-lbs.

Rebranchez la batterie. Si elle en est équipée, rebranchez le câble de l'œillet. Serrez les boulons à 66 lb-po.

11

Rear facing sensor
Capteur tourné vers l'arrière.

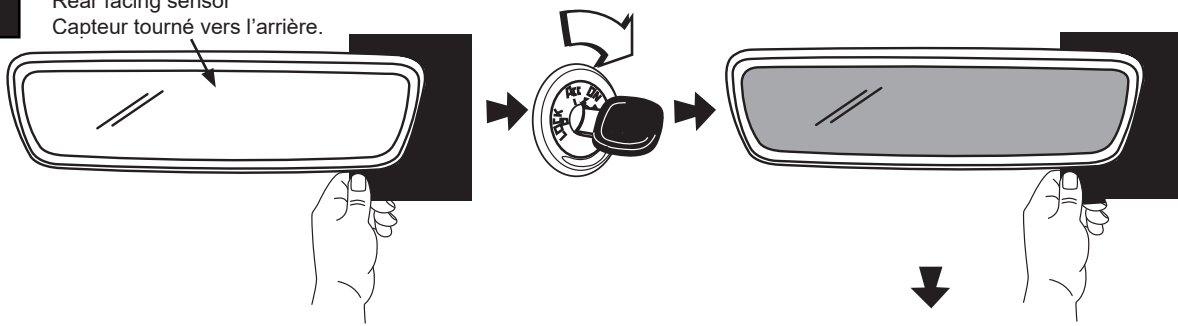

To test the dimming function, cover the forward facing sensor and shine light on the interior mirrors rear facing sensor.
 Pour vérifier la fonction d'assombrissement, couvrir le capteur tourné vers l'avant et éclairer le capteur tourné vers l'arrière des rétroviseurs intérieurs.

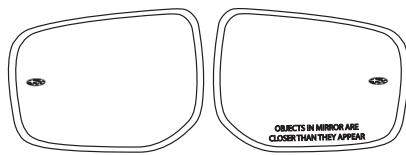
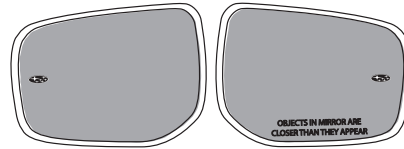

12

