



**SUBARU**

Installation instructions  
Instructions d'installatiion

Part number:  
Numéro de pièce:

J201SSG600

Vehicle:  
Véhicule:

Forester

Description: Exterior auto dimming mirror with blind spot module  
Description: Rétrovisieur extérieur à antiéblouissement automatique avec module d'angle mort

Kit contents

Contenu de la trousse

A

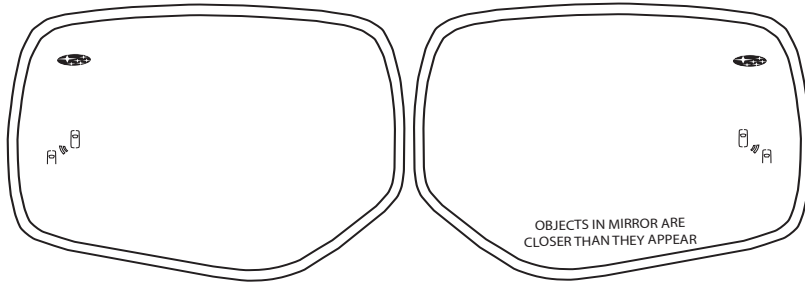

Auto dimming mirror  
Tetrovisieur antiéblouissement

B

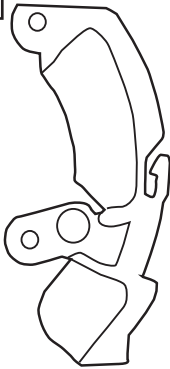

Drive Side  
Friction Damper  
Côté conducteur  
Amortisseur à friction

C



Passenger Side  
Friction Damper  
Côté passager  
Amortisseur à friction

D

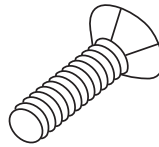

Screw  
Vis

4X

E

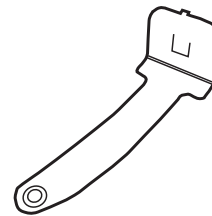

Friction Damper Spring  
Ressort amortisseur à friction

4X

F

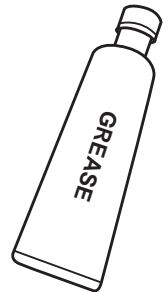

Grease Pack  
Nécessaire de lubrification

Tools required  
Outils requis

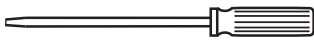

10 mm



12 mm

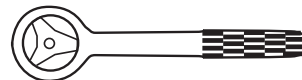

PART NUMBERS  
J201SSG600

ISSUE  
A

DATE  
7/6/16

**SUBARU OF AMERICA**

PAGE  
1/7

**1**

10 mm

12 mm

Disconnect battery. If equipped disconnect eyelet cable only.  
 Déconnectez la batterie. Si elle en est équipée, déconnectez le câble de l'œillet uniquement.

**2**

Using screwdriver, disengage two mirror clips at bottom of mirror. Driver's side shown.  
 À l'aide d'un tournevis, dégagez les deux attaches à la base du rétroviseur. Côté du conducteur montré.

**3**

a

Remove mirror upwards by unhooking from vehicle motor pack (a).  
 Enlevez le rétroviseur en le soulevant et en le débranchant du bloc-moteur (a).

**4**

If equipped, disconnect heater terminals.  
 Débranchez les bornes de chauffage, si le véhicule en est équipé.

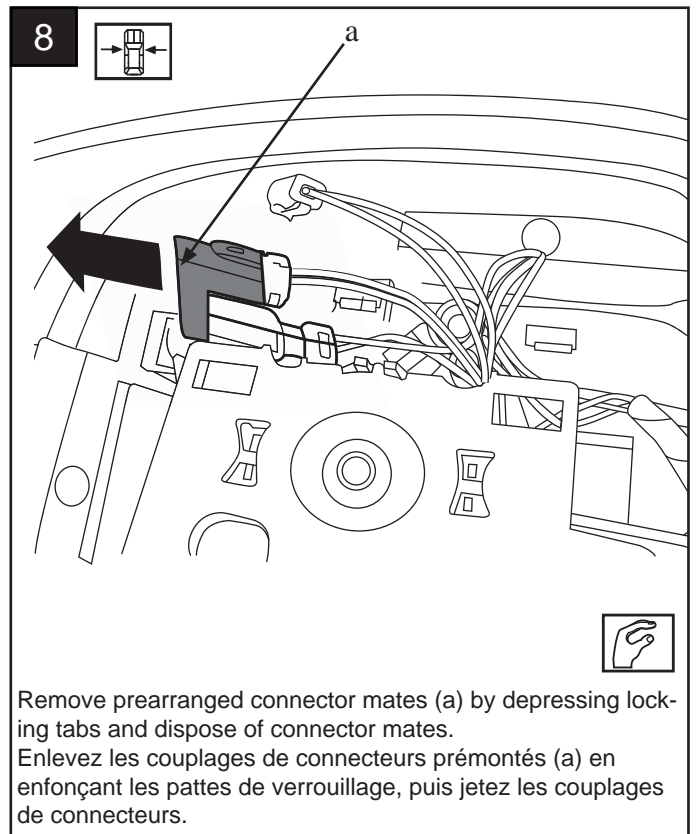
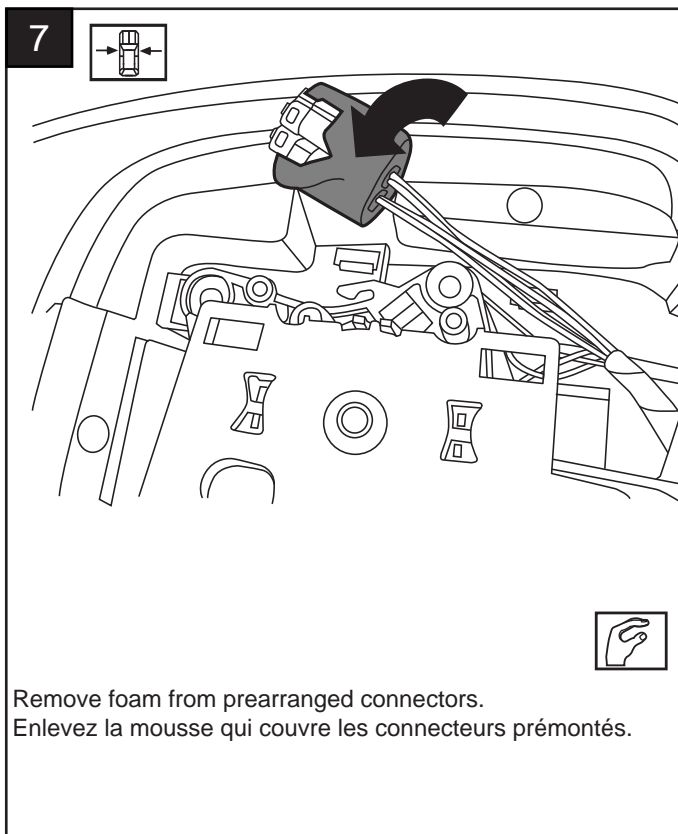
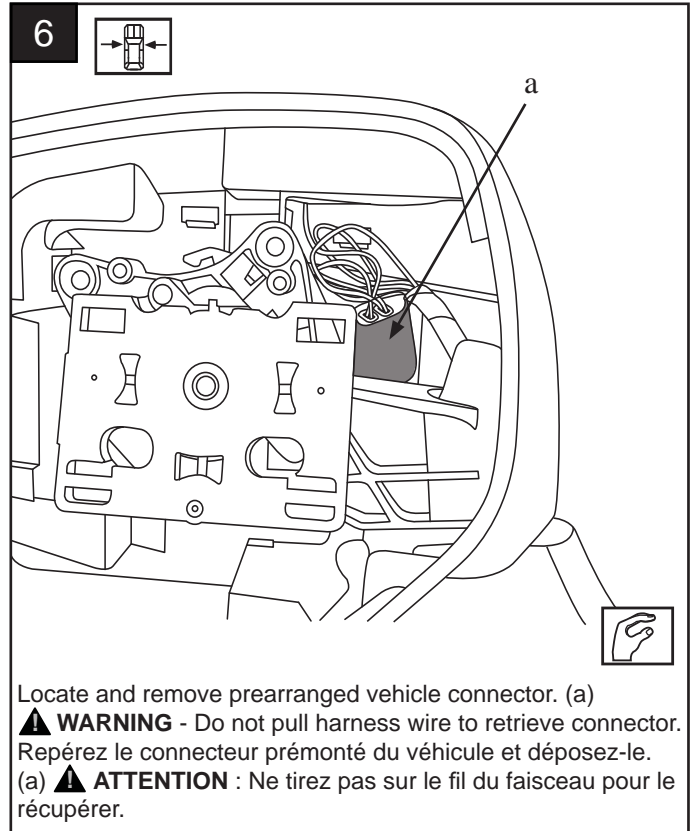
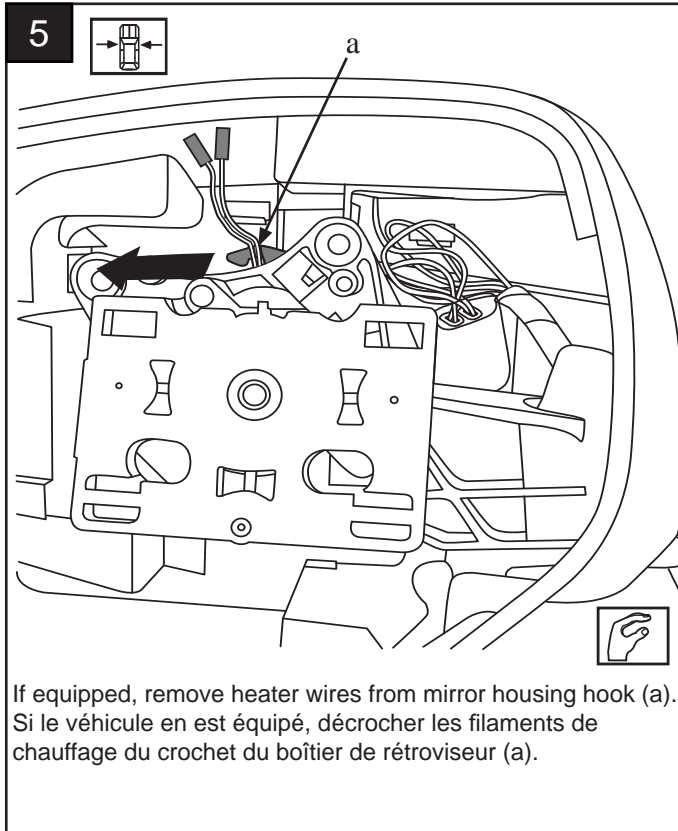

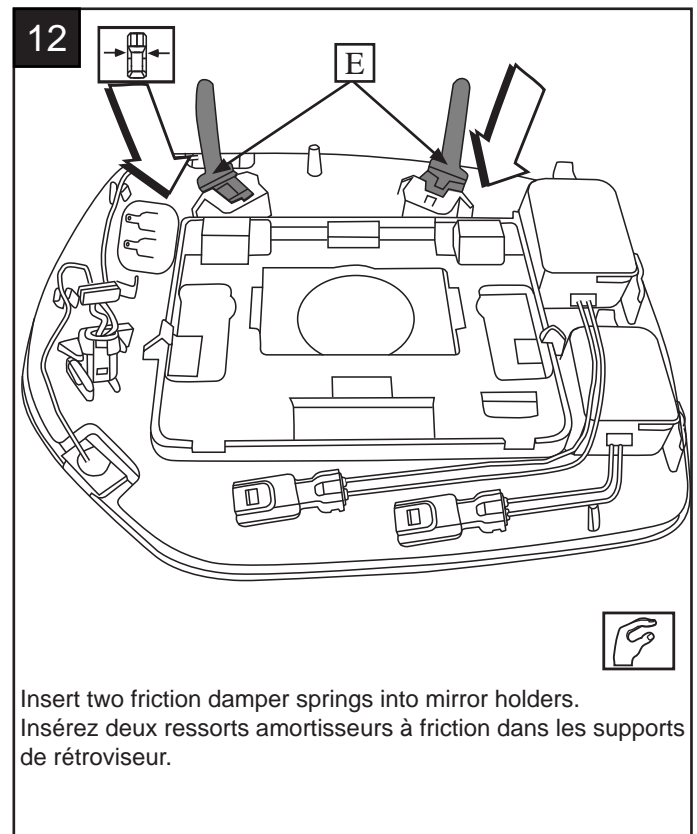
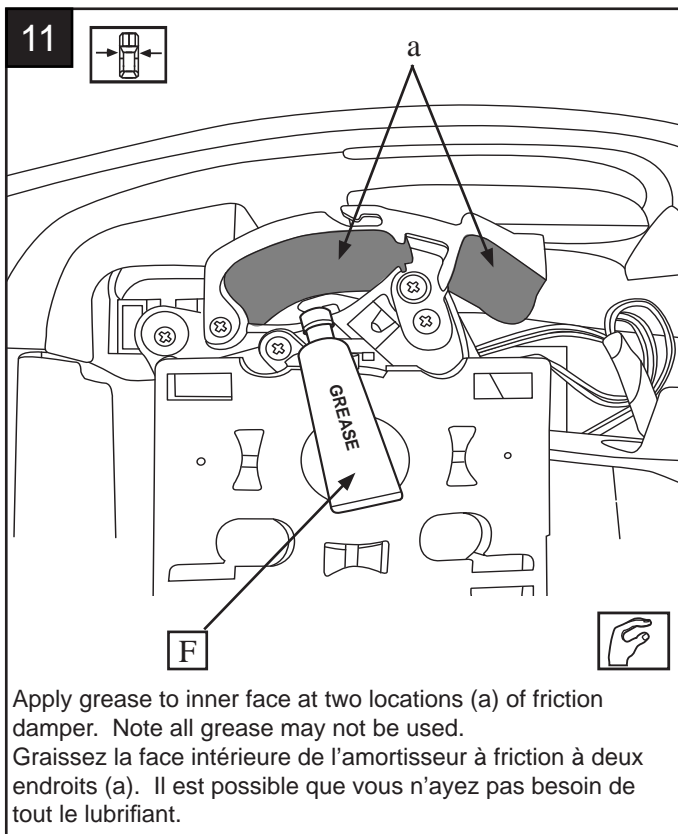
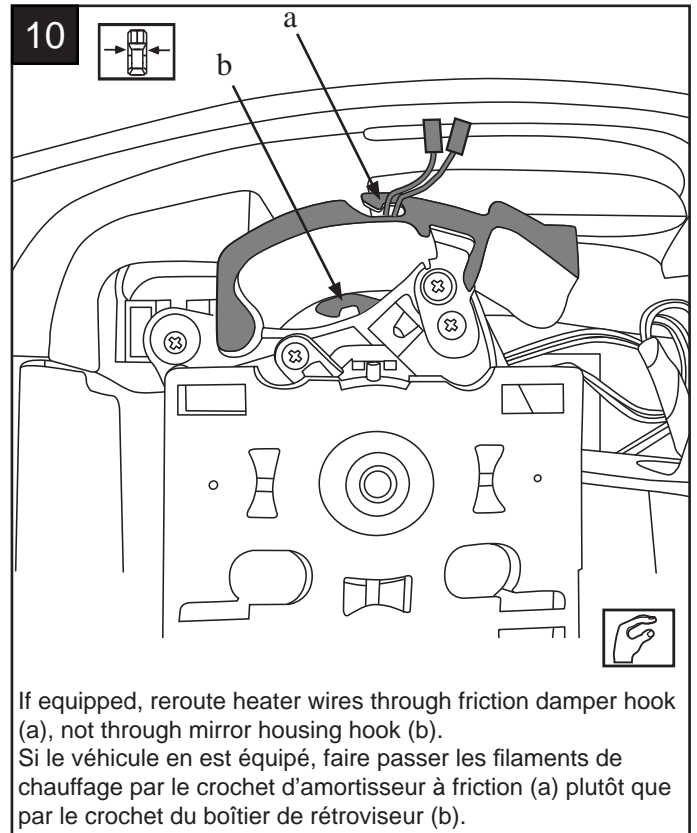
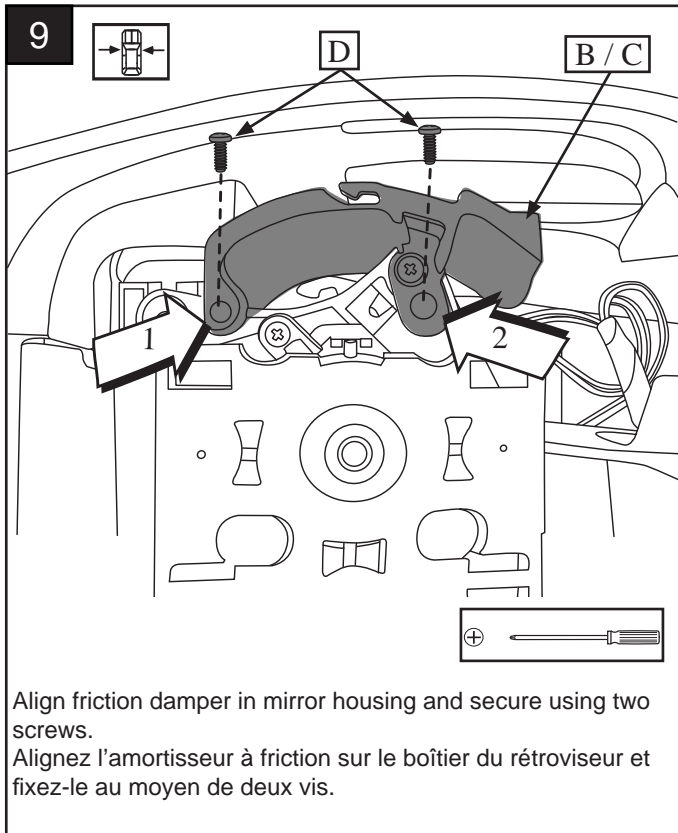

**13** 

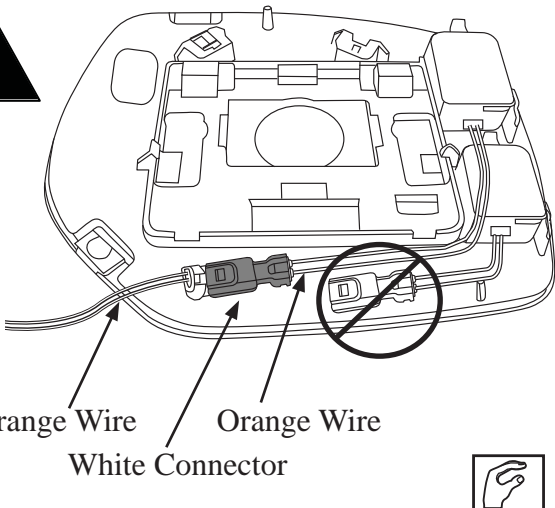

**!**

Orange Wire      Orange Wire  
White Connector



**!** Match the prearranged connector with orange wire to the mirror's approach light white connector with orange wire.  
**!** Brancher le connecteur prémonté à fil orange dans le connecteur blanc à fil orange de l'éclairage d'approche du rétroviseur.

**14** 

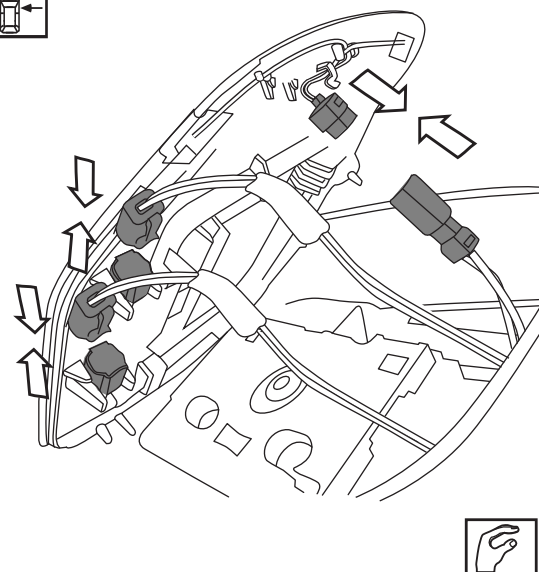



Plug prearranged vehicle connector's into mirror connector's.  
 Branchez le connecteur prémonté du véhicule sur le connecteur du rétroviseur.

**15** 

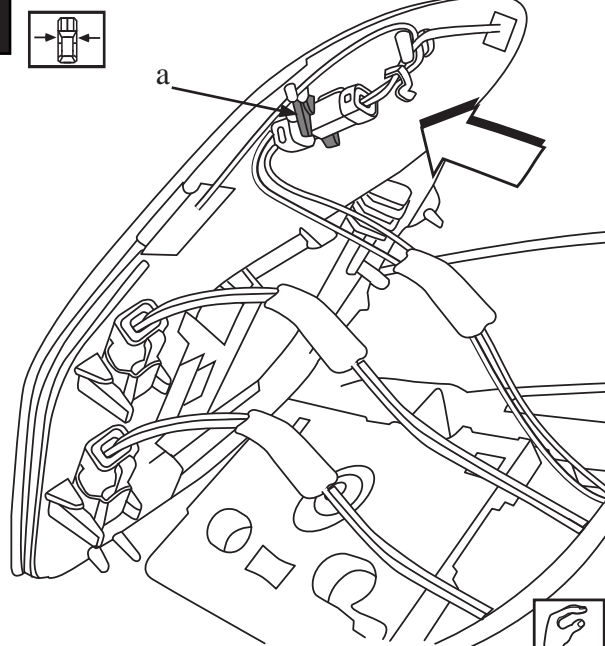



a

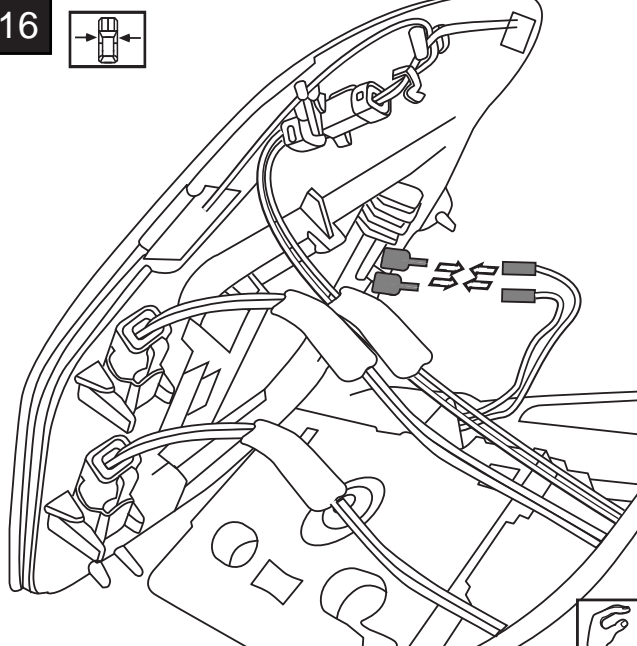

Secure connector pair (a) to mirror clip.  
 Fixez la paire de connecteurs (a) à l'attache du rétroviseur.

**16** 







If equipped, connect heater terminals.  
 Branchez les bornes de chauffage, si le véhicule en est équipé.

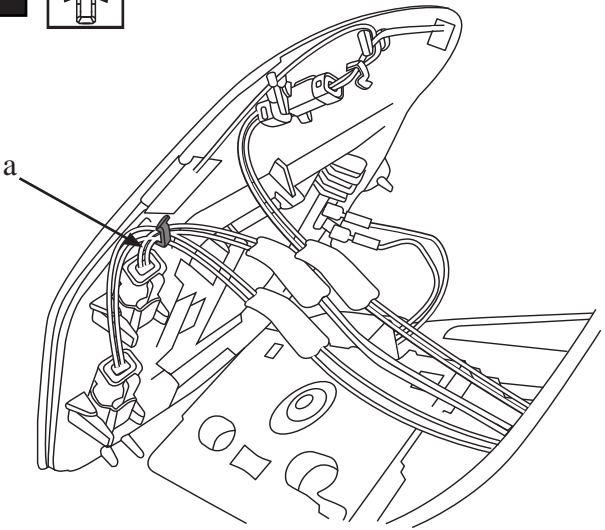

**17** 



**a**



Secure prearranged vehicle wires into mirror's clip. (a)  
Fixez les fils montés du véhicule en place dans l'attache du rétroviseur. (a)

**18** 

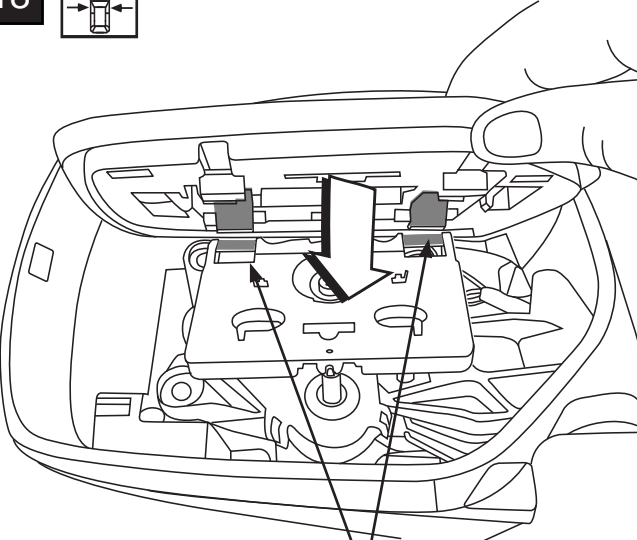



**a**

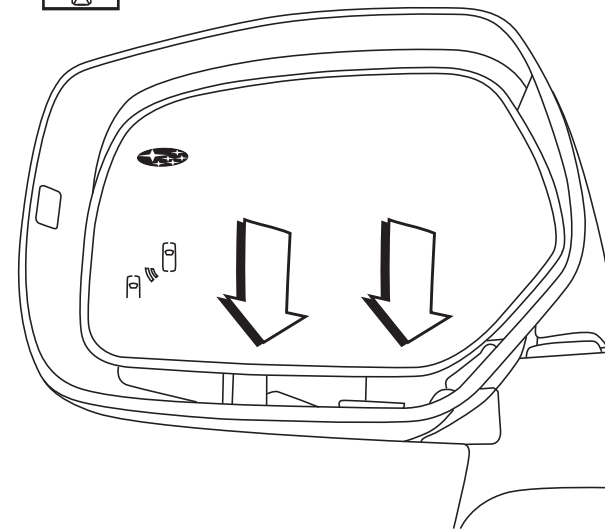

Hook top of mirror into vehicle motor pack (a).  
Accrochez le haut du rétroviseur au bloc-moteur du véhicule (a).

**19** 



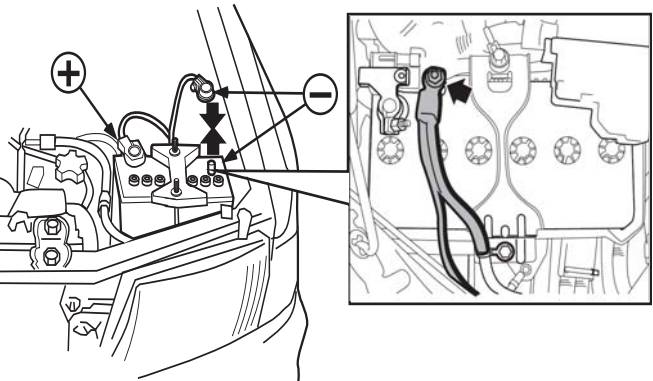

Secure mirror to vehicle motor pack at bottom by gently pressing until engaged. Repeat steps 2 -17 for passenger's side.  
Fixez le rétroviseur au bloc-moteur du véhicule, au bas, en appuyant doucement dessus jusqu'à ce qu'il s'enclenche.  
Reprendre les étapes 2 à 17 du côté du passager.

**20** 

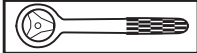

**+** **-**

10 mm 

12 mm 

Reconnect battery. If equipped reconnect eyelet cable.  
Rebranchez la batterie. Si elle en est équipée, rebranchez le câble de l'œillet.

21

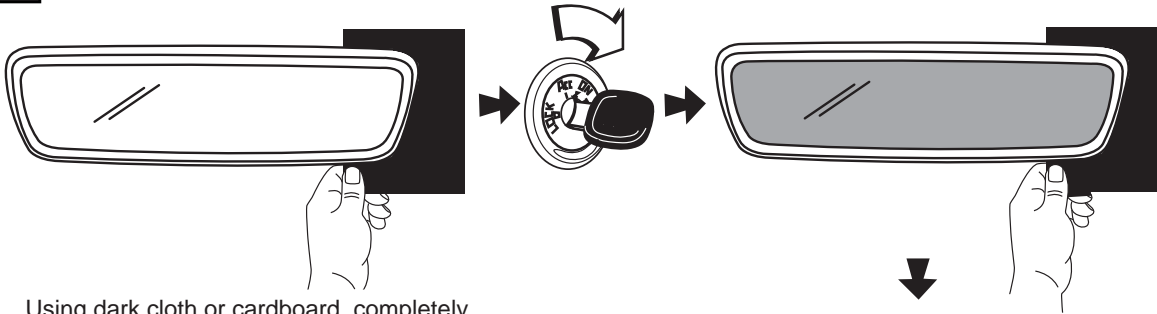

Using dark cloth or cardboard, completely cover forward-looking sensor.  
 Avec un linge sombre ou un carton, couvrez complètement le capteur pointé vers l'avant.

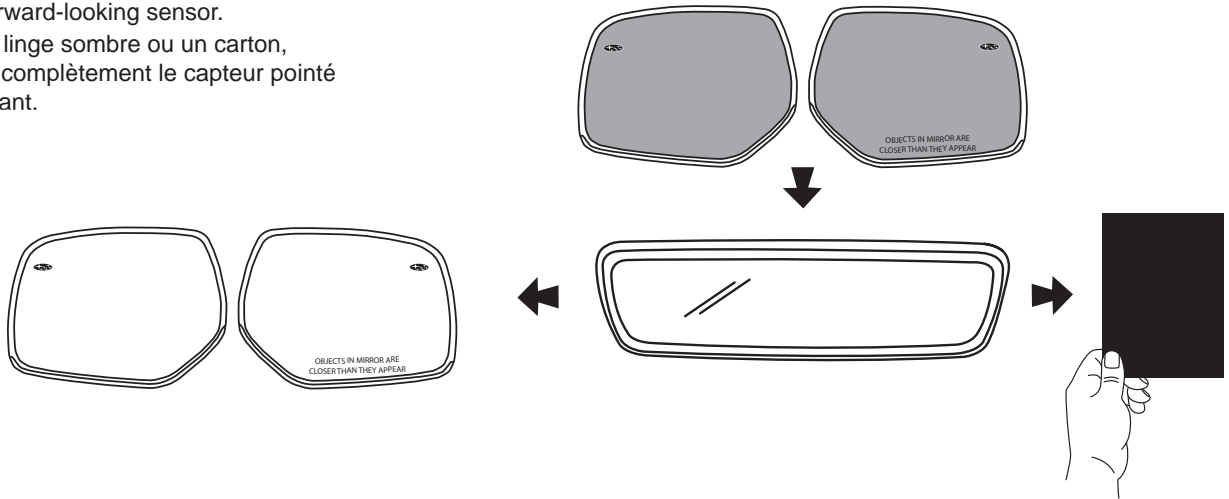

22

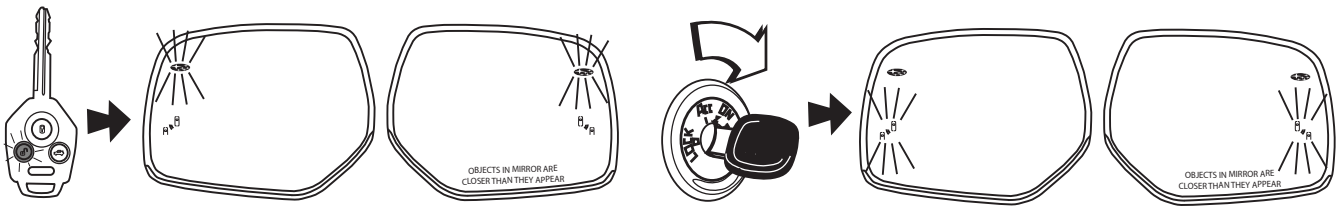

Blind spot module will light for approximately 1 second when ignition is turned on.  
 Le module d'angle mort s'allumera pendant une seconde environ au moment du démarrage.

<p>PART NUMBERS J201SSG600</p>	<p>ISSUE A</p>	<p>DATE 7/6/16</p>	<p>SUBARU OF AMERICA</p>	<p>PAGE 7/7</p>
------------------------------------	--------------------	------------------------	--------------------------	---------------------