



# SUBARU

PART NUMBER

NUMERO DE PIECE

J101SFN600

DESCRIPTION

Crosstrek-W Mud Flaps

DESCRIPTION

Garde-Boue: Crosstrek-W

INSTALLATION INSTRUCTIONS

INSTRUCTIONS D'INSTALLATION

KIT CONTENTS:

CONTENU DE L'ENSEMBLE

### FRONT ASSEMBLY ASSEMBLAGE AVANT

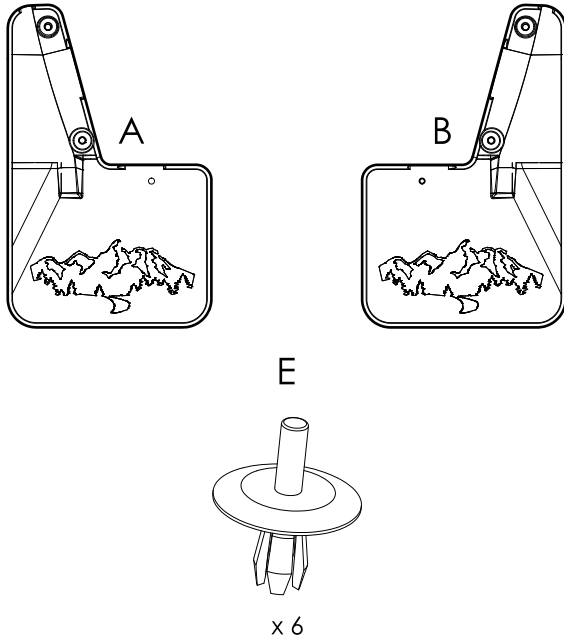

### REAR ASSEMBLY ASSEMBLAGE ARRIÈRE

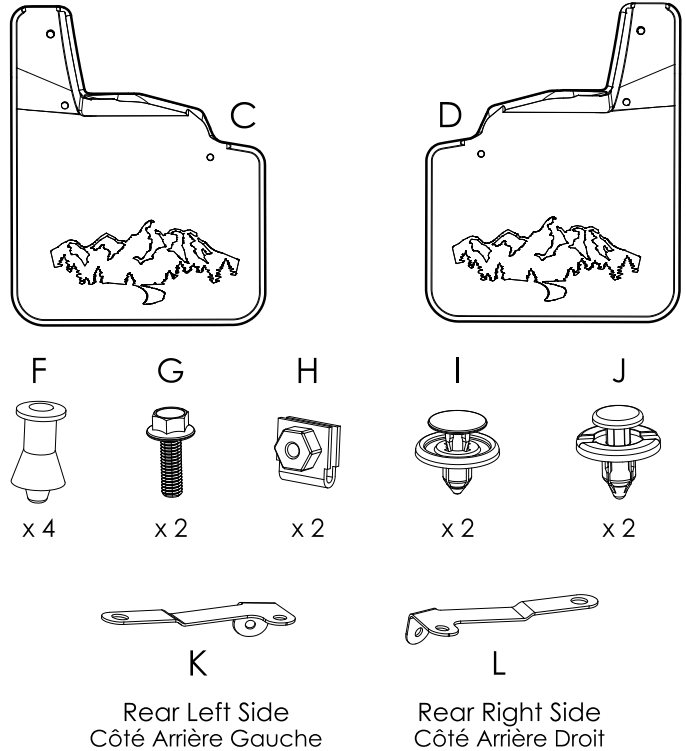

TOOLS REQUIRED:  
OUTILS REQUIS



Wipe clean  
Essuyer

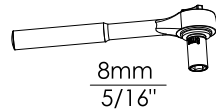
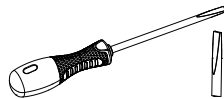

8mm  
5/16"



Φ2mm  
3/32"

Φ7mm  
9/32"

Φ8mm  
5/16"

**NOTE:** Mud flaps will decrease vehicle ground clearance. Use caution when driving over obstacles such as curbs and when entering automatic car washes.

**REMARQUE:** Les garde-boue réduisent la garde au sol du véhicule. Soyez prudent lorsque vous franchissez des obstacles tels que des bordures de trottoir et lorsque vous entrez dans les lave-autos automatiques.

OVER-TIGHTENING THE SCREWS IS NOT ADVISED AS THIS MAY CAUSE THE MUD-FLAP TO LOCALLY DEFORM.  
IL EST DÉCONSEILLÉ DE TROP SERRER LES VIS CAR CELA POURRAIT DÉFORMER LOCALEMENT LE GARDE-BOUE.

MEANING OF CHARACTERS:  
SIGNIFICATION DES SYMBOLES

REMOVE  
Enlever



INSTALL  
Installer



RE-USE  
Réutiliser



DISCARD  
Jeter / recycler



ISSUE

EDITION A

DATE

JUN 01, 2022

SUBARU OF AMERICA

PAGE

1/3



# SUBARU

PART NUMBER

NUMERO DE PIECE

J101SFN600

DESCRIPTION

Crosstrek-W Mud Flaps

DESCRIPTION

Garde-Boue: Crosstrek-W

INSTALLATION INSTRUCTIONS

INSTRUCTIONS D'INSTALLATION

1

Front Installation  
Installation a l'avant

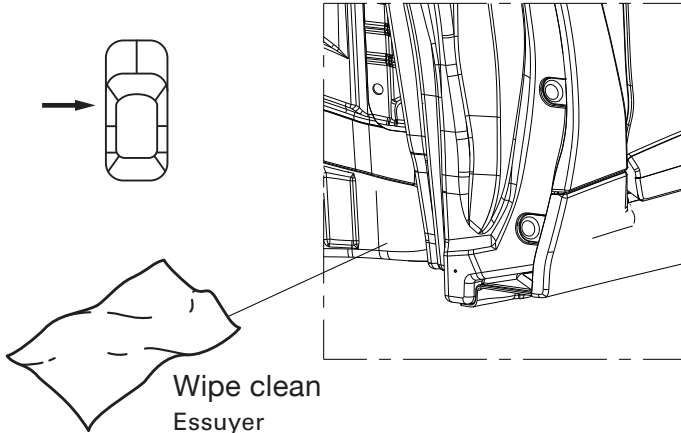

2

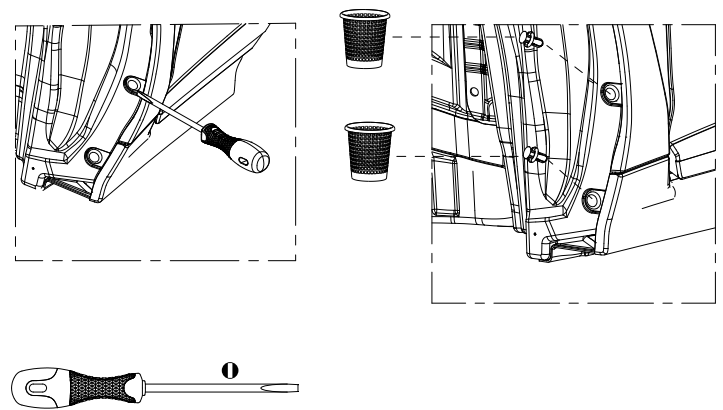

3

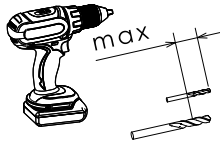

1. Turn wheel to gain access to drill location
  2. Drill  $\varnothing 2\text{mm}$  ( $3/32''$ ) hole as a guide hole up to 14mm ( $9/16''$ ) depth max
  3. Re-drill to  $\varnothing 7\text{mm}$  ( $9/32''$ ) up to 14mm ( $9/16''$ ) depth max
1. Tournez la roue pour accéder à l'emplacement de la perceuse
  2. Percez un trou de  $\varnothing 2\text{mm}$  ( $3/32''$ ) comme trou de guidage jusqu'à 14 mm ( $9/16''$ ) de profondeur max
  3. Re-percez à  $\varnothing 7\text{mm}$  ( $9/32''$ ) jusqu'à 14 mm ( $9/16''$ ) de profondeur max

4

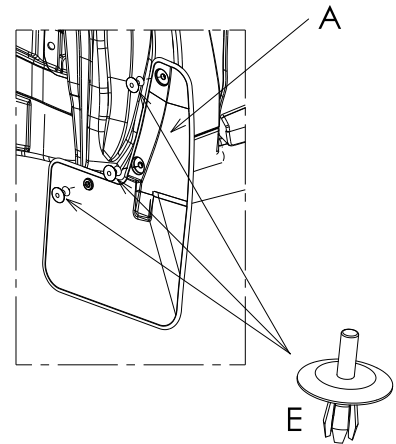

ISSUE

EDITION A

DATE

JUN 01, 2022

SUBARU OF AMERICA

PAGE

2/3



# SUBARU

PART NUMBER

NUMERO DE PIECE

J101SFN600

DESCRIPTION

Crosstrek-W Mud Flaps

DESCRIPTION

Garde-Boue: Crosstrek-W

INSTALLATION INSTRUCTIONS

INSTRUCTIONS D'INSTALLATION

### 5 Rear Installation Installation a l'arriere

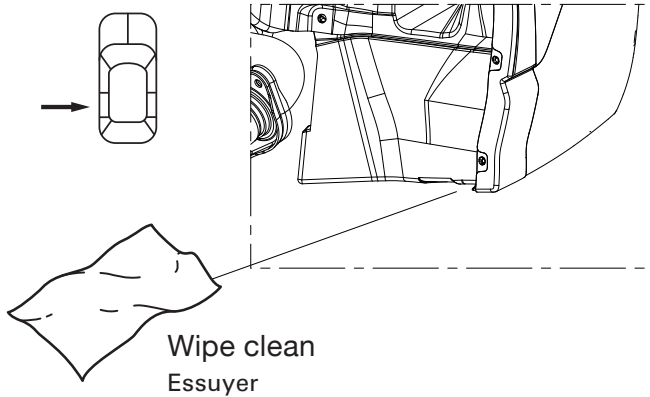

### 6

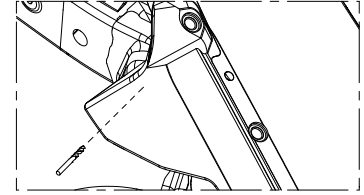
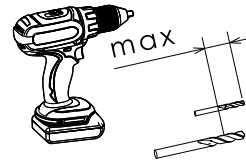

1. Drill  $\varnothing 2\text{mm}$  (3/32") hole as a guide hole up to 14mm (9/16") depth max
  2. Re-drill to  $\varnothing 8\text{mm}$  (5/16") up to 14mm (9/16") depth max
1. Percez un trou de  $\varnothing 2\text{mm}$  (3/32") comme trou de guidage jusqu'à 14 mm (9/16") de profondeur max
  2. Re-percez à  $\varnothing 8\text{mm}$  (5/16") jusqu'à 14 mm (9/16") de profondeur max

### 7

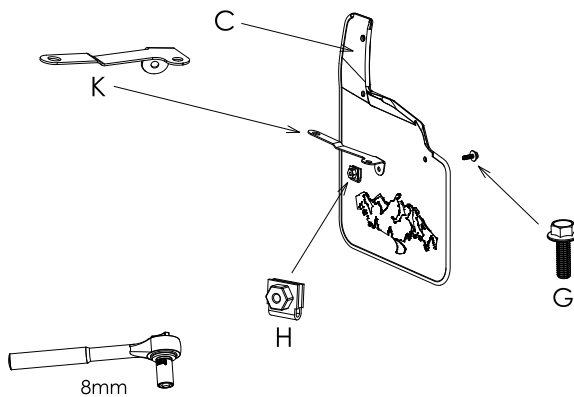

Screw torque:  
0.5 - 0.75 Nm (4.5~6.5 in-lb)

Couple de serrage des vis:  
0,5 à 0,75 N.m (4,5 à 6,5 po-lb)

### 8

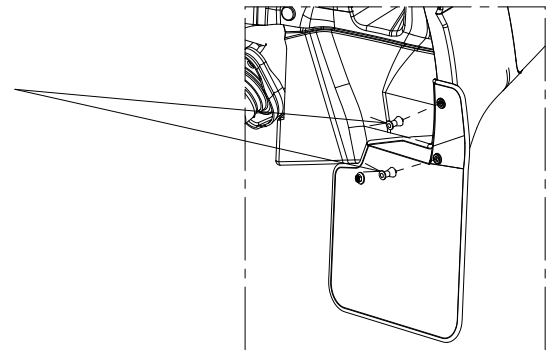

### 9

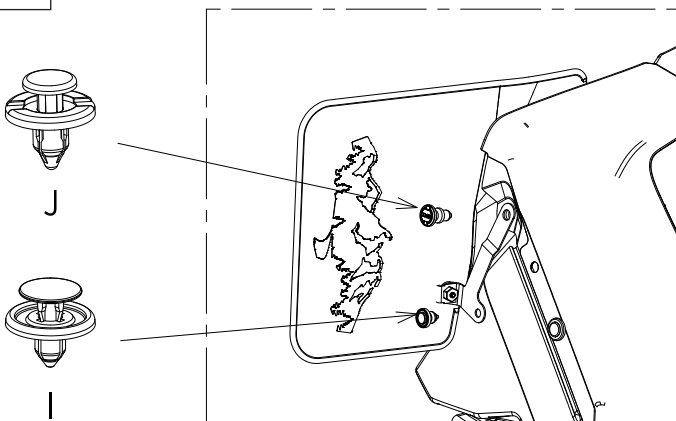

### 10

Repeat steps for the other side of the vehicle

Reprendre les memes etapes l'autre cote de vehicle

ISSUE

DATE

SUBARU OF AMERICA

PAGE

EDITION A

JUN 01, 2022

3/3