



# SUBARU

## INSTALLATION INSTRUCTIONS

# SUBARU

PART NUMBER: J101SAN800

DESCRIPTION: LEGACY/OUTBACK Body Side Molding

### PRE-INSTALLATION NOTES

- NOTE:** VEHICLE AND ALL INSTALLATION MATERIAL TEMPERATURES MUST BE 60°F (16°C) TO 86°F (31°C) BEFORE AND DURING INSTALLATION PROCESS.
- NOTE:** IF INSTALLING BODY SIDE MOLDING ALONG WITH DOOR EDGE GUARDS, THE BODY SIDE MOLDING MUST BE INSTALLED FIRST TO ALLOW PROPER ALIGNMENT OF THE INSTALLATION TEMPLATE.

### KIT CONTENTS:

A.

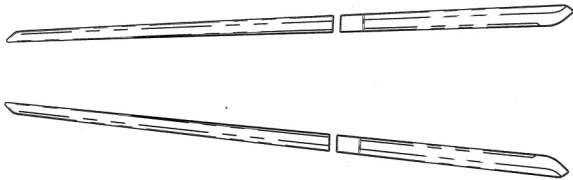

Body Side Molding 4 pcs.

B.



Alcohol Wipe x 4

C.

### Installation Template Front Door x 1

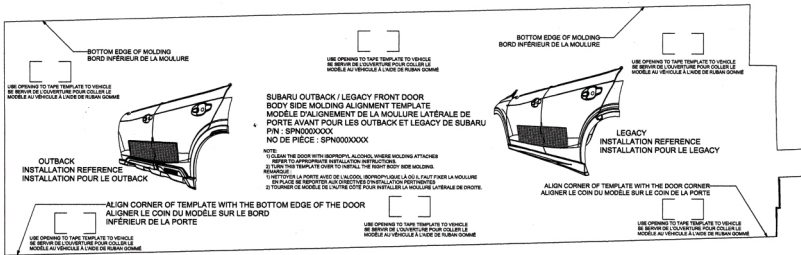

### Installation Template Rear Door x 1

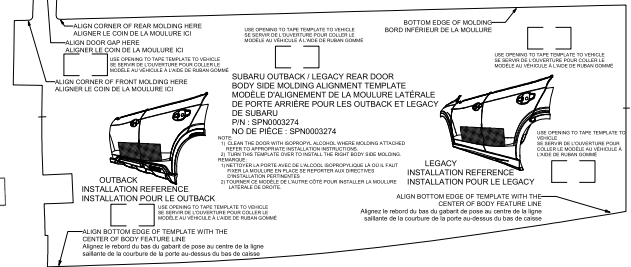

### TOOLS REQUIRED:



Masking Tape



Wash Supplies

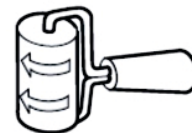

Rubber Roller

PART NUMBER:  
SPN0003268

ISSUE:  
REV-1

DATE:  
3-21-19

SUBARU OF AMERICA

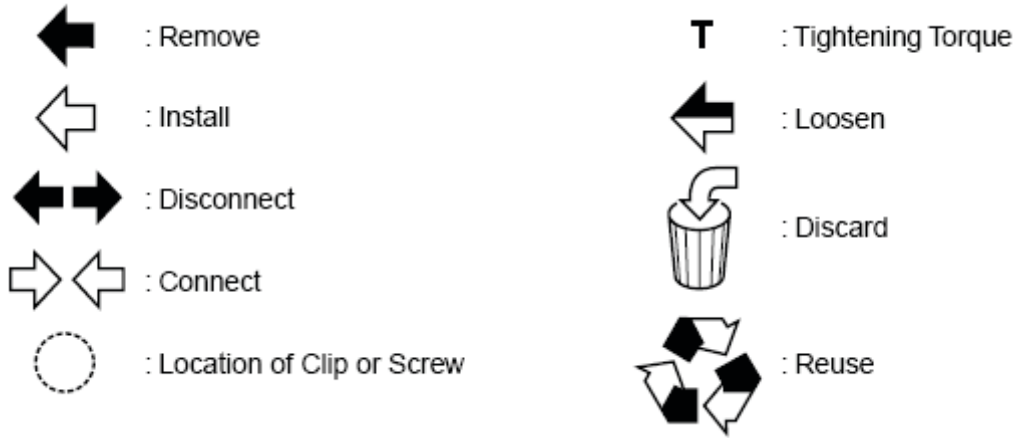

PAGE  
1/5

## MEANING OF CHARACTERS:

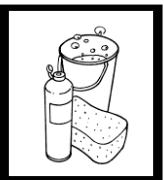

## Surface Preparation

**1** Make sure that all shaded installation surfaces (shown below) are washed and free of dirt, grease, and debris. Next use the alcohol wipes included in the kit and then dry. Inspect vehicle for damage before installation of body side molding. Before beginning, vehicle and body side molding must be at room temperature. If the temperature is below 60F (21 C) or above 110F (43 C). Let vehicle sit indoors until the doors and body side molding are at room temperature.

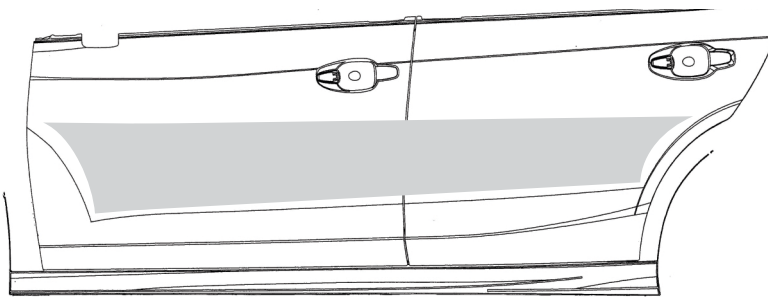

## Body Side Molding Installation

**2** Locate the body feature line on both front and rear doors. The bottom of molding location template lines up to it. The body feature lines are common on Legacy and Outback.

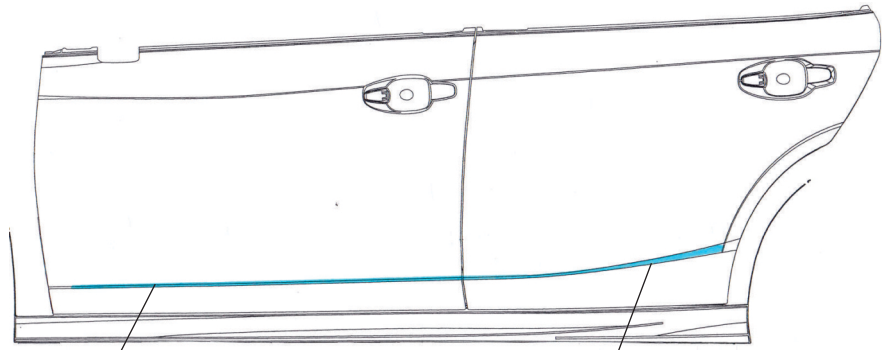

Front Feature Line      Rear Feature Line

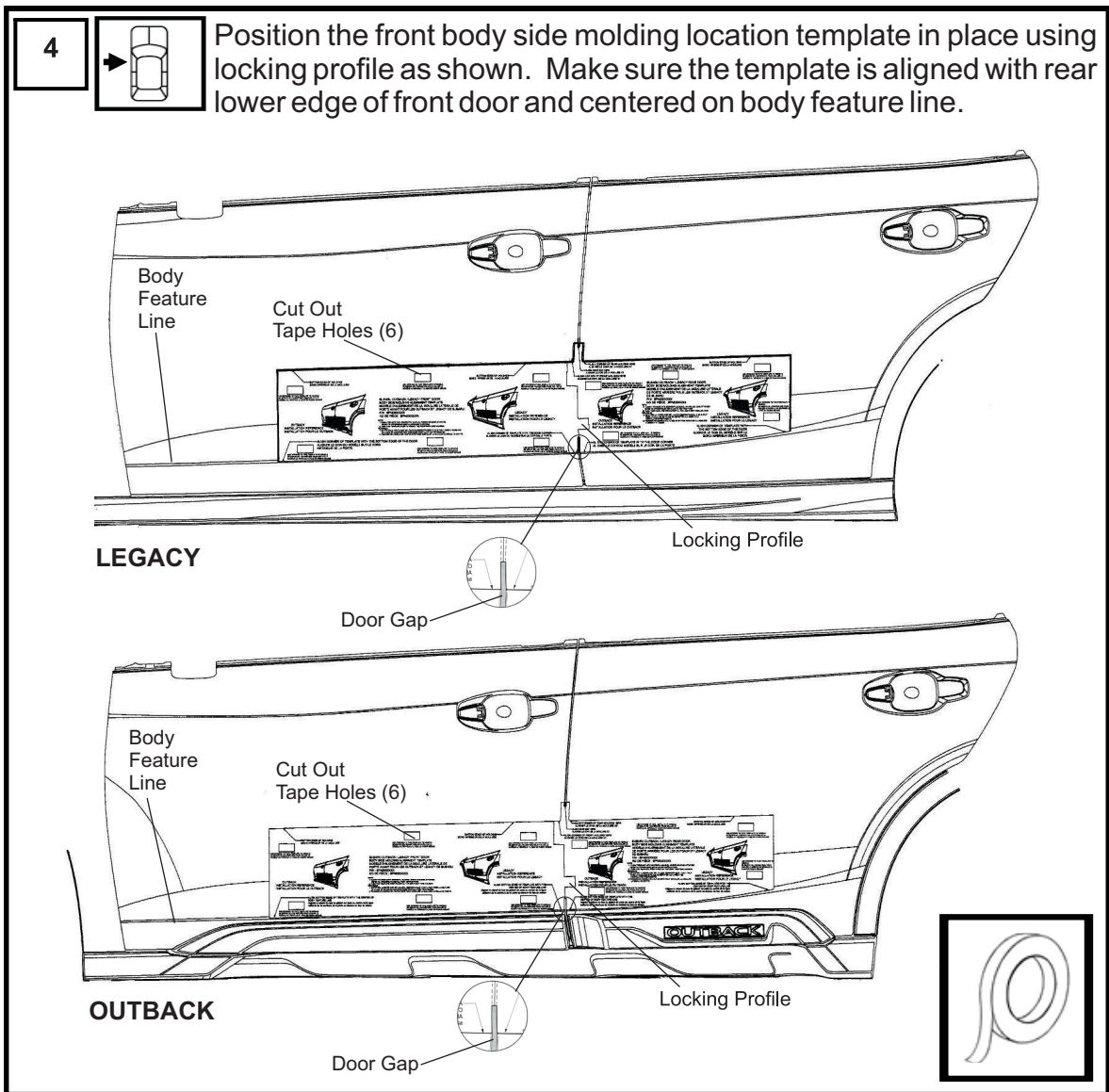
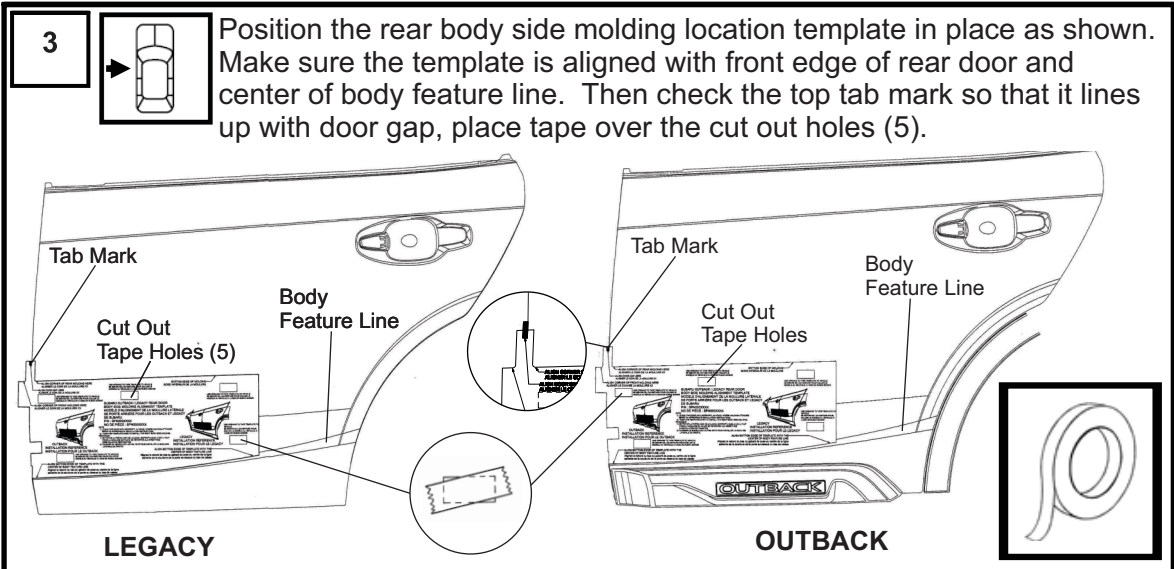

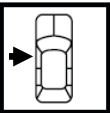
**5**  Remove tape liners from backside of body side moulding, using tabs start with horizontal to end pieces. Then shaped pieces with and without blue tape. **DO NOT TOUCH EXPOSED TAPE**

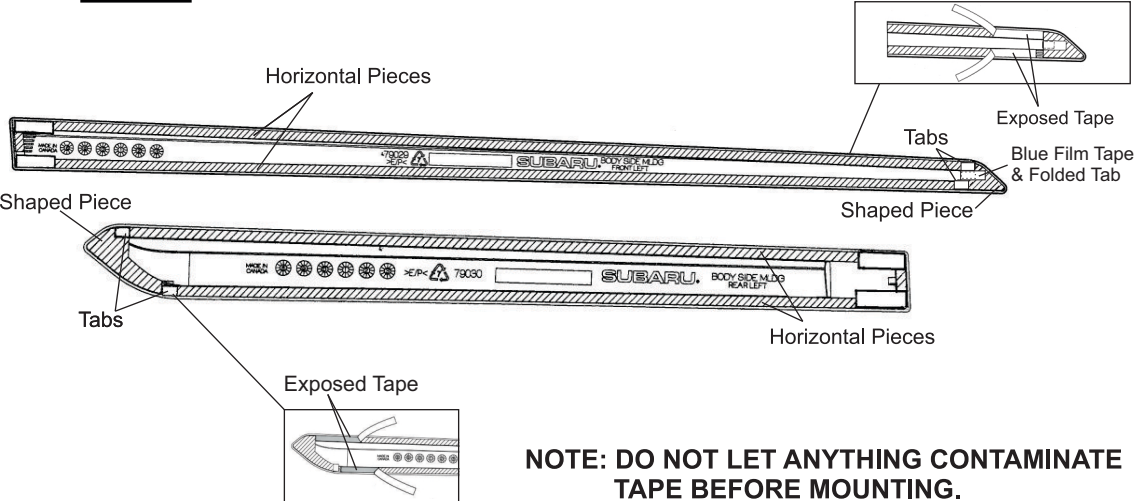

**NOTE: DO NOT LET ANYTHING CONTAMINATE TAPE BEFORE MOUNTING.**

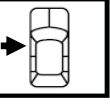
**6**  Place rear then front body side molding into locations as shown and tack down along entire lengths of tape. Remove templates and reverse for other side of vehicle.

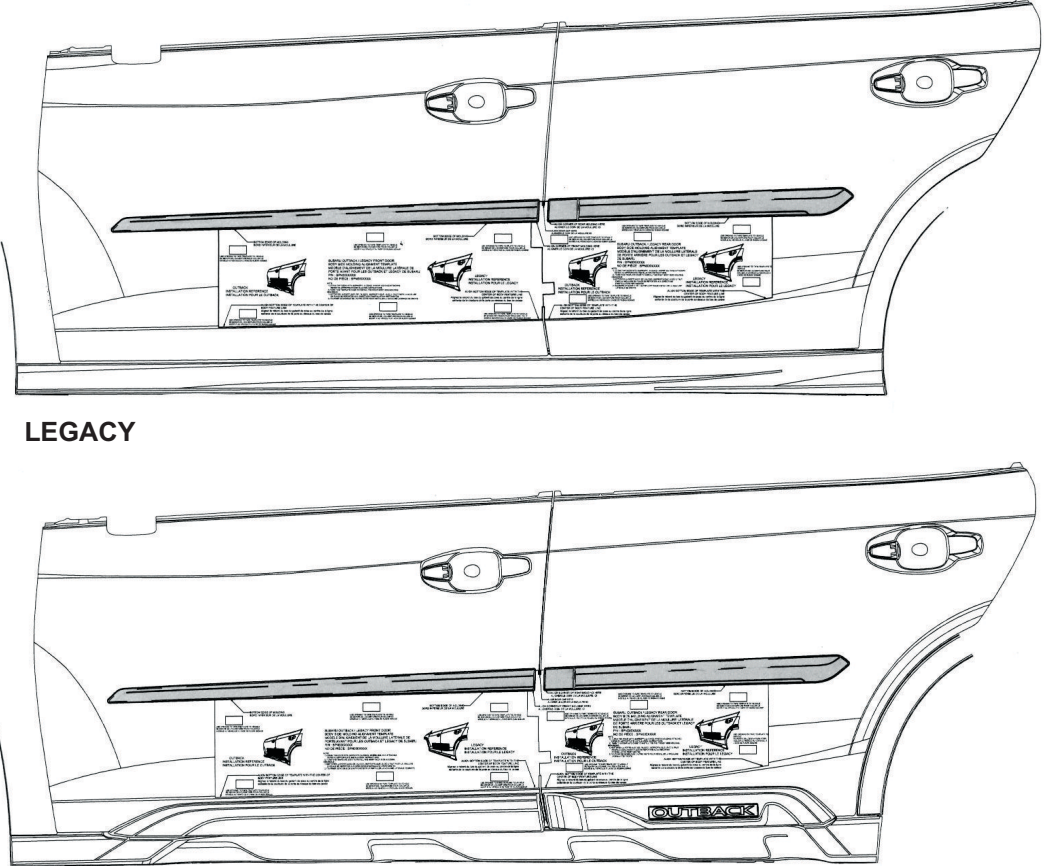

**LEGACY**

**OUTBACK**

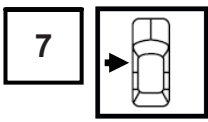

7

Using a rubber roller, apply firm, even pressure across the body side molding to adhere all pieces of tape to vehicle. Repeat procedure for the passenger side

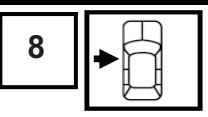
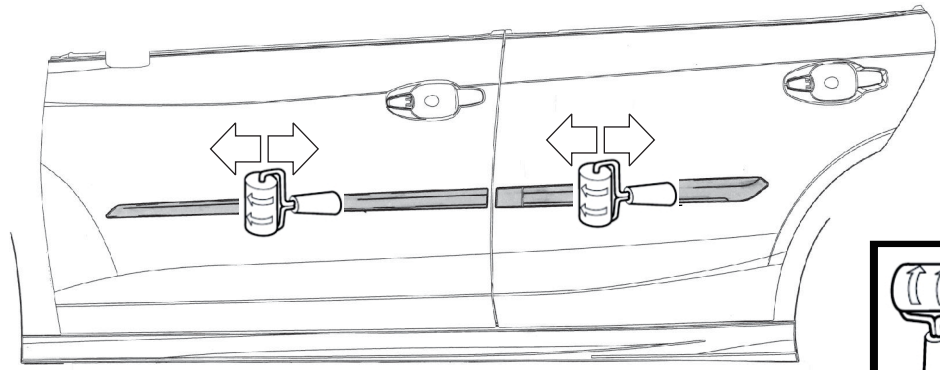

8

Installation is complete for drivers side of vehicle.

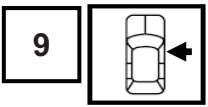
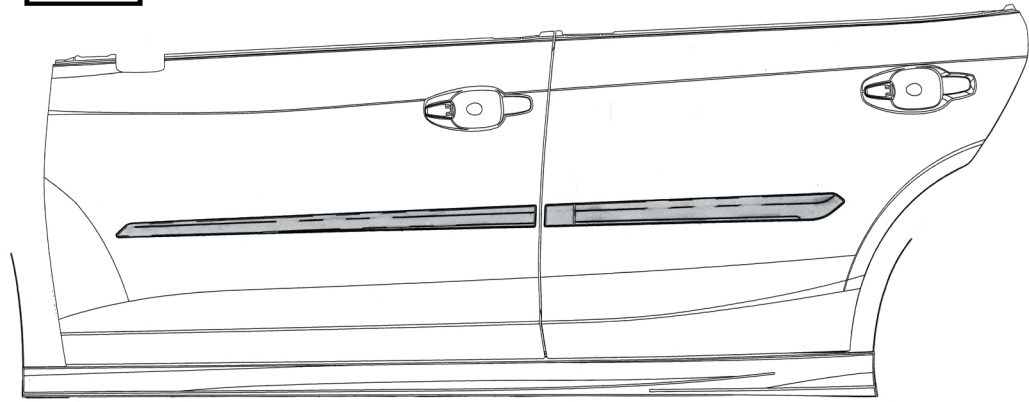

9

Repeat steps 1 through 8 on passengers side of vehicle, using other side of paper template.