



LED EMBLEM WRX

Installation Manual

Genuine Part Number: J1010VC201
 Applicable Model: WRX (VB) B Type or Later

Thank you for purchasing the Subaru Genuine LED EMBLEM WRX.
 This manual describes the procedure to install the LED EMBLEM WRX on the WRX (VB) B.
 Be sure to read this manual before installing this product and follow the instructions described below.

Part Number

Genuine Part Number		Configuration
J1010VC201	LED EMBLEM WRX	J1010VC310 、 H4510VC203

Component Parts

J1010VC310	LED EMBLEM WRX	No.	Part Name	Quantity
		1	LED Emblem	1
		2	Exterior Harness	1
		3	Screw M4 x 12 mm (Black)	3
		4	Holder Clamp	2
		5	Banding Band	8
		6	Cushion Tape (90 × 80 mm)	2
		7	Instruction Manual	1

J4510VC203	HARNESS SET	No.	Part Name	Quantity
		8	Cabin Harness	1
		9	Banding Band	1

Parts Sold Separately

J1010VC120 / 130	Front Grille	No.	Part Name	Quantity
<p>※ J1017VC130 has the STI mark</p>		10	Front Grille	1
		11	Camera Cover	1
		12	Screw M4 x 12 mm (Silver)	2
		13	Instruction Manual (for the Front Grille)	1

⚠ Installation Precautions

For your safety, important instructions that should be observed are shown with the following symbols in this Installation Manual.

⚠ CAUTION This refers to situations in which injury may occur or property may be damaged if the caution instructions are not followed.

👉 NOTE This denotes things that you should be made aware of so you can do the work quickly.

1. Park the vehicle on a level place, apply the parking brake, and use wheel chocks.
2. Make sure to arrange vehicle parts by part when removing them so that you do not lose the tapping screws, nuts and bolts, and so you do not mistaken them when reinstalling the vehicle components. Also, pay due attention not to damage the vehicle and the removed parts during work.
3. When you disconnect the battery terminal, radio channels and other items saved in memory will be deleted, so make a note or backup of them before you disconnect the battery terminal.
4. After reconnecting the battery, some functional parts of the vehicle may need to be initialized. Be sure to initialize them after completing the operation.
5. Oil or dirt on the application surface for the holder clamp may cause it to drop or peel off. Therefore, thoroughly wipe the surface with Degreaser (nonane is recommended) or the like and ensure open flame is not near it.
6. To prevent damage to the vehicle and vehicle parts when removing vehicle parts and installing the product, be sure to perform the work on a Protective Sheet.
7. If the ambient temperature is 15°C or lower, the adhesive strength of the Double-sided Tape will decrease. Therefore, warm up the application surface and the Double-sided Tape surface with a Dryer before installation. Additionally, ensure that it does not get wet for about 24 hours after attaching the Double-sided Tape.
8. To prevent faults from poor connections and static electricity from the LED Emblem, ensure that the electrode terminal on the LED Emblem connector does not touch your bare hands or metallic tools.

Before Installing the Product

- Remove the minus (-) cable on the battery.

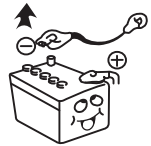

Installation of Parts

- Use proper size tools.



- Pay attention to the back side and do not allow any wire harness to get caught.

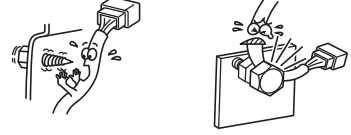

Handling of Wire Harness

- Hold the connector body to disconnect it.
- Bundle the vehicle wire harnesses together and secure with a clamp.
- Connect the connectors securely.
- Do not pull them forcibly.

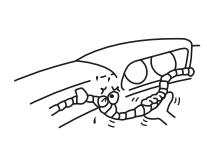
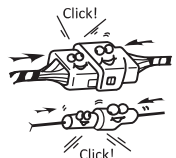
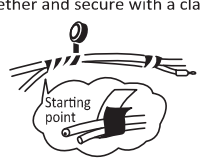
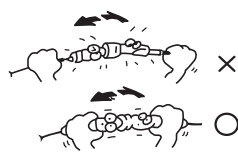

- Protect wires from burrs and edges with Packing Tape.

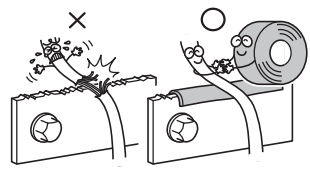

- Make sure to fully waterproof wiring if wiring from a grommet.

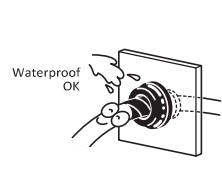

- Handle the wire harnesses in such a way that vehicle parts can be reinstalled correctly.

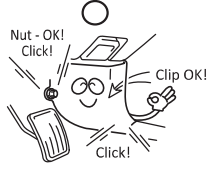

Handling of Clamps

- Do not clamp bare wires.
- Cut any excess cable.
- Be careful that cut ends do not touch other wire harnesses.
- Clamp the connector so that it does not make an abnormal sound.



After Completion of Installation

- Be sure to reassemble all the vehicle parts that have been removed.



⚠ CAUTION

Follow the Maintenance Guide for the procedure to disconnect and connect battery terminals and to read the precautions when performing the work. Also perform the reconfiguration work as per the Maintenance Guide after installation.

Tools Required

Clip Remover, Phillips-head Screwdriver, Flathead Screwdriver, Torque Screwdriver, Diagonal Pliers, Scissors, Protective Tape, Protective Sheet, Cloth, Masking Tape, Adhesive Tape, Degreaser (nonane is recommended), Dryer (if ambient temperature is 15°C or below)

Post-installation Diagram

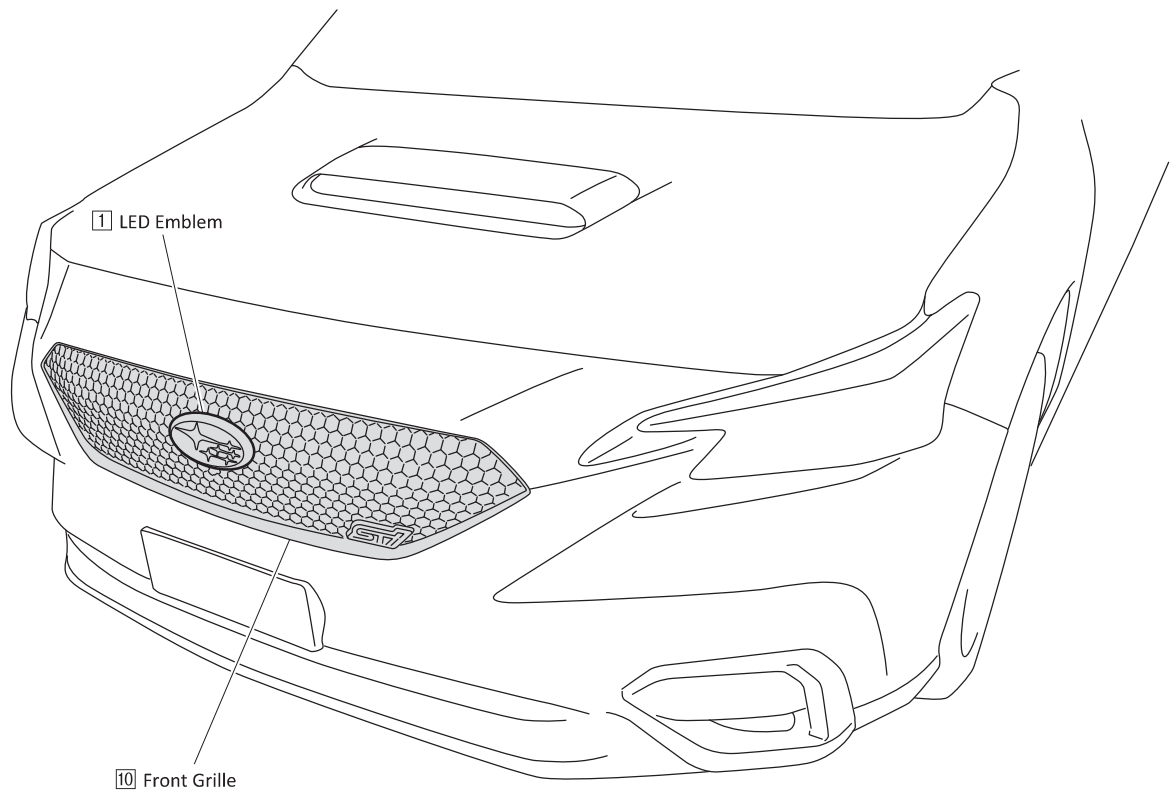

Installation Procedure

Figure shows the LH side.

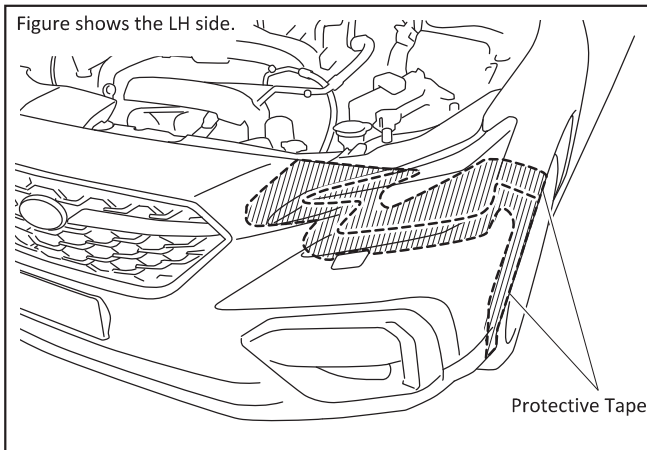

TG-ZW-A01

1. Removing the Front Bumper

- (1) Apply Protective Tape to the shaded area shown in the figure.
- (2) Repeat the same procedure for the right side.

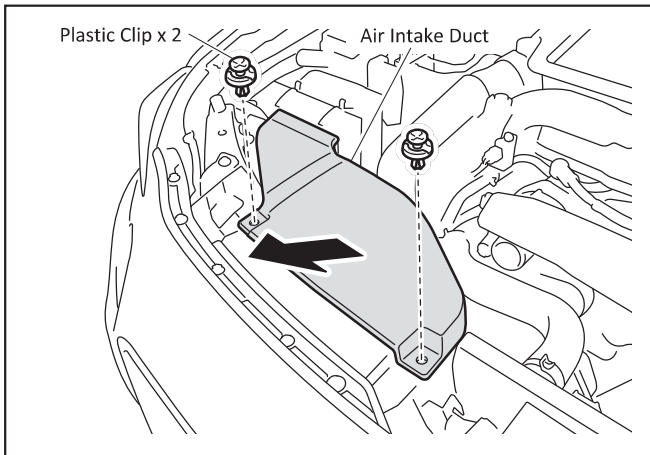

TG-ZW-A02

- (3) Remove the Plastic Clips (2 pcs), and remove the Air Intake Duct by lifting it upwards.

⚠ CAUTION

The removed vehicle parts will be reused, so be careful not to misplace them.

(Adopt this practice throughout the rest of the procedure).

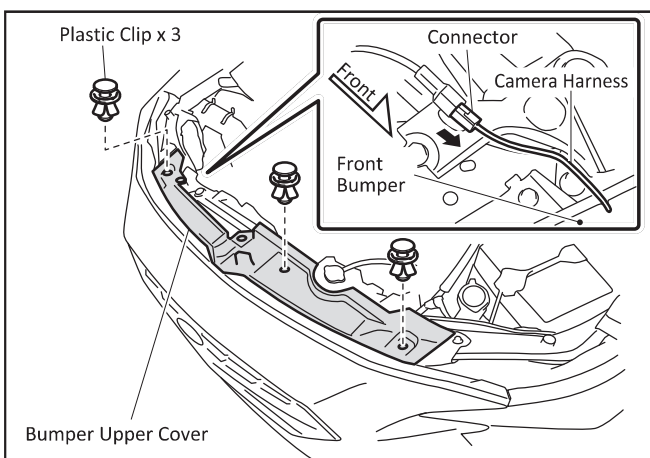

TG-ZW-A03

- (4) Remove the Plastic Clips (3 pcs), and remove the Bumper Upper Cover.

- (5) Remove the camera harness connector.

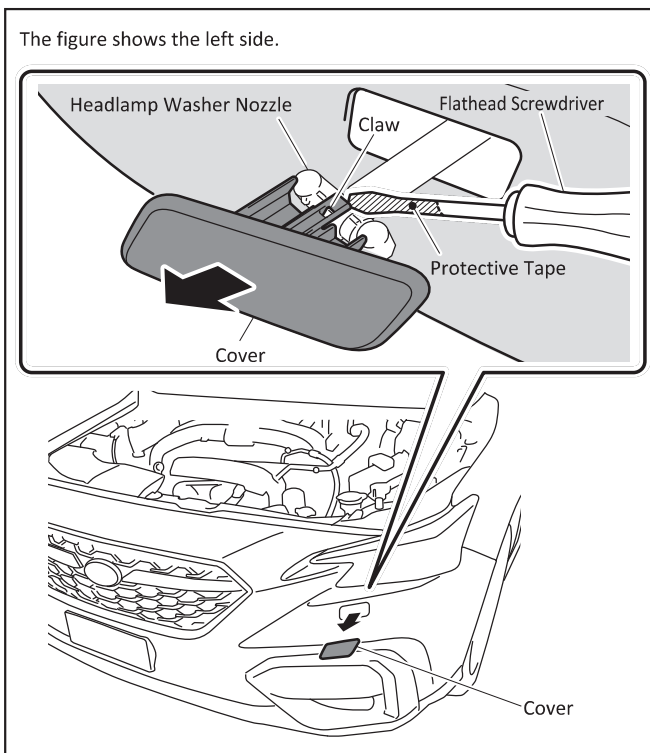

TG-ZW-A04

- (6) Pull out the Head Lamp Washer Nozzle, disengage the Claw, and remove the cover.

- (7) Repeat the same procedure for the right side.

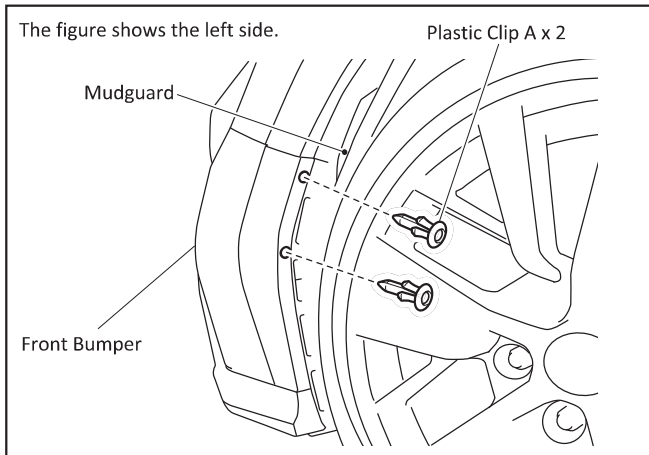

TG-ZW-A05

- (8) Remove Plastic Clip A (2 pcs) that secure the Front Bumper.
- (9) Repeat the same procedure for the right side.

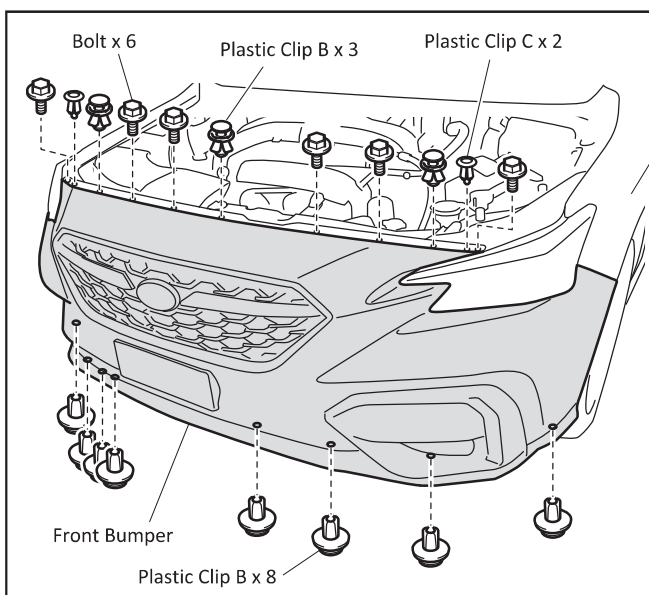

TG-ZW-A06

- (10) Remove the Bolts (6 pcs), Plastic Clip B (top: 3 pcs) (bottom: 8 pcs), and Plastic Clip C (2 pcs).

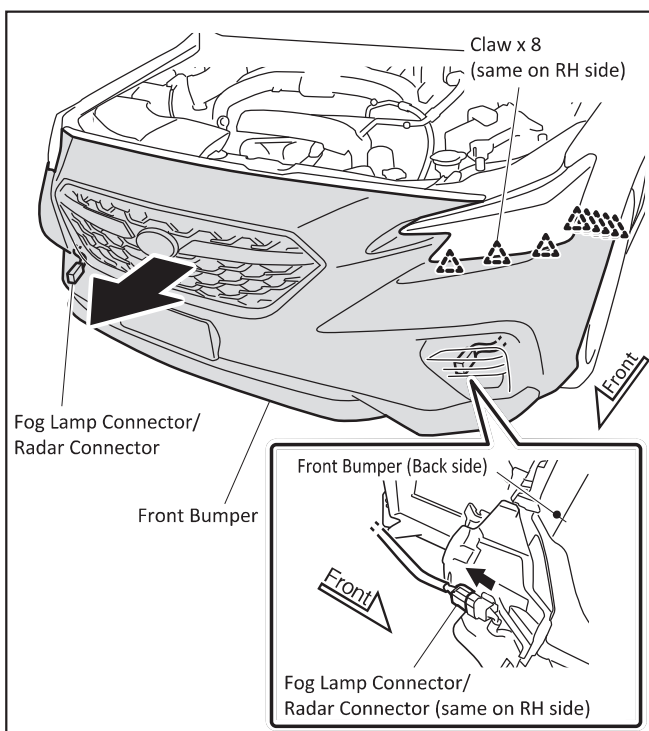

TG-ZW-A07

- (11) Disengage the Claws (16 places on right and left sides) and remove the Front Bumper, placing it at the front of the vehicle.

CAUTION

Be careful not to break the harness when removing the Front Bumper.

- (12) Disconnect the Fog Lamp Connector/Radar Connector and then remove the Front Bumper.

CAUTION

Place the Front Bumper on a blanket or Protective Sheet so that it will not get scratched.

2.Replacing the Front Grille

<Only When Installing the Front Grille (LED Emblem)/Front Grille STI (LED Emblem)>

NOTE

To install the **LED Emblem** on the **Vehicle Grille**, go to P. 7, "**3. Installing the LED Emblem**".

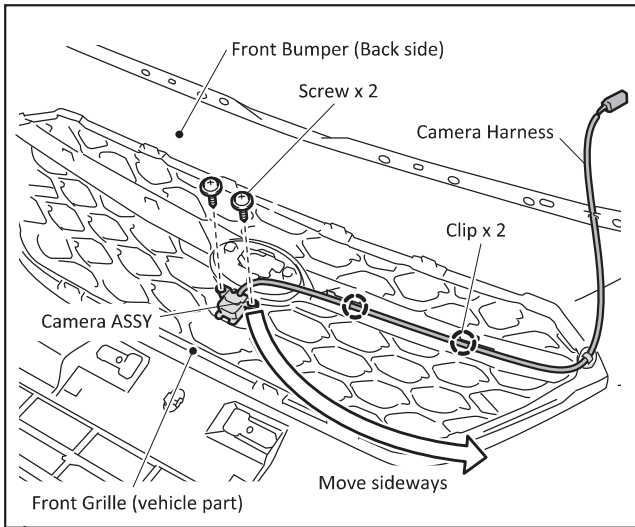

TG-ZW-A08

<For vehicles with a camera>

- (1) Remove the Screws (2 pcs).
- (2) Disengage the Clips (2 pcs), and detach the Camera ASSY from the Front Grille.

CAUTION

- (1) Be sure to remove or install the Front Bumper above a blanket or Protective Sheet so that it will not get scratched.
(Adopt this practice throughout the rest of the procedure).
- (2) Protect the Camera with a blanket or the like so that it does not get scratched.

NOTE

The removed Screws will not be reused.

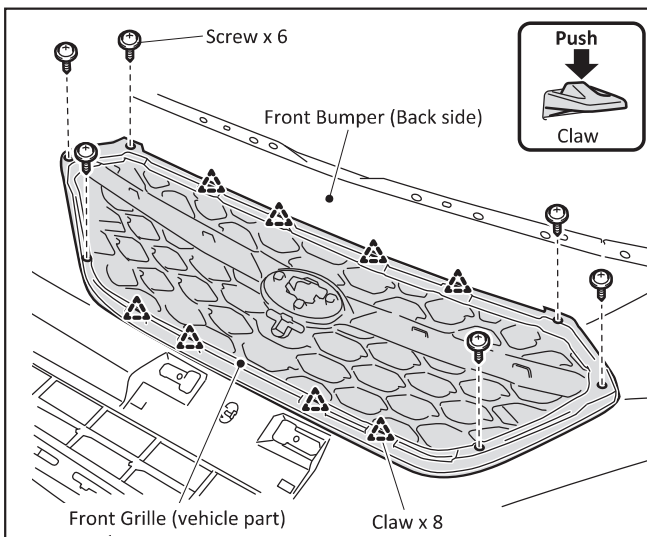

TG-ZW-A09

<Common Parts>

- (1) Remove the Screws (6 pcs).
- (2) Disengage the Claws (8 places) and remove the Front Grille (vehicle part).

CAUTION

Be sure to remove or install the Front Bumper above a blanket or Protective Sheet so that it will not get scratched.
(Adopt this practice throughout the rest of the procedure).

NOTE

The removed Screws will be reused.

CAUTION

Take extra care not to scratch the removed vehicle grille and return it to the customer.

- (3) Engage the Claws (8 places) to attach the Front Grille to the Front Bumper.
- (4) Secure the Front Grille with the Screws (6 pcs).

CAUTION

Tightening the Screws with an electric (high torque) tool may damage the grille so tighten the Screws by hand using a Phillips-head Screwdriver.
(FYI: Tightening torque 1.5 N·m±0.3)

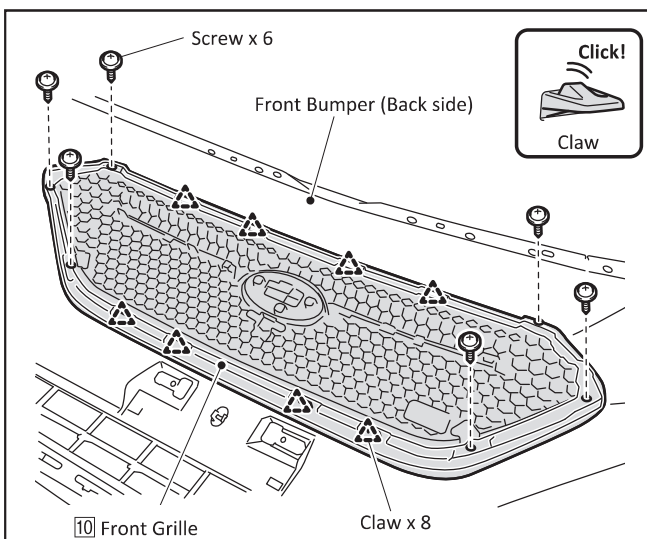

TG-ZW-A10

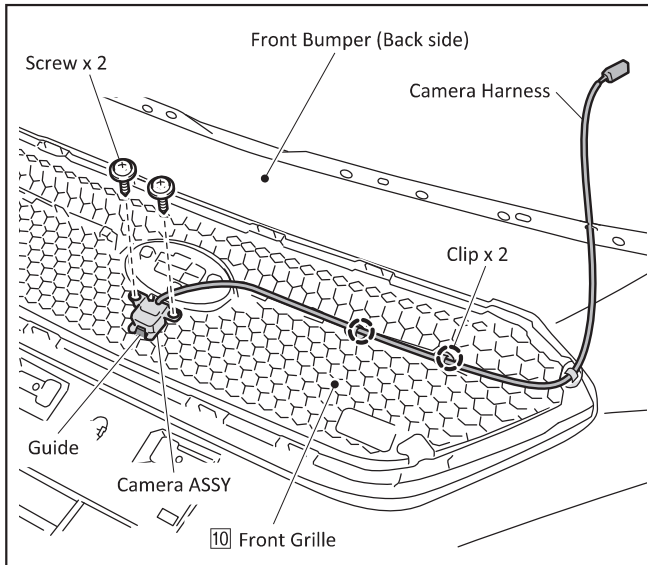

TG-ZW-A11

<For vehicles with a camera>

- (1) Attach the Camera ASSY to the Front Grille with the Screws (2 pcs) and Guide (1 place).

Tightening torque: 1.1 N·m ±0.2

⚠ CAUTION

Use the Screws (2 pcs) included with the product.

- (2) Place the Camera Harness in the Front Grille guide, and then engage the Clips (2 pcs) to secure the Camera Harness.

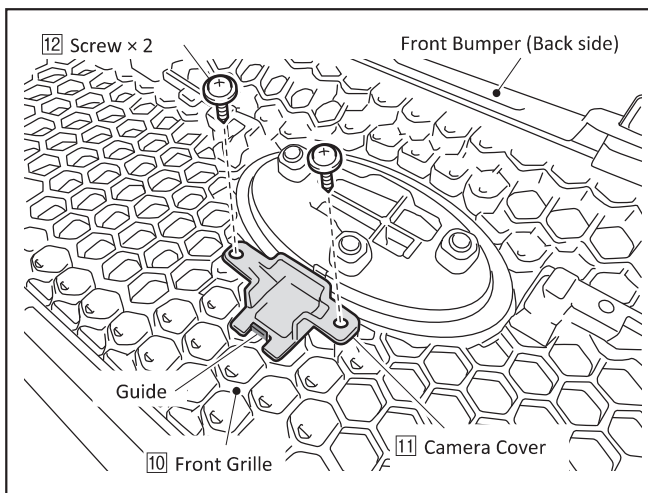

TG-ZW-A12

<For vehicles without a camera>

- (1) Attach the camera cover to the Front Grille with the Screws (2 pcs) and Guide (1 place).

Tightening torque: 1.1 N·m ±0.2

⚠ CAUTION

Use the Screws (2 pcs) included with the product.

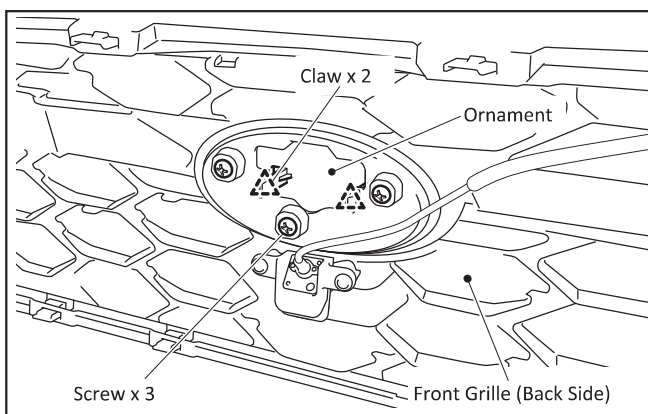

TG-ZW-B01

3. Installing the LED Emblem

- (1) Remove the Screws (3 pcs).
- (2) Disengage the Claws (2 places) and remove the Ornament.

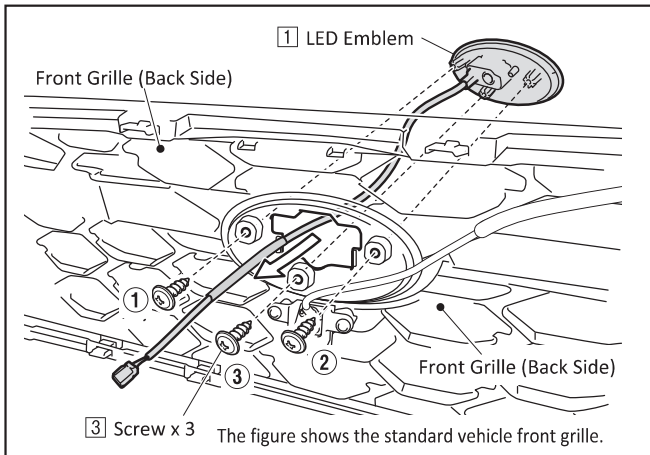

TG-ZW-B02

(3) In order of the numbers in the figure, install the LED Emblem onto the Front Grille with the Screws (3 pcs).

Tightening torque: 1.1 N·m ±0.2

CAUTION

Use the Screws (3 pcs) included with the product. After installing the LED Emblem, check that the LED Emblem is not loose.

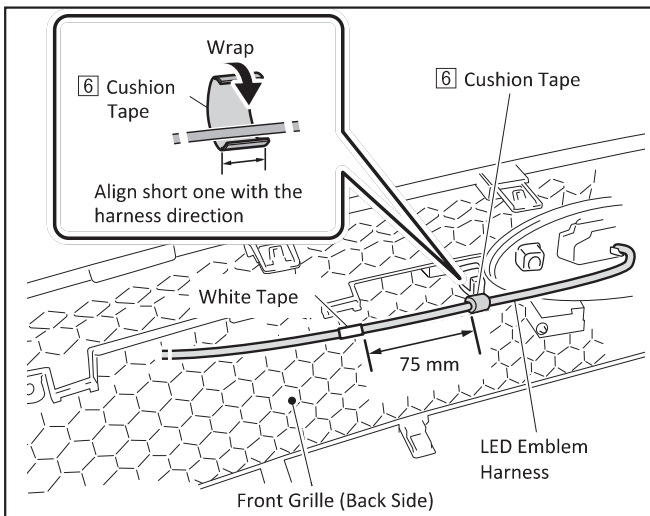

TG-ZW-B14

<Only When Installing the Front Grille (LED Emblem)/Front Grille STI (LED Emblem)>

(1) In accordance with the dimensions in the figure, wrap Cushion Tape around the LED Emblem Harness.

NOTE

Peel off and use one piece at a time of Cushion Tape along the cut line.

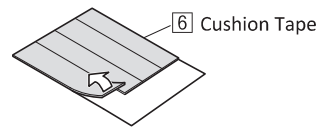

<When installing the LED Emblem on the vehicle grille>

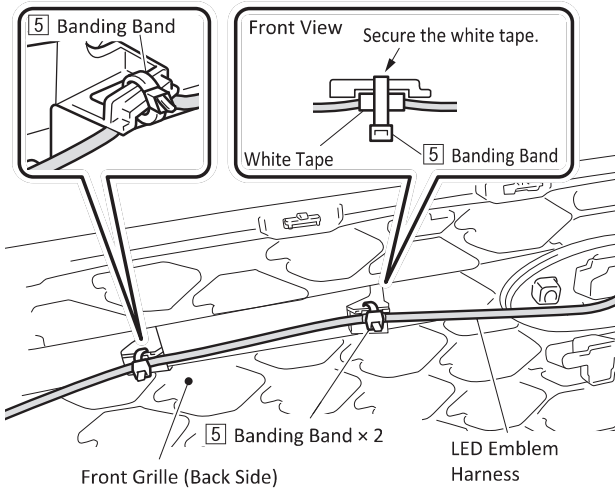

<Common Parts>

(4) Secure the LED Emblem harness to the Front Grille with Banding Band (2 pcs).

NOTE

<Only When Installing the Front Grille (LED Emblem)/Front Grille STI (LED Emblem)>
Place the part of the harness with the cushion tape wrapped around it in the Front Grille guide to connect it.

<When installing the Front Grille (LED Emblem)/Front Grille STI (LED Emblem)>

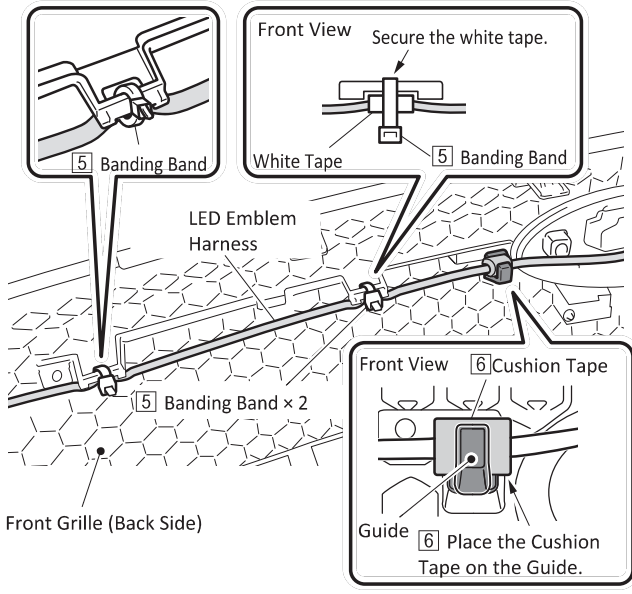

TG-ZW-B04

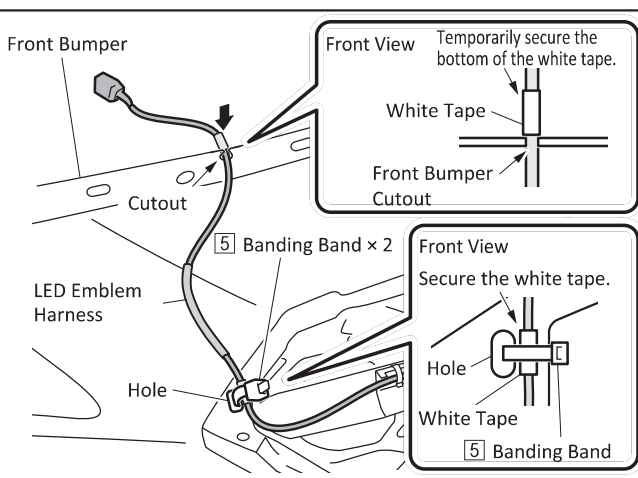

TG-ZW-B08

(5) Secure the LED Emblem harness to the hole in the Front Bumper with Banding Band (1 pc).

(6) Temporarily secure the LED Emblem harness to the cutout in the Front Bumper.

CAUTION

Take care to ensure that the LED Emblem harness connector is not removed from the cutout until you re-install the Front Bumper.

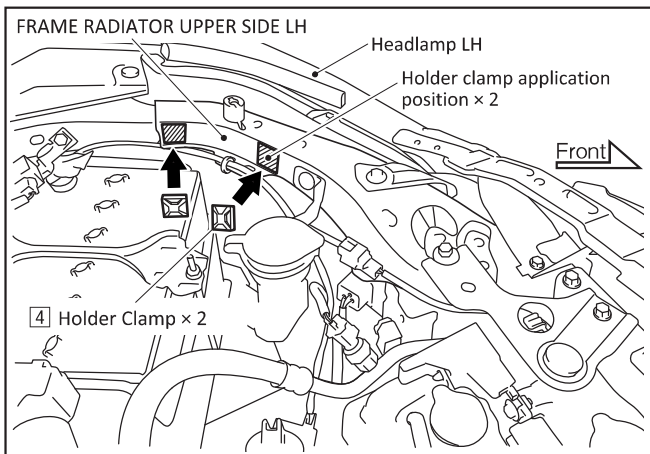

TG-ZW-B05

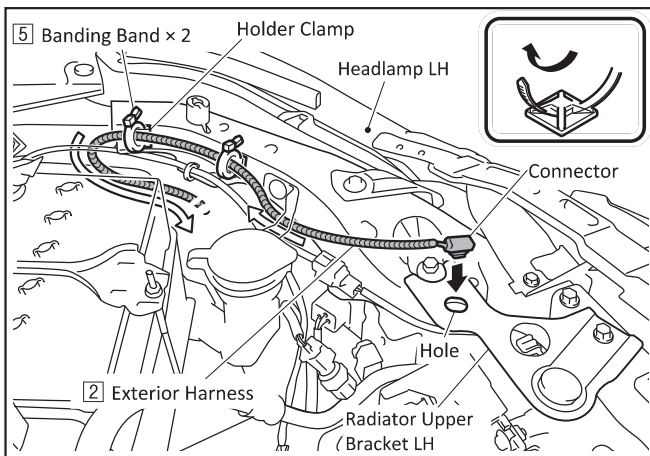

TG-ZW-B08

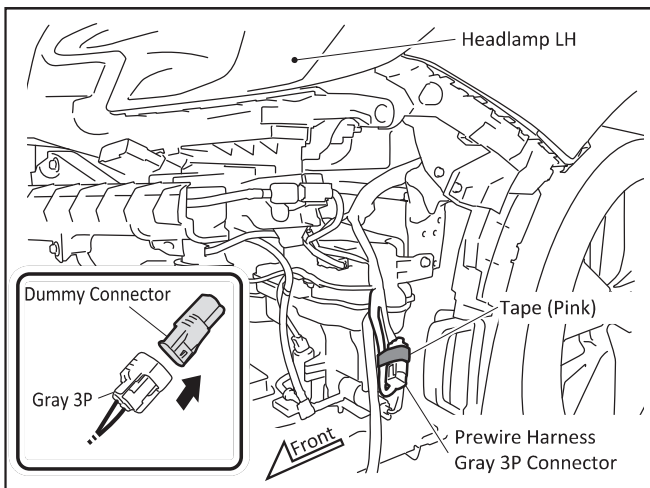

TG-ZW-B07

4. Installing the Exterior Harness

- (1) Clean the position to install the Holder Clamp (shaded area in the figure) for the FRAME RADIATOR UPPER SIDE LH with Degreaser.
- (2) Install the Holder Clamps (2 pcs) on the position to install the Holder Clamp (shaded area in the figure).
- (3) Secure the exterior harness connector to the Radiator Upper Bracket LH hole.
- (4) Layout the exterior harness to the underside of the Headlamp LH and secure to the Holder Clamp with Banding Bands (2 pcs).

- (5) Peel off the pink tape wrapped around the vehicle harness and pull out the Prewire Harness.
- (6) Detach the dummy connector from the gray 3P connector on the Prewire Harness.

NOTE

The detached Dummy Connector will be reused in the section, "<Installing the LED Emblem by Itself> on the next page.

<When installing the LED Emblem with the LED accessory liner>

Return the dummy connector to the customer.

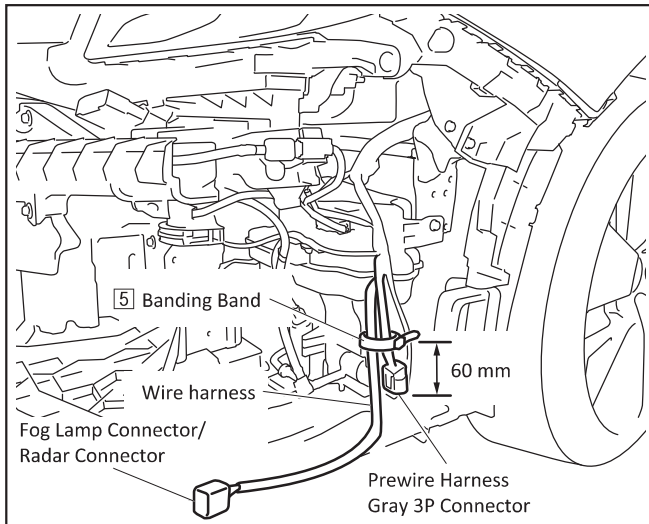

TG-ZW-B09

(7) In accordance with the dimensions in the figure, secure the prewire harness to the vehicle harness with Banding Band.

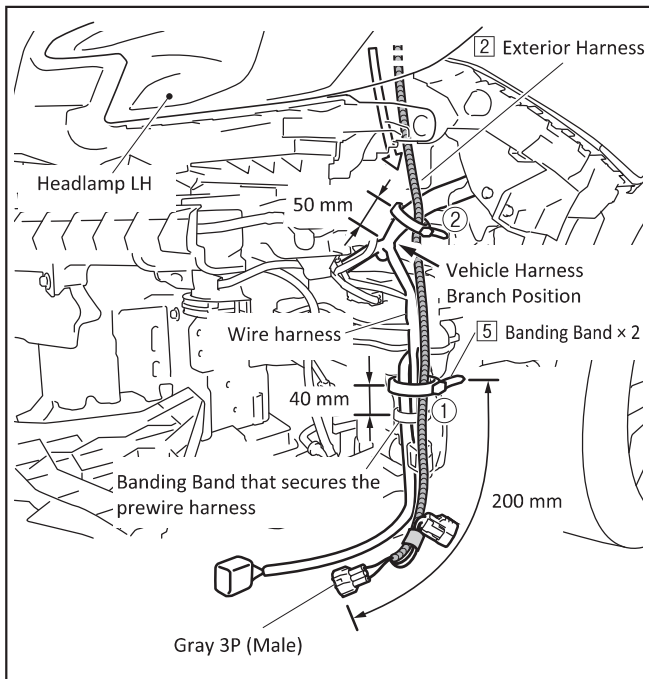

TG-ZW-B10

(8) In accordance with the dimensions and numbers in the figure, secure the exterior harness to the vehicle harness with Banding Bands (2 pcs).

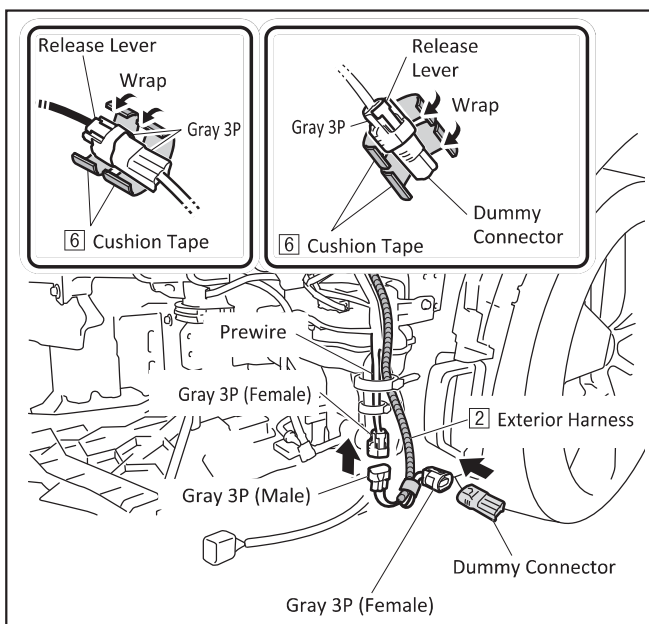

TG-ZW-B11

<Installing the LED Emblem by Itself>

- (1) Connect the gray 3P connector (male) on the exterior harness to the Gray 3P connector on the prewire harness (female) and then wrap Cushion Tape around it.
- (2) Connect the gray 3P connector on the exterior harness (female) to the Dummy Connector that you detached and then wrap Cushion Tape around it.

⚠ CAUTION

Wrap Cushion Tape around the connector ensuring that you can see the Release Lever.

👉 NOTE

Peel off and use one piece at a time of Cushion Tape along the cut line.

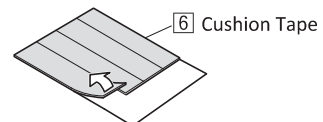

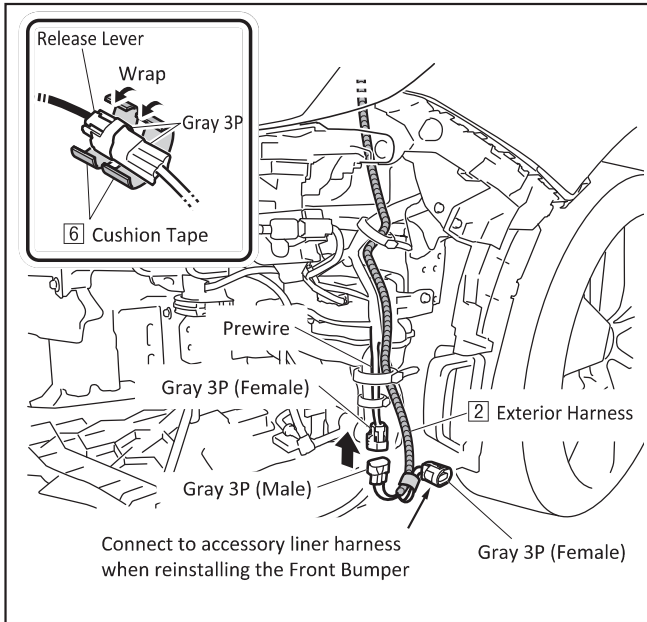

TG-ZW-B12

<Installing the LED Emblem with the LED Accessory Liner>

- (1) Connect the Gray 3P connector (male) on the exterior harness to the Gray 3P connector on the prewire harness (female) and then wrap Cushion Tape around it.

⚠ CAUTION

Wrap Cushion Tape around the connector ensuring that you can see the Release Lever.

👉 NOTE

- (1) Peel off and use one piece at a time of Cushion Tape along the cut line.

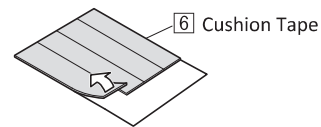

- (2) Connect the Gray 3P connector (male) on the exterior harness to the Gray 3P connector (female) on the LED accessory liner harness reinstalling the Front Bumper.

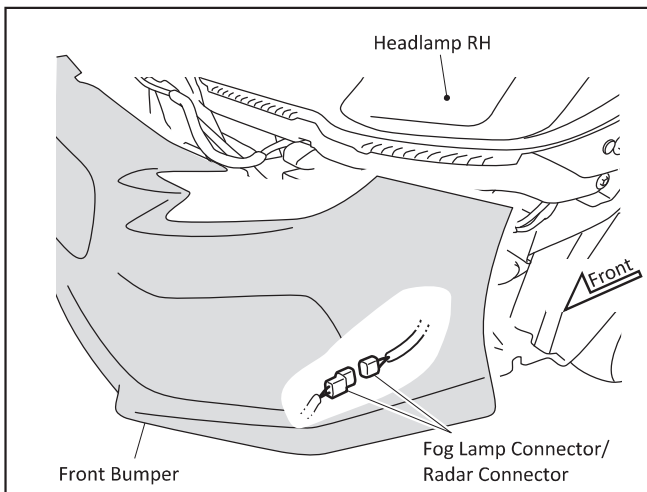

TG-ZW-C09

5.Connecting the Harnesses

<Installing the LED Emblem by Itself>

- (1) Bring the Front Bumper close to the vehicle, and then connect the Fog Lamp Connector/Radar Connector.

⚠ CAUTION

Check the orientation of the Fog Lamp Connector/Radar Connector and insert it until it makes a clicking sound. The fog lamps will not turn on if the connector is not connected correctly.

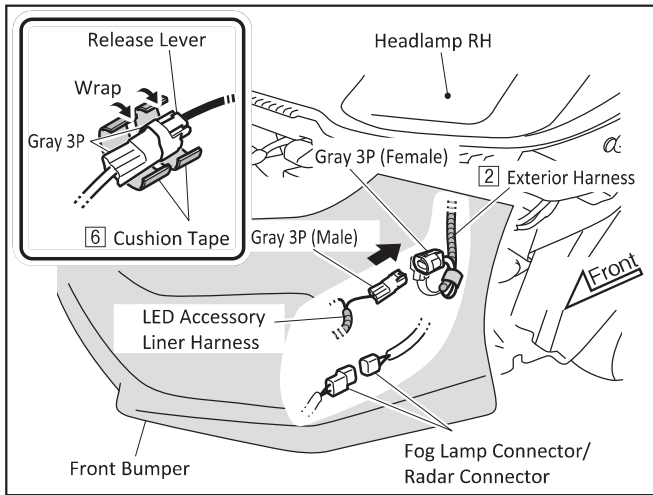

TG-ZW-C08

<Installing the LED Emblem with the LED Accessory Liner>

- (1) Bring the Front Bumper close to the vehicle, and then connect the Fog Lamp Connector/Radar Connector.

⚠ CAUTION

Check the orientation of the Fog Lamp Connector/Radar Connector and insert it until it makes a clicking sound. The Fog Lamps will not turn on if the connector is not connected correctly.

- (2) Connect the Gray 3P connector (male) on the LED Accessory Liner Harness to the Gray 3P connector on the exterior harness (female) and then wrap Cushion Tape around it.

⚠ CAUTION

Wrap Cushion Tape around the connector ensuring that you can see the Release Lever.

👉 NOTE

- (1) Peel off and use one piece at a time of Cushion Tape along the cut line.

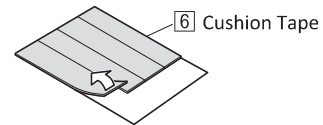

- (2) If the prewire Gray 3P connector (female) is already wrapped with urethane foam when installing the LED accessory liner, you do not need to perform this procedure of wrapping Cushion Tape around the Gray 3P connector on the prewire harness (female).

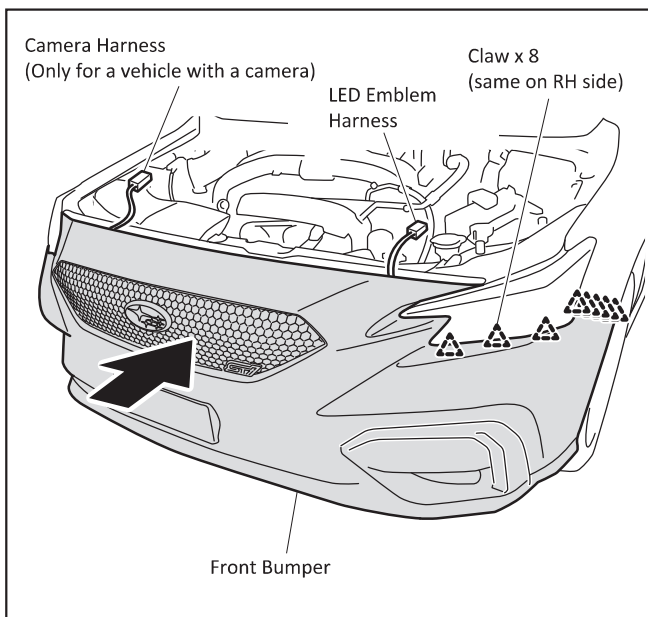

TG-ZW-C01

6.Reinstalling the Front Bumper (1)

- (1) Engage the Claws (16 places) and reinstall the Front Bumper.

⚠ CAUTION

- (1) Check that the Front Bumper Claws are set in the correct position before pushing them in to engage them. Not doing so may damage the Front Bumper.
- (2) For vehicles with a camera, face the Camera Harness toward the engine room so that you will be able to connect it.

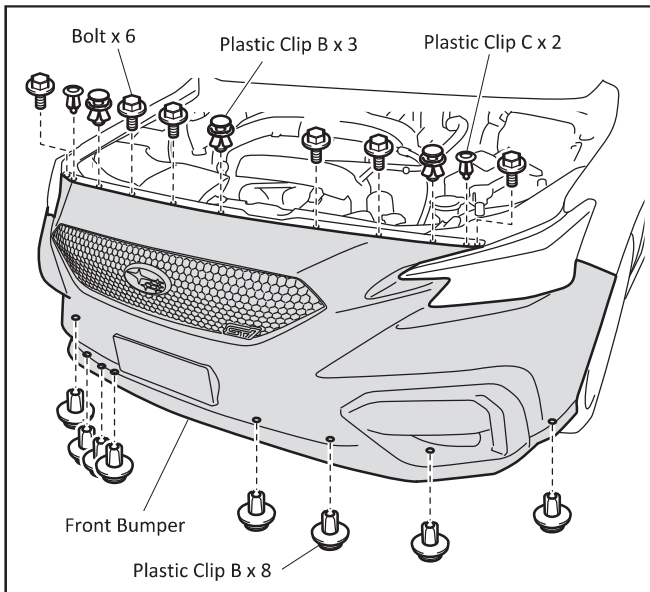

TG-ZW-C02

- (2) Secure the Front Bumper with the Bolts (6 pcs), Plastic Clip B (top: 8 pcs) (bottom: 3 pcs), and Plastic Clip C (2 pcs).

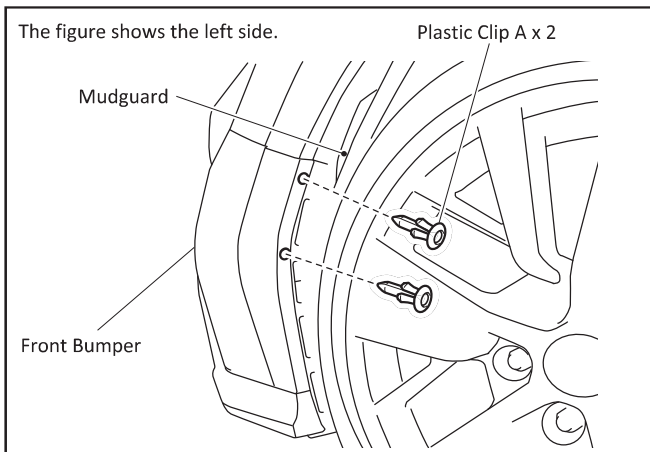

TG-ZW-C03

- (3) Secure the Front Bumper with Plastic Clip A (2 pcs).
 (4) Repeat the same procedure for the right side.

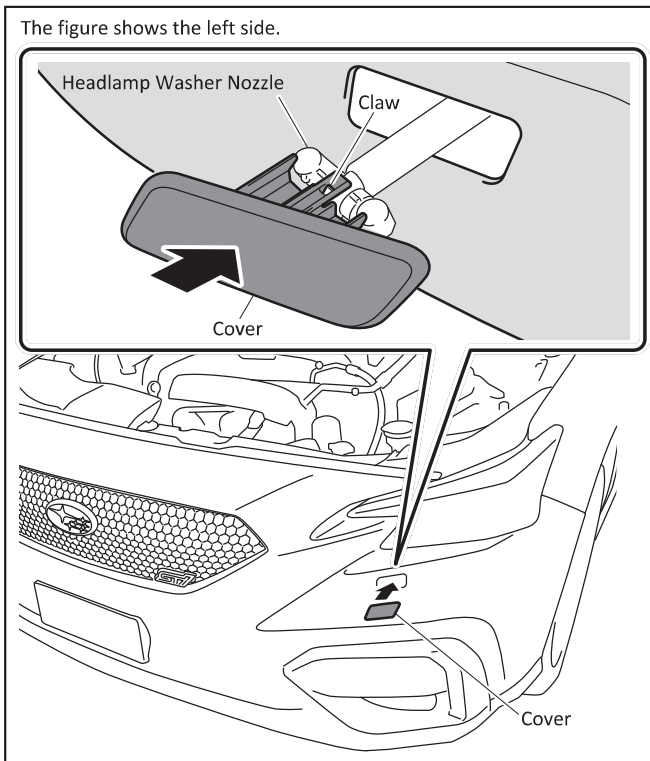

TG-ZW-C04

- (5) With the Head Lamp Washer Nozzle pulled out, engage the Claw, and attach the Cover.
 (6) Repeat the same procedure for the right side.

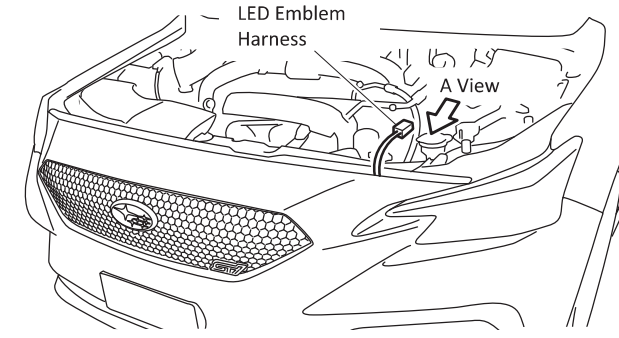
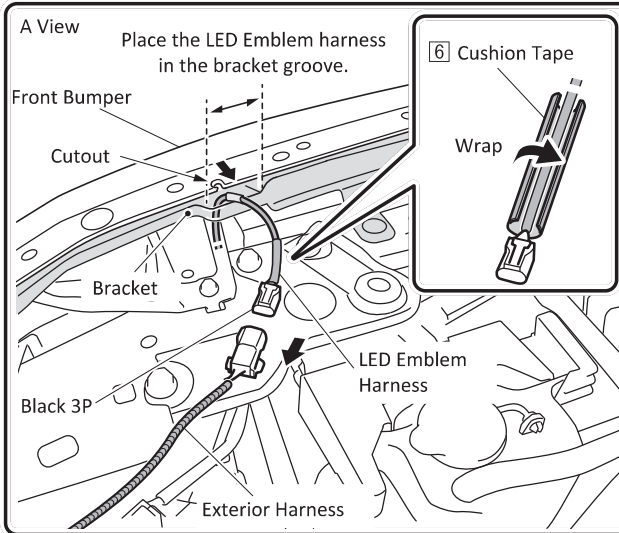

TG-ZW-C05

7.Connecting the LED Emblem Harness

- (1) Remove the LED Emblem harness from the cutout in the Front Bumper.
- (2) Wrap Cushion Tape around the LED Emblem Harness.

NOTE

Peel off and use one piece at a time of Cushion Tape along the cut line.

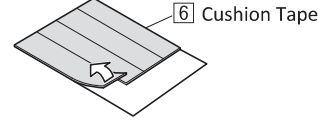

- (3) Connect the Black 3P connector on the LED Emblem Harness to the exterior harness.

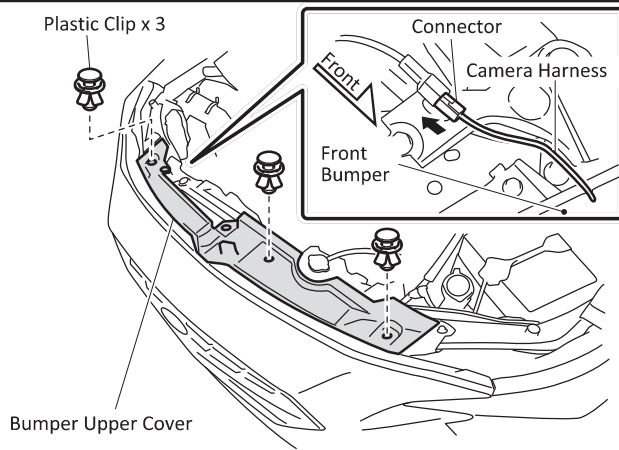

TG-ZW-C06

8.Reinstalling the Front Bumper (2)

- (1) Connect the camera harness connector.
- (2) Install the Bumper Upper Cover with the Plastic Clips (3 pcs).

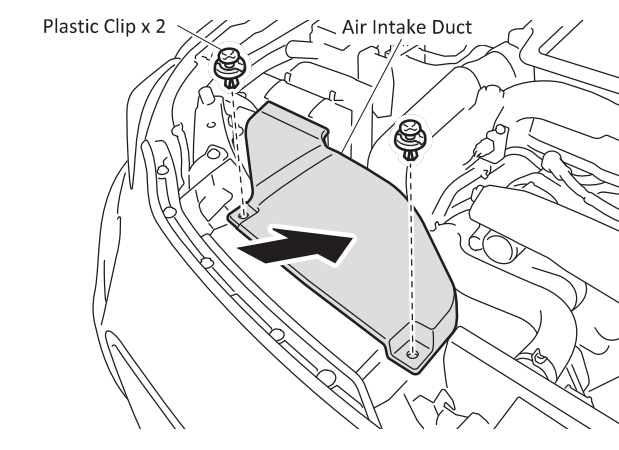

TG-ZW-C07

- (3) Install the Air Intake Duct with the Plastic Clips (2 pcs).

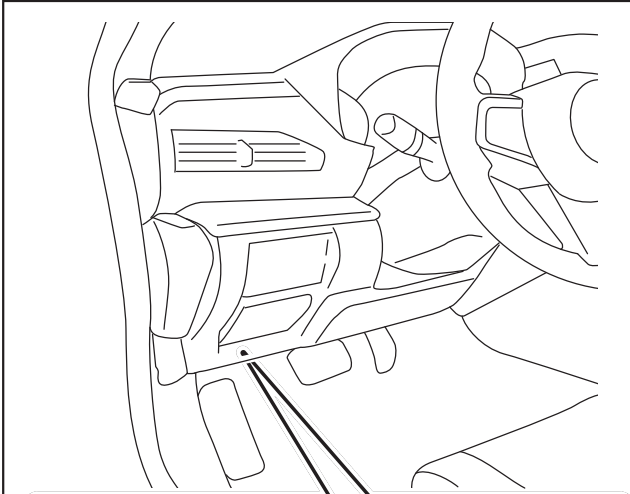

9. Wiring Inside the Cabin

- (1) Pull out the White 2P connector on the prewire from the vehicle harness at the back of the Fuse Box.
- (2) Connect the White 2P connector on the Cabin Harness to the white 2P connector on the prewire.

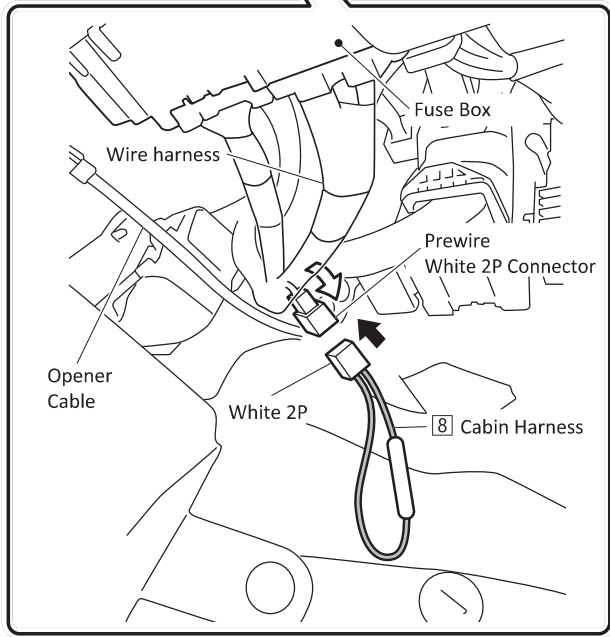

TG-ZW-D01

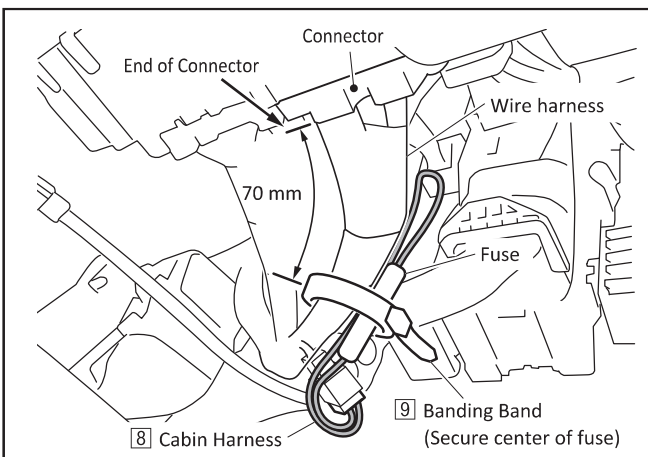

TG-ZW-D02

- (3) In accordance with the dimensions in the figure, secure the vehicle harness to the Cabin Harness with a Banding Band (1 pc).

⚠ CAUTION

Secure the center of the fuse with a Banding and.

Post-installation Inspection (Vehicle)

⚠ CAUTION

- (1) Check that the fog lamps turn on.
- (2) Check that the camera images are displayed correctly on the multifunction display.
- (3) Re-check that the plastic clips and bolts are not loose and the parts are properly secured.
- (4) Remove all protective tape.

Post-installation Inspection (LED Emblem)

- (1) Temporarily connect the battery and return the gear stick position to parking.
Putting the ignition or start switch to the ignition (IG) position will turn on (light up) the LED Emblem.
- (2) Fully tighten the minus terminal on the battery, check that all parts that you uninstalled and reinstalled function correctly, set the audio, clock, and anything else that was preset, and wash the car. This now ends the operation.

Circuit diagram

Installing the LED by itself

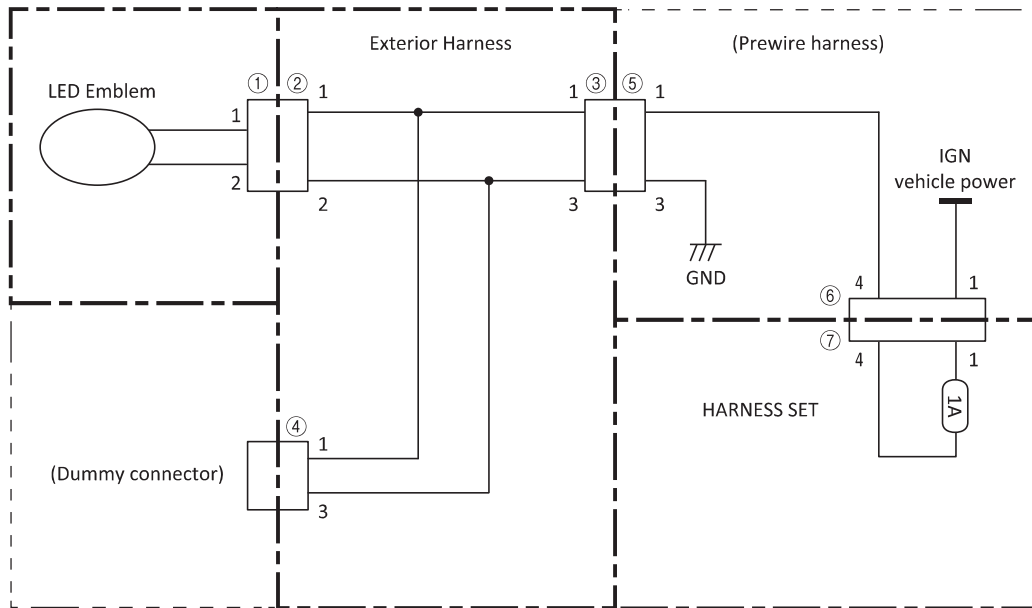

Installing with the LED accessory liner

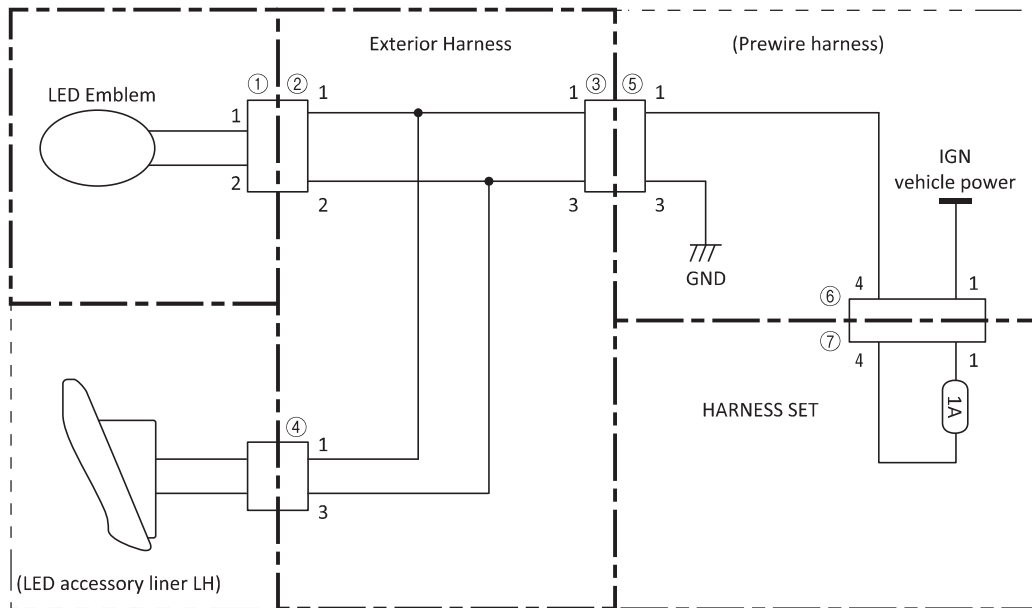

①



(Female)

②



(Male)

③



(Male)

④

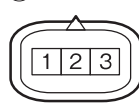

(Female)

⑤

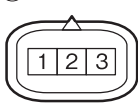

(Female)

⑥

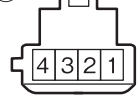

(Male)

⑦

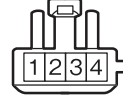

(Female)

Revision History

Revision	Revision Date	Revision details