

Kit Contents:

A. Amplifier with Bracket (1)

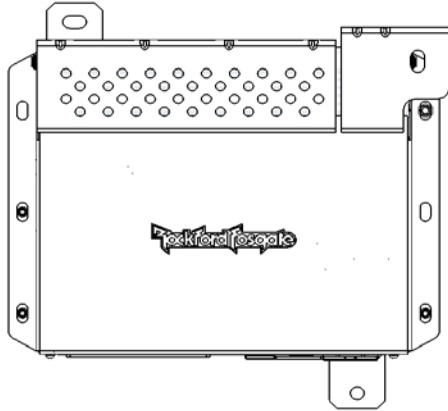

D. Badge (2) with push nuts (4)



E. Clip



B. Harness (1)

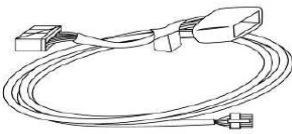

C. Cable tie (8)



F. Mounting Hardware (2)

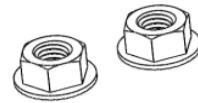

G. Replacement Speaker (2)

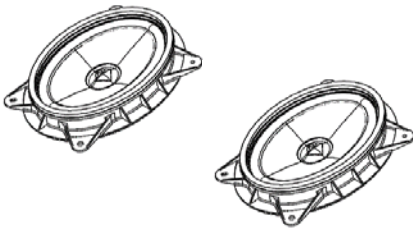

H. HVAC Duct extension (2)

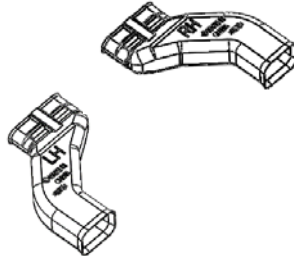

**IMPORTANT:**

1. The installation should be carried out by an authorized Subaru Dealer.
2. Pay special attention not to damage vehicle components when removing/installing them.
3. Route the wiring so that it cannot be abraded against any sharp edges.

Tools Required:

- Phillips screwdriver
- Forked Trim Tool
- Wide Trim Tool
- 10mm Nut Driver
- 10mm Wrench
- Torque Wrench with 10mm socket

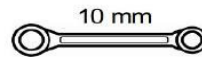
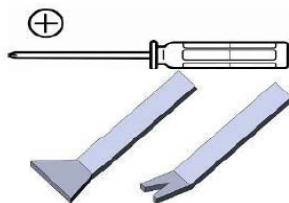

Meaning of Characters:

- ← Remove / Déposer
- ↶ Install / Poser

- ↔ Connect / Connector
- ⊙ Location of clip or screw  
Emplacement de l'attache ou de la vis

VERSION	DATE	SUBARU OF AMERICA	PAGE
1.0	2016-11-15		1 / 12

1. Overview of system component locations and harness routing.

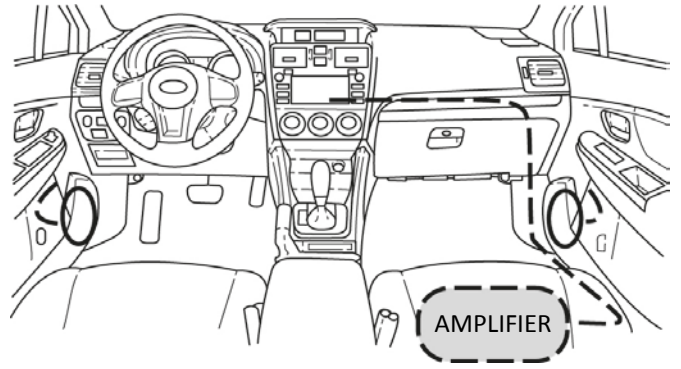

2. Disconnect Negative (-) battery cable.

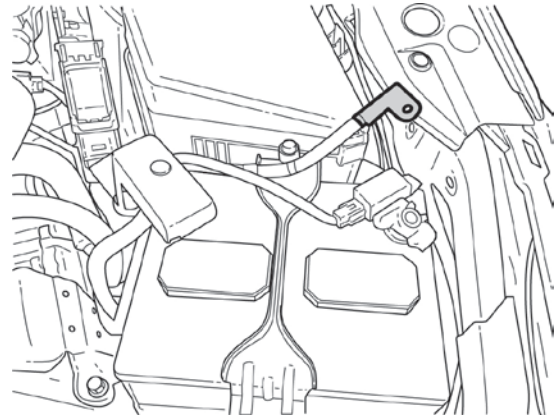

3. Remove A/C Vent panels on either side of the radio.

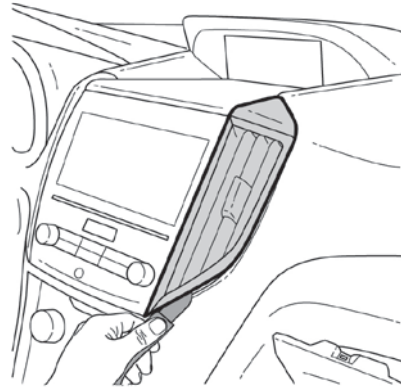
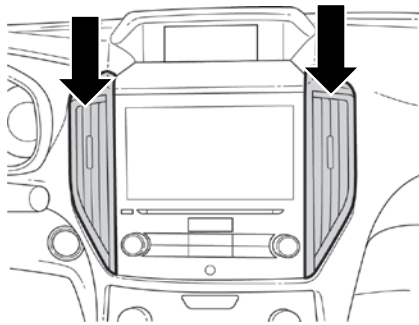

4. Remove trim panel above radio. Please use care --- the clips are very tight.

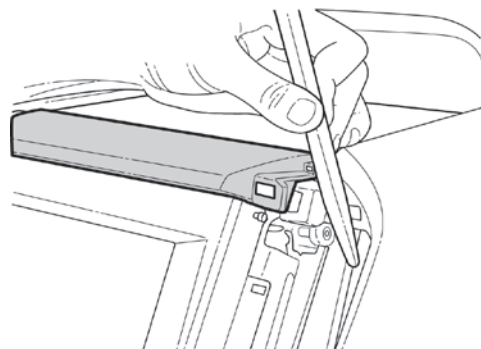
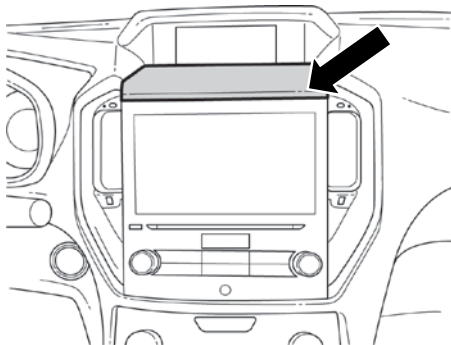

5. Remove (4) Philips screws.

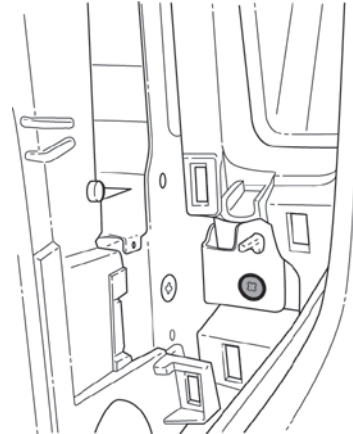
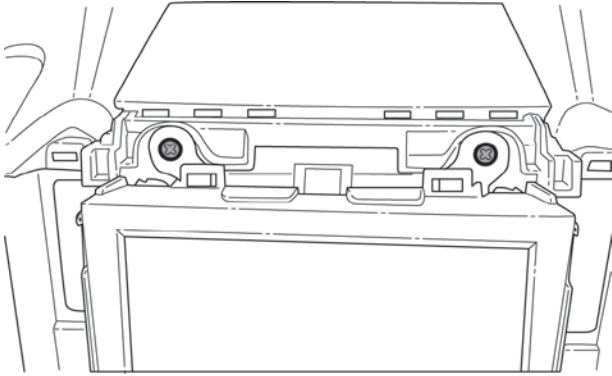

6. Pull radio away, carefully unplug connectors from radio and telematics module and set assembly aside.

**NOTE:**

Place a protective cloth over the dash and gear shifter to protect the surfaces from being scratched by the radio brackets.

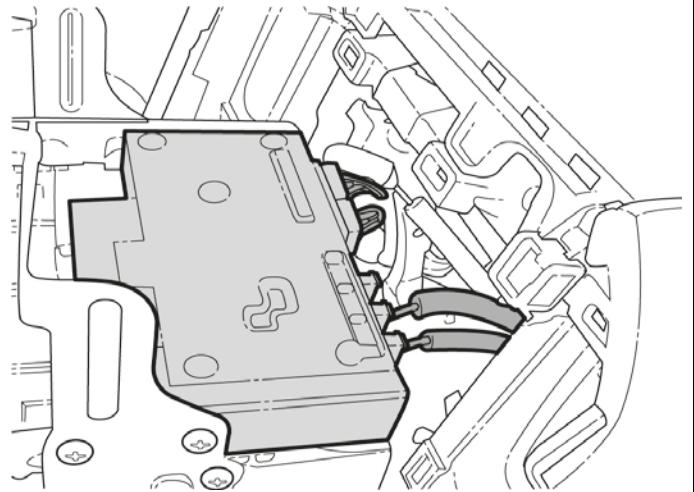

7. Remove trim panels above and to the right of glove box door.

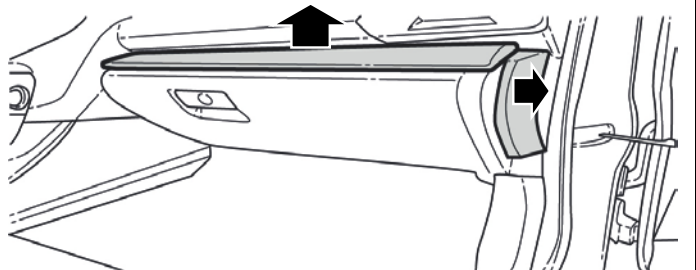

8. Remove glove box door.

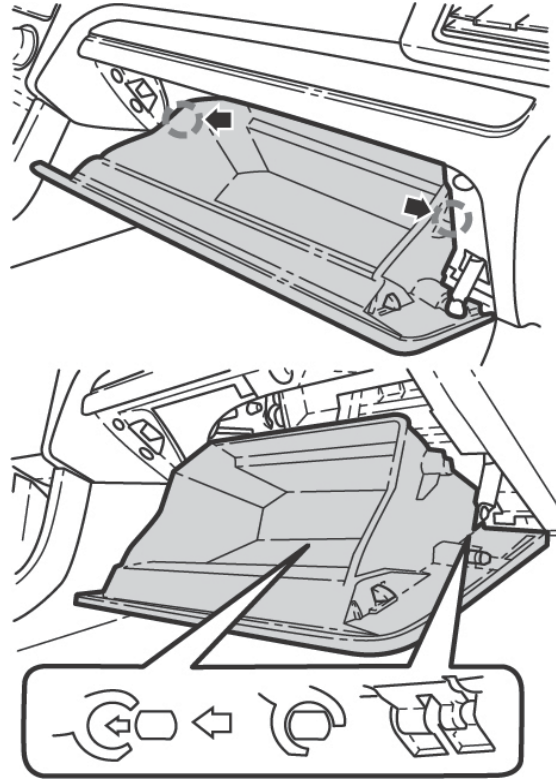

9. Remove glove box panel by removing (7) screws. Make sure to disconnect the glove box light.

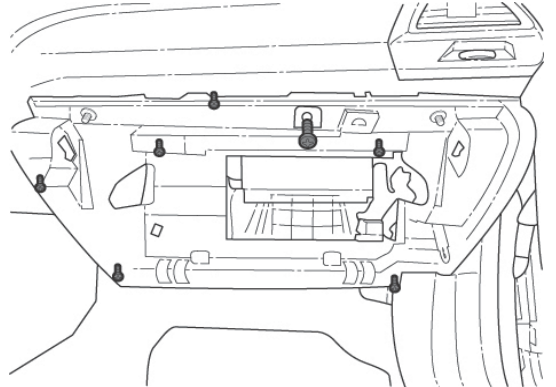

10. Remove PASSENGER side scuff plate. Note clip locations.

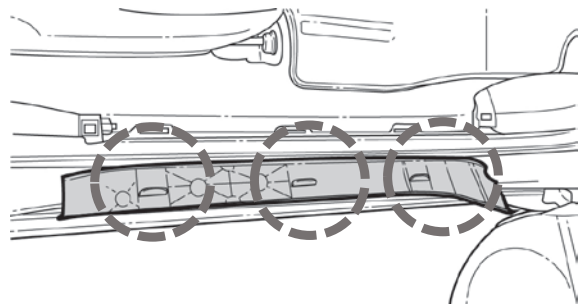
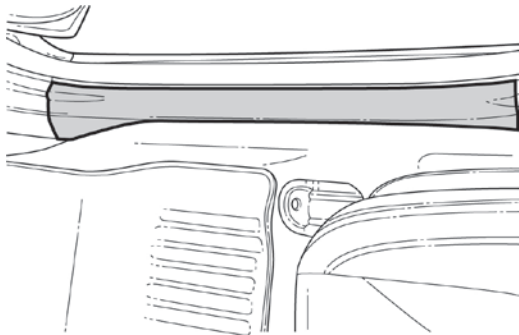

11. Remove PASSENGER kick panel

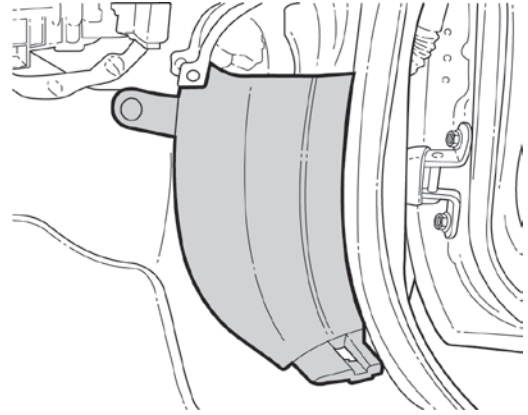

12. Loosen B-pillar by prying lower clip away from car.

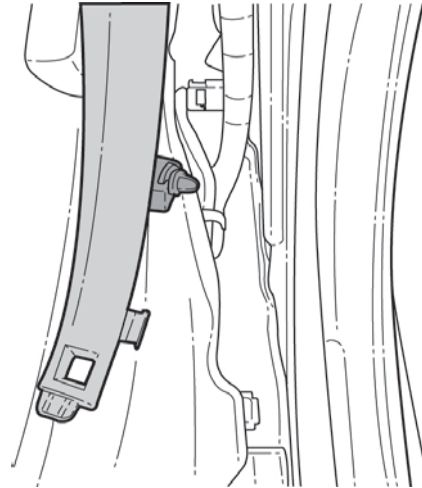
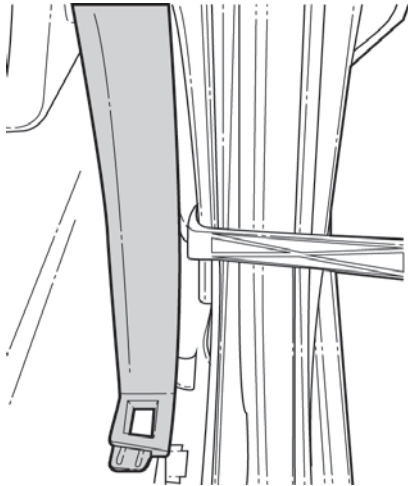

13. Route adapter harness from radio opening into glove box as shown. Align foam tape with metal bracket.

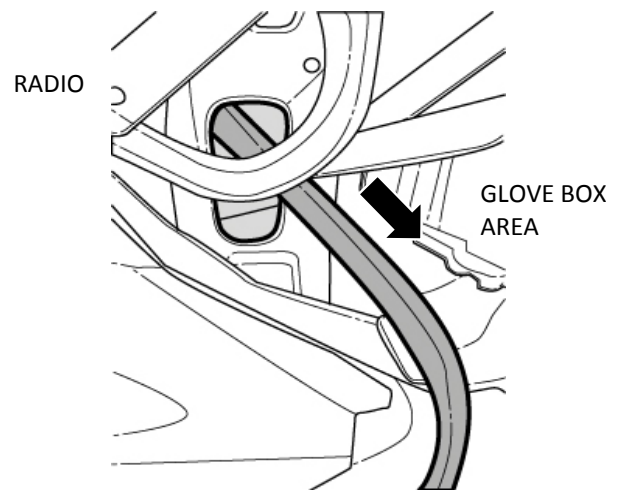

14. Align foam tape with opening in metal bracket.



15. Route wire as shown. White tape marks should line up with 5 highlighted wire tie locations. Secure the harness with 5 wire ties

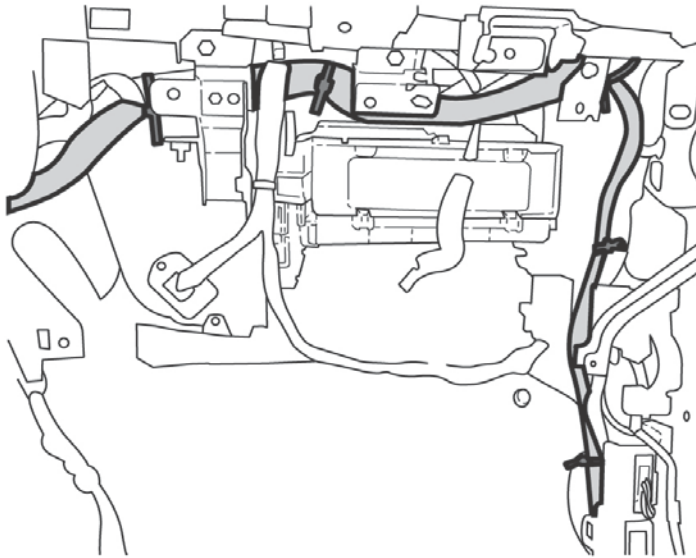

16. Route wire down behind tan-colored connector junction aligning the foam tape as shown.

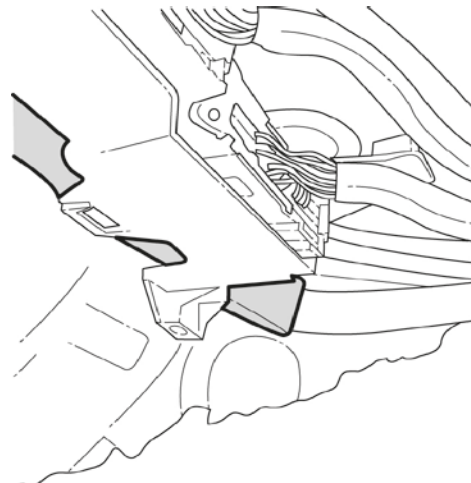

17. Route wire along door seal and place inside first two wire clamps. Open clip by sliding the top-side of the clip in the direction indicated.

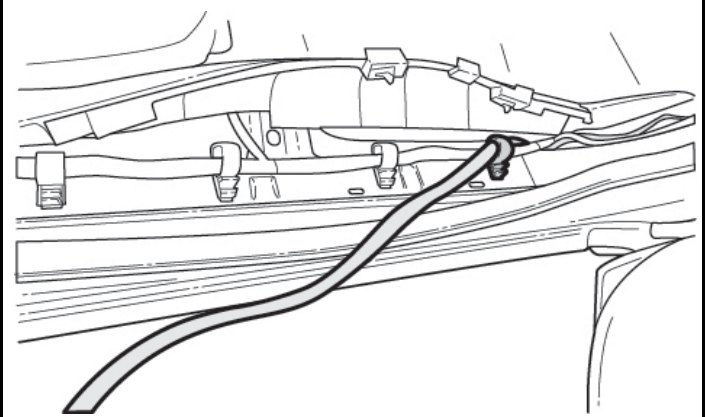
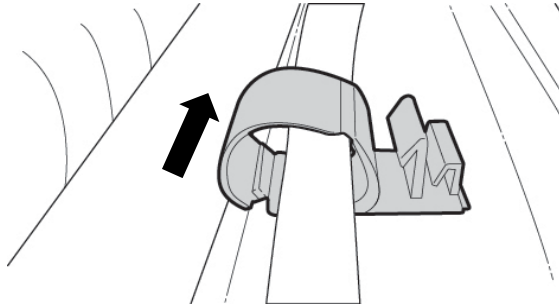

18. Align tape mark as shown and secure with wire tie.

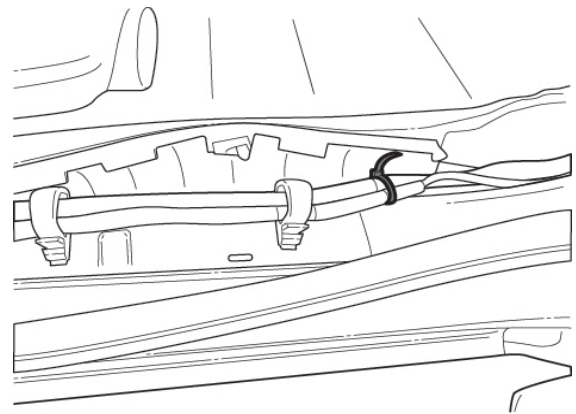

19. Feed wire under seat. Align last tape mark as shown and secure with wire tie.

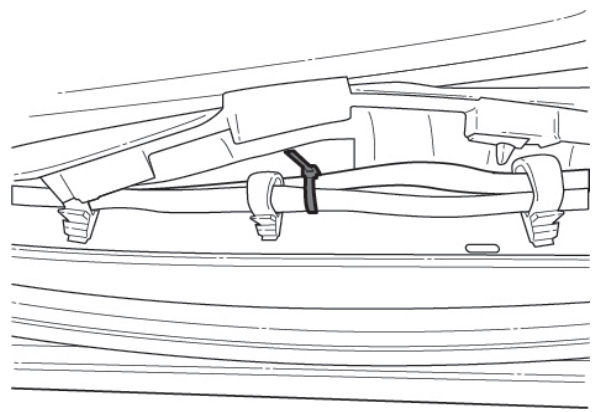

20. Install the two included HVAC duct extensions over the ductst under the front passenger seat. Note (L) / (R) duct orientation.

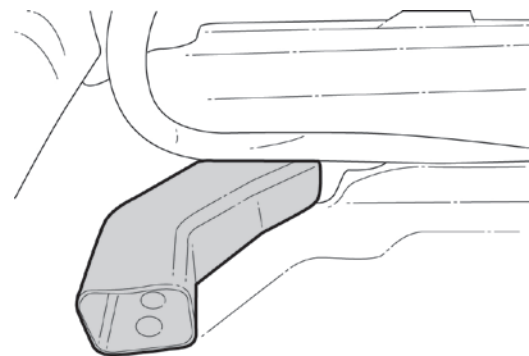
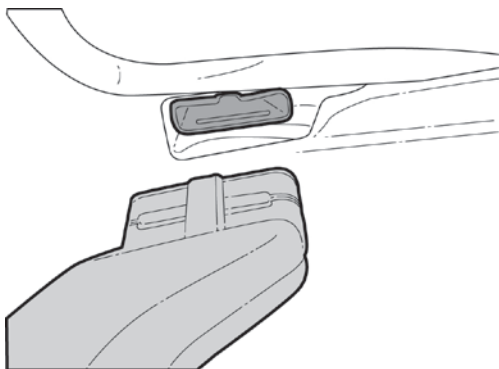

21. Amp wire harness should exit the carpet from the same hole as the right side vent (as highlighted).

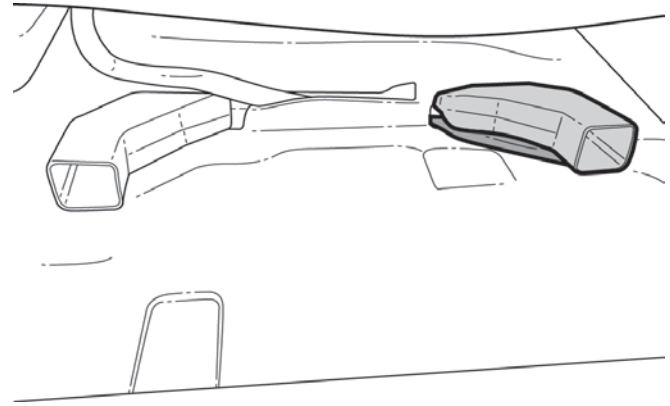

22. Place amplifier under seat aligning bracket with two threaded studs found under two relief cuts in carpet. Secure with two included nuts torqued to 7.5n/m (+/- 2). Connect harness to amplifier as shown.

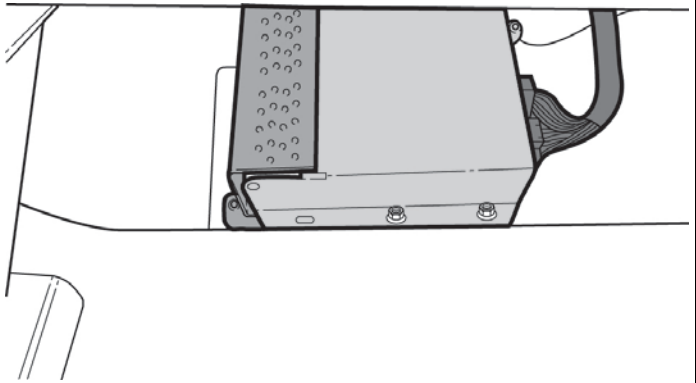

23. Secure seat harness to amp bracket with included clip as shown. Ensure clip is approximately 100mm from carpet exit as highlighted.

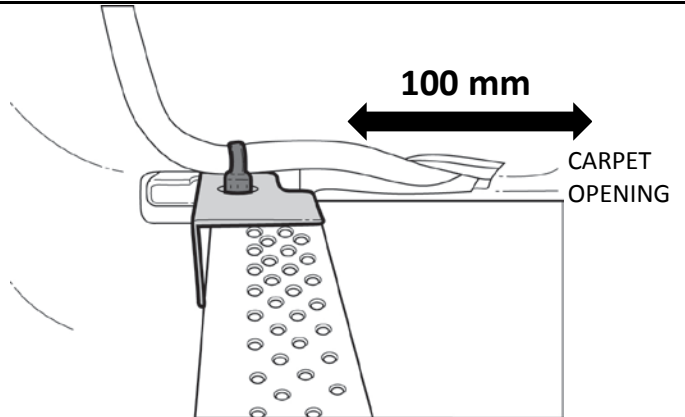

24. Make connections at radio location. Connect the 6-pin and 10-pin connector ends that are wrapped in foam to main two stock radio connectors. Connect the 2-pin connector to the pre-arranged 2-pin connector secured to the OEM Harness with blue breakaway tape.

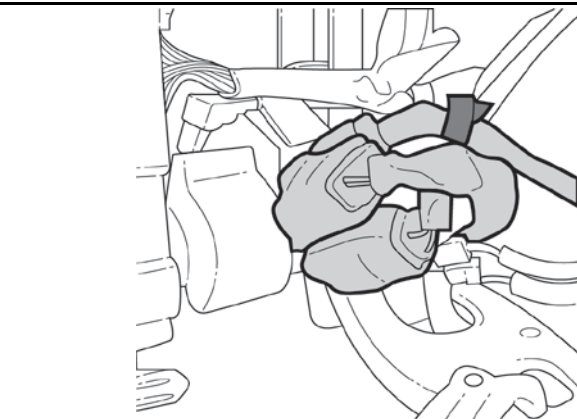



25. Connect adapter harness 6-pin and 10-pin connectors to headunit. Reconnect all remaining connectors to radio and telematics module. Reinstall the radio assembly, panels, and A/C vents to the dash in reverse order of removal.

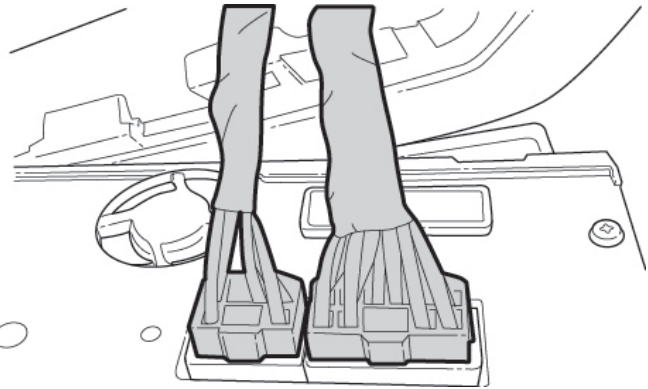

26. For speaker replacement, the front two door panels will need to be removed.

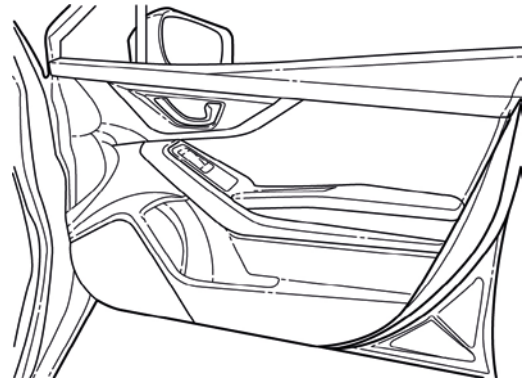

27. Use a small slotted screw driver to open screw cover. Remove screw.

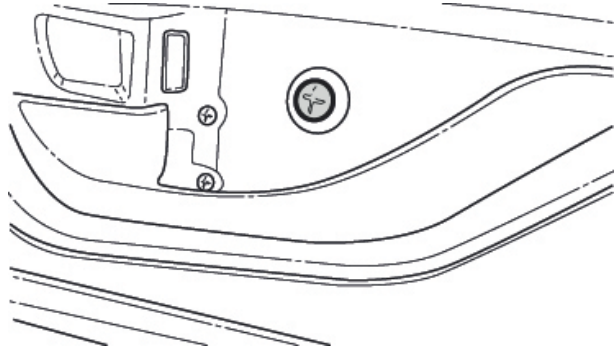
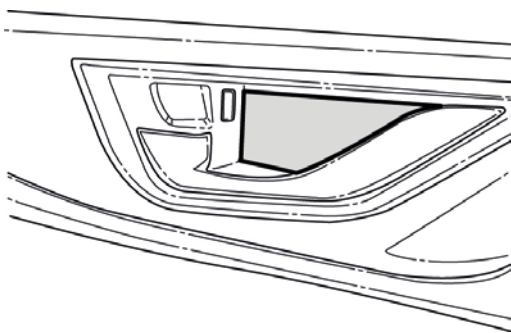

28. Inside the armrest pull handle, use a small slotted screw driver to open screw cover. Remove screw.

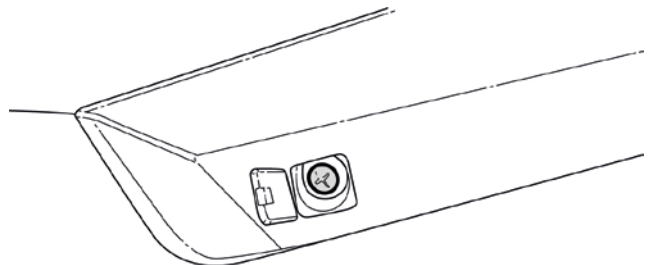

29. Remove trim at top corner of door panel.

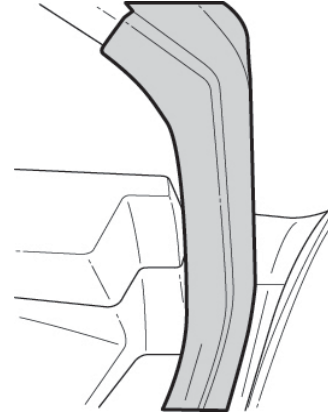

30. Pull out bottom of door panel. Lift up to release panel from door. Verify that none of the 8 clips remain in the door's sheet metal. If there are clips remaining in the sheetmetal, remove them and reinstall them at their locations in the plastic door trim panel.

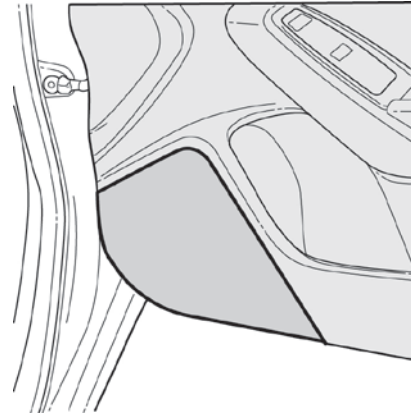

31. On the back side of the plastic door panel, unclip the door lock and door handle cables.

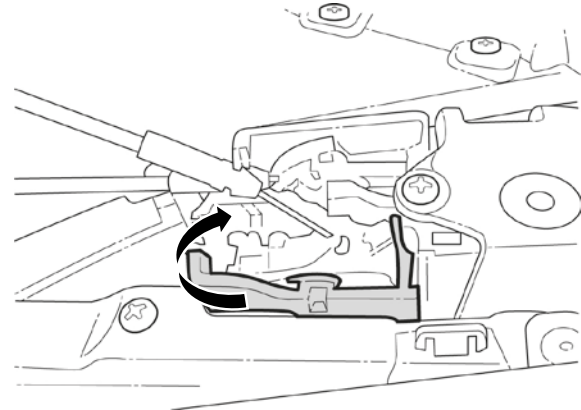

32. Remove all electrical connectors and carefully place door panel aside.

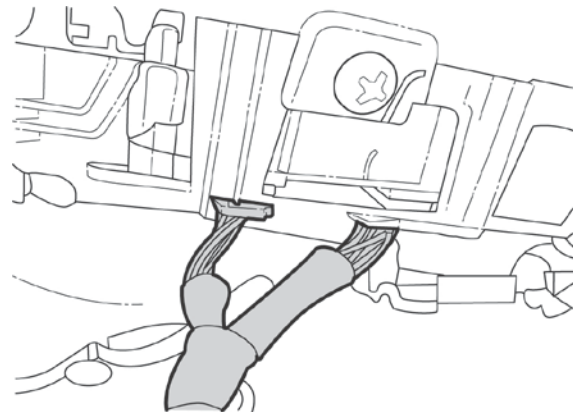

33. Disconnect speaker harness and remove (4) screws holding the speaker to the door. Remove the speaker and set aside.

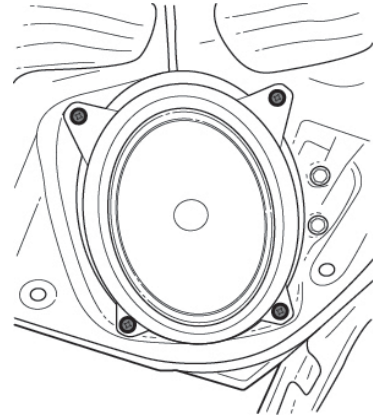

34. Carefully install new speaker using factory hardware and reconnect the speaker harness.

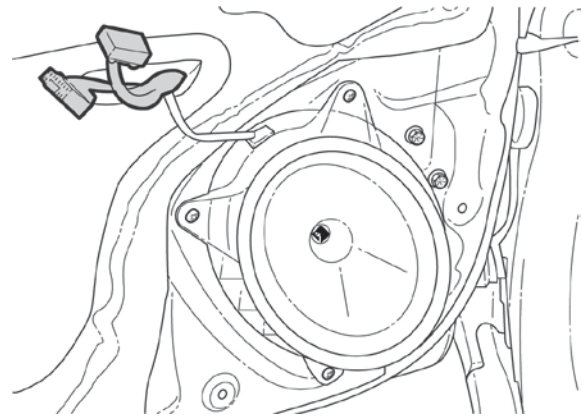

35. To install included Rockford Fosgate badges, locate the two pre-arranged mounting holes near the bottom inside edge of the speaker grille.

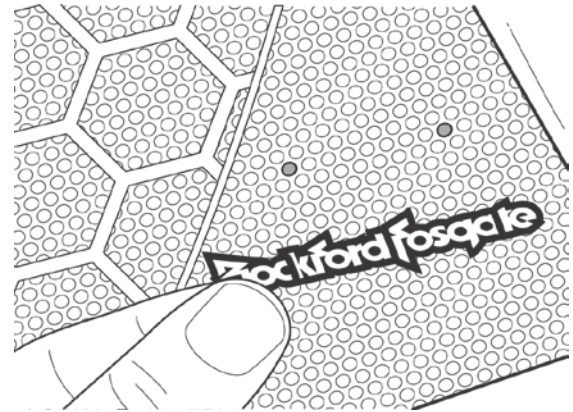

36. Remove masking on the backside of the badge. Position badge onto door panel.

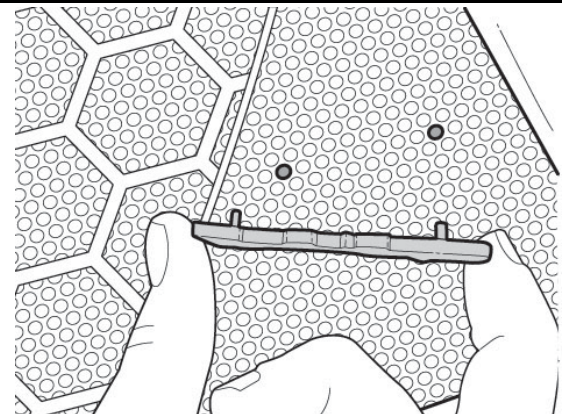
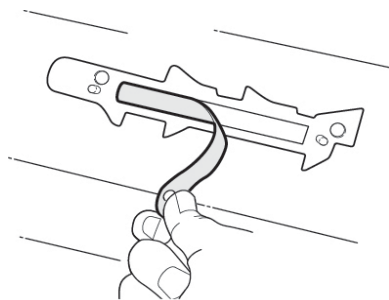

37. Attach badge by installing retaining rings to the posts on backside of door panel.

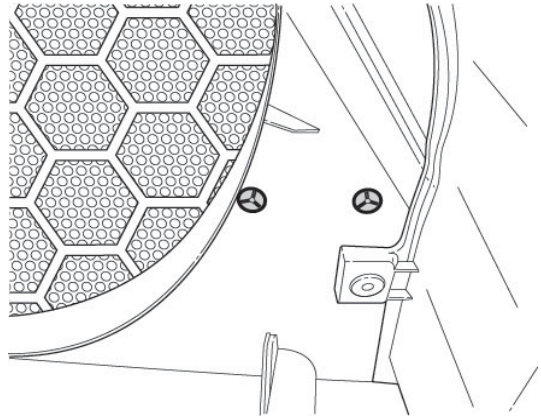
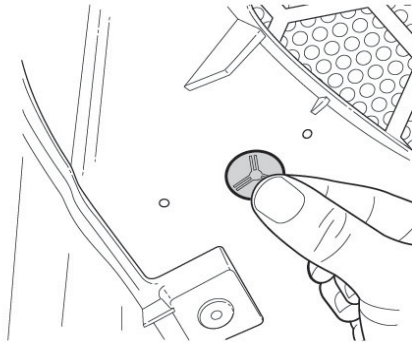

38. Reinstall door panels in reverse order and remove the masking on badge.

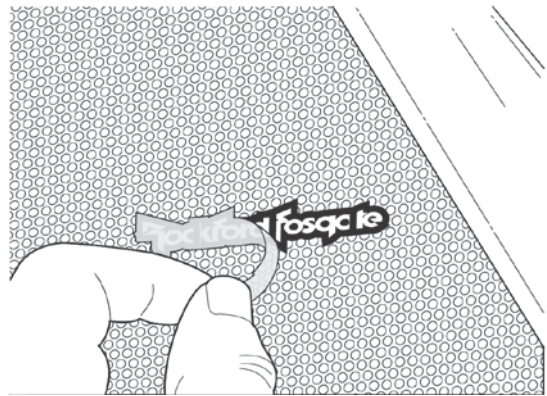

39. Reconnect battery and torque to 66 in.-lbs. Test audio system for sound at all speaker locations.

