



SUBARU

BRZ FOG LAMP KIT BRZ VOILEZ L'EQUIPEMENT DE LA LAMPE

INSTALLATION INSTRUCTION
GUIDE D'INSTALLATION

PART No. H4510CA150



USA : To technicians

IMPORTANT

1. The installation should be carried out by an authorized Subaru dealer.
2. Pay special attention not to damage vehicle components when removing / installing them.
3. Route the wiring so that it cannot be abraded against any sharp edges.
4. Refer to the vehicle service manual.
5. Check that the vehicle's electronic devices are operating normally. Be sure to make note of the contents of the memory of electronic devices such as the preprogrammed radio channels.

F : Aux techniciens

IMPORTANT

1. Nous recommandons de faire entreprendre le montage par un atelier Subaru. Aucune garantie n'est accordée en cas de montage défectueux.
2. Prendre particulièrement garde de ne pas endommager les éléments du véhicule lors du démontage ou remontage.
3. Bien acheminer les fils conducteurs de sorte que les arêtes tranchantes des panneaux de carrosserie, etc., ne provoquent pas de court-circuit.
4. Rapportez-vous aussi au manuel d'usage du véhicule.
5. Vérifier que les dispositifs électroniques du véhicule fonctionnent normalement. Assurez-vous de prendre note du contenu de la mémoire des appareils électroniques, tels que chaînes de radio préprogrammées.

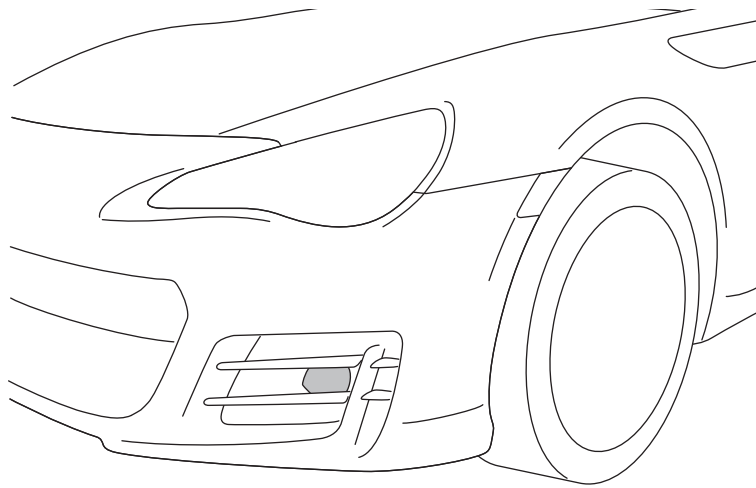

USA : Components
F : Éléments

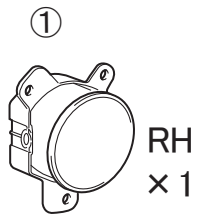

84501CA000

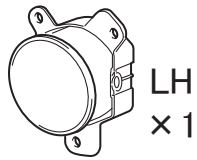

84501CA010

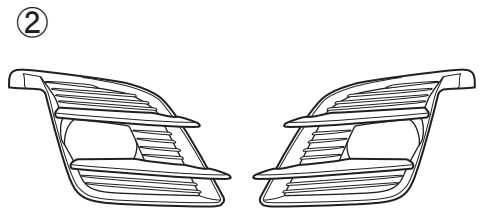

57731CA350

57731CA360

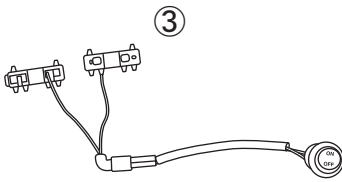

H4510CA120

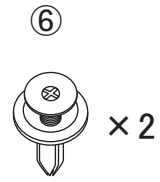
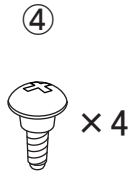

⑦

FOG LAMP

H4510CA130

USA : Tools
F : Outils

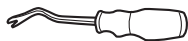

[+]



[-]



10mm



10mm

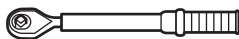

Ø20mm

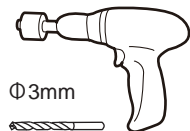

Ø3mm

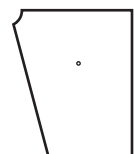
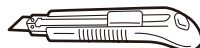

USA : Template
(the end of the book)
F : Modèle
(Fin du manuel)

1

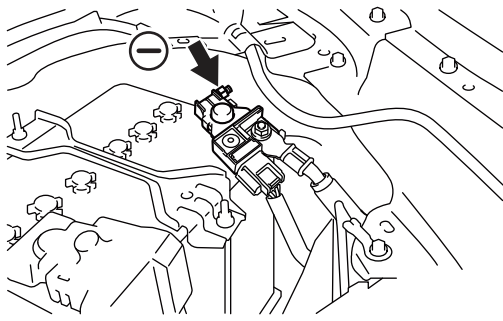

2

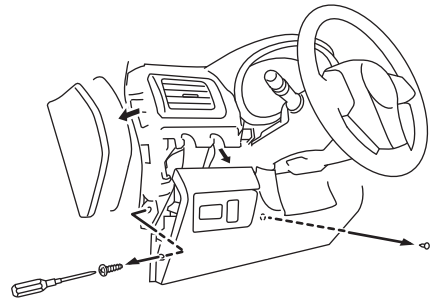

3

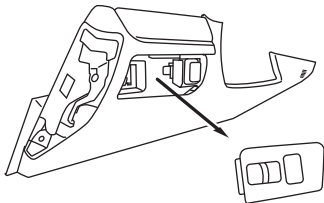

4

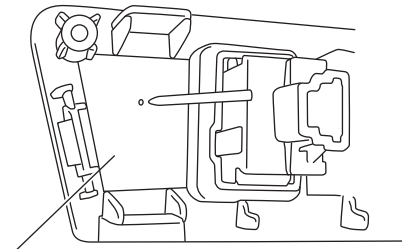

USA : Template at the end of the installation instruction

F : Le modèle à la fin du manuel

5

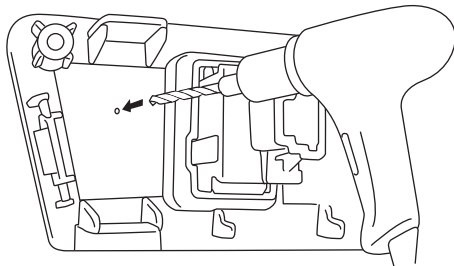

6

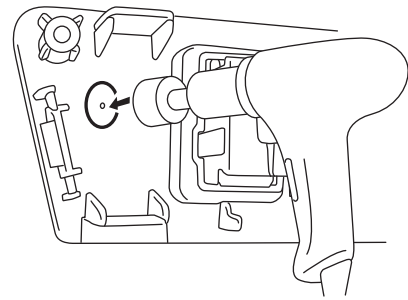

USA : Remove burs with a retractable knife.

F : Enlève Bali avec un couteau escamotable.

7

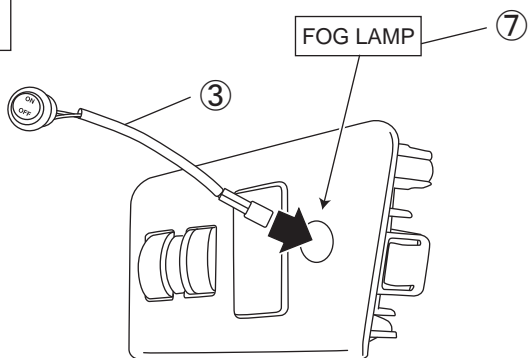

8

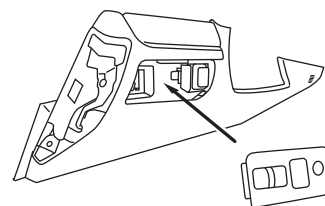

9

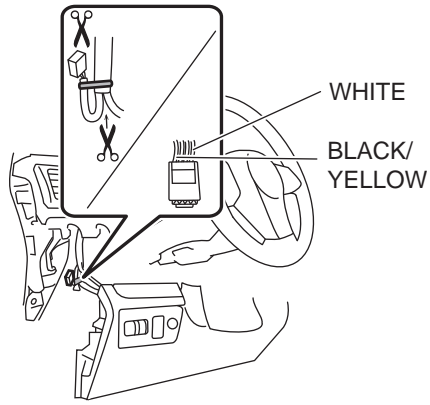

10

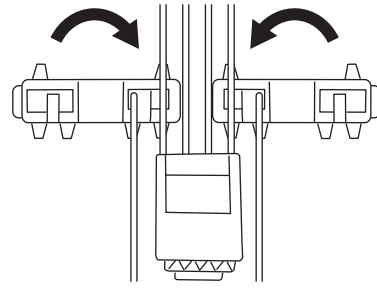

11

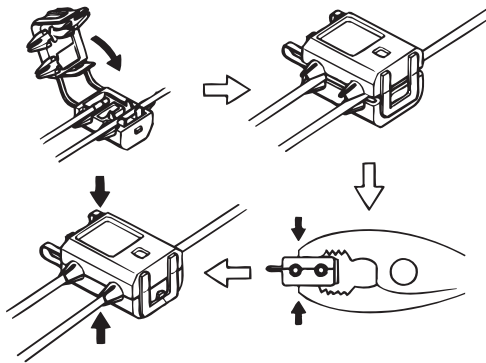

12

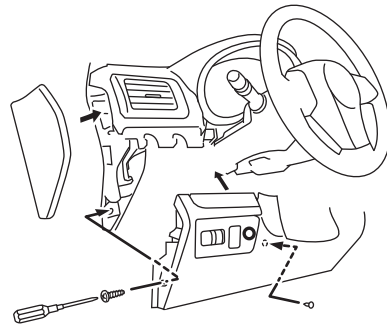

13

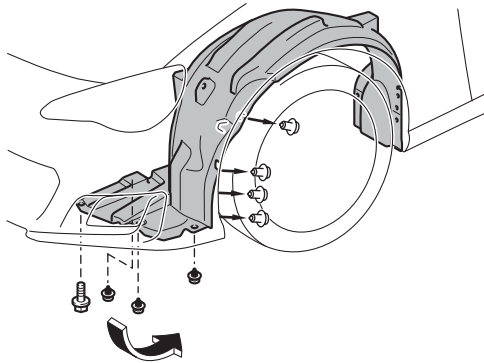

14

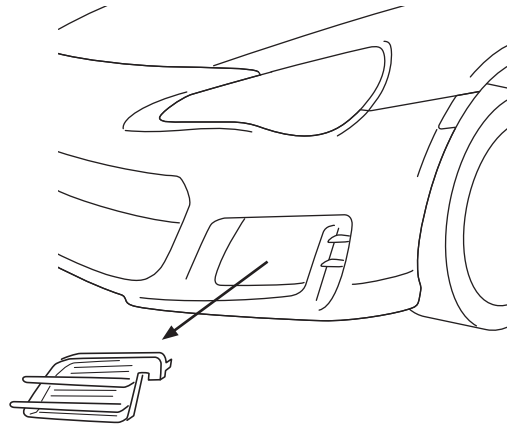

15

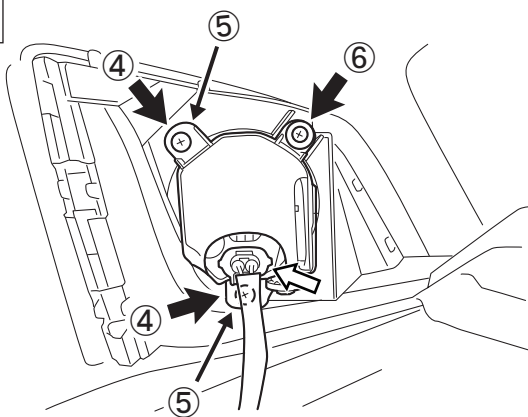

16

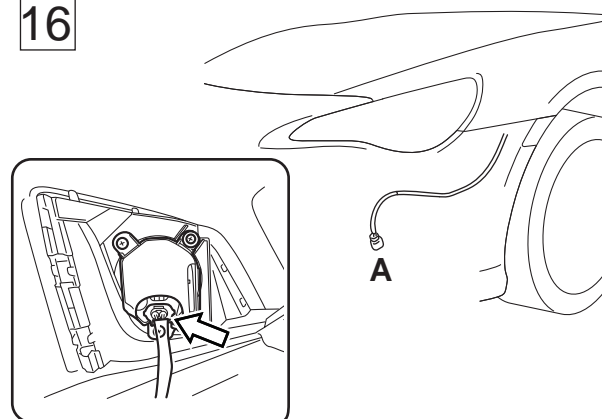

17

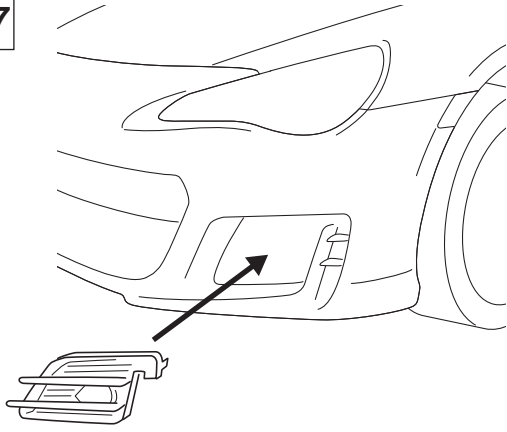

18

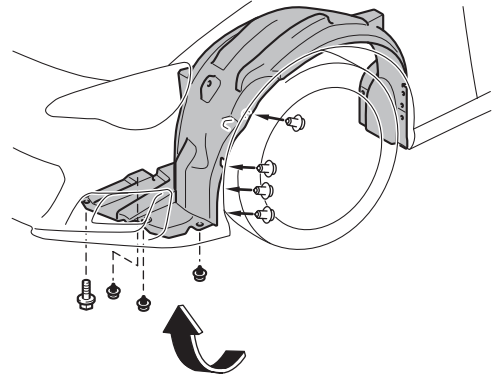

19

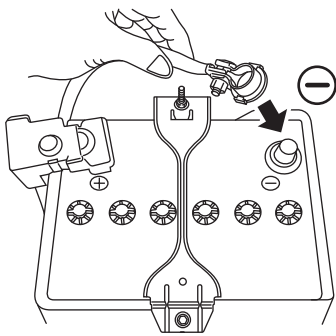

20

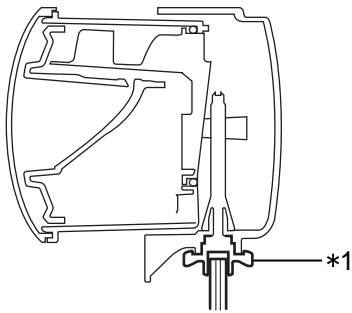

USA : Cut off line
 F : Ligne de coupure

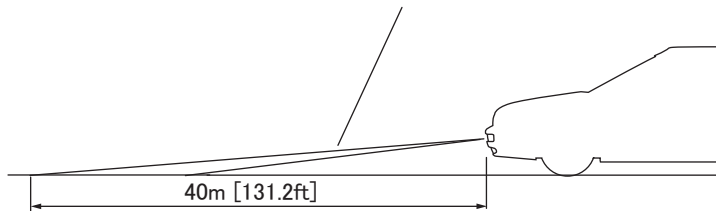

USA : Template
 F : Modèle

