

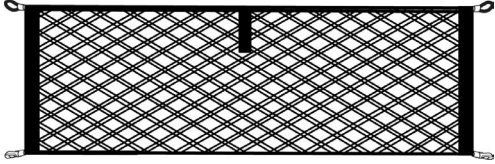

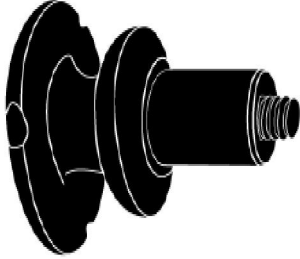







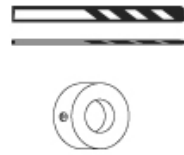



A	KIT CONTENTS:	B	2x	C	2x
					

TOOLS REQUIRED:





(1/2") 13mm Drill Bit
(1/4") 6mm Drill Bit
Drill Stop

Meaning of Characters:

-  : Remove
-  : Install
-  : Disconnect
-  : Connect
-  : Location of pre-arranged mark
-  : Driver side rear cargo area
-  : Passenger side rear cargo area
-  : Tightening Torque
-  : Loosen
-  : Discard
-  : Recyclable
-  : View

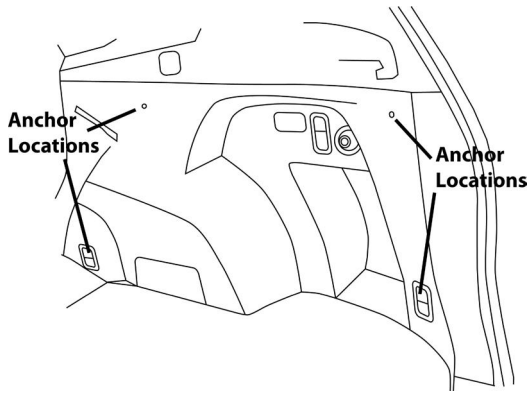

1 

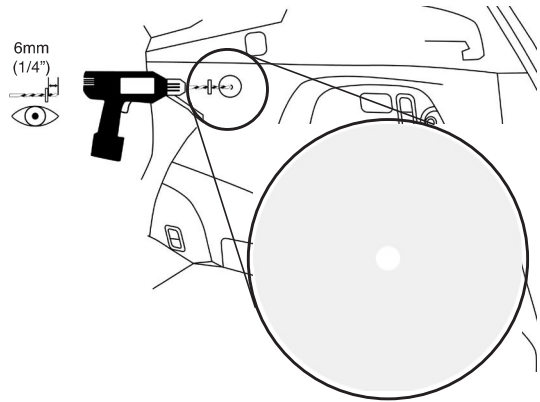

2 
 (1/4") 6mm



Note: Look for dimpled, untextured area.

3 
 (1/2") 13mm

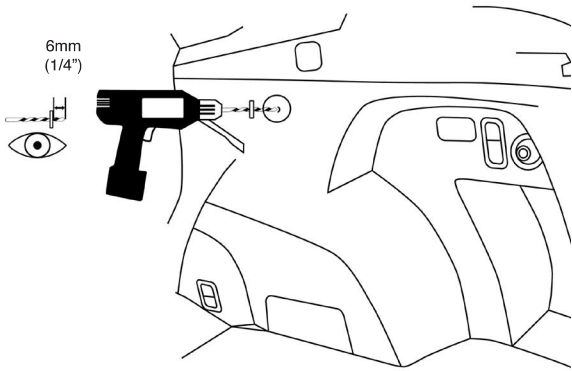

4 



Note: Spacer must be connected to mushroom assembly prior to installing into panel

4b



4c



Note: Hand tighten mushroom anchor into panel until snug

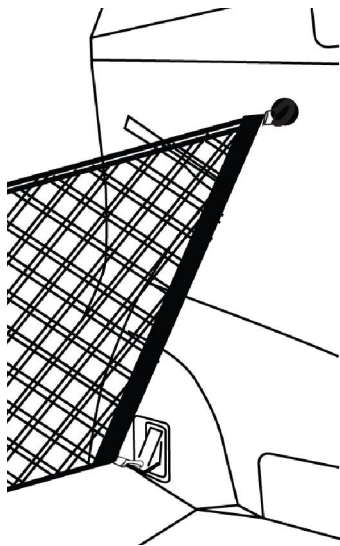

5 

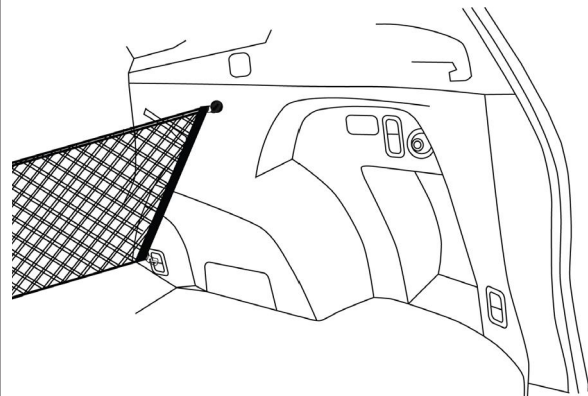

6 



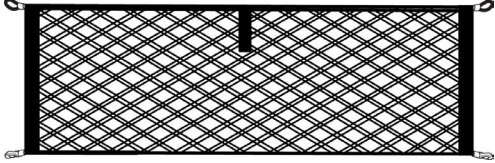
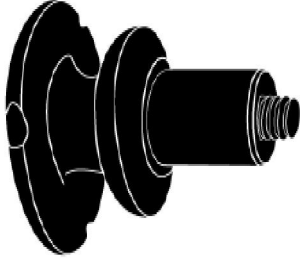



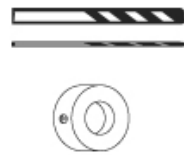





Note: Installation is identical for opposite side of vehicle.

A	CONTENU DU KIT:	B	C
		2x 	2x 

OUTILS REQUIS:

(Foret 1/2 pouces) 13mm
(Foret 1/4 pouces) 6mm
Limite de perceuse

Significations des caractères:

	: Retirer	T	: Couple de serrage
	: Installer		: Desserrer
	: Déconnecter		: Dégager
	: Connecter		: Recyclable
	: Emplacement de la marque préalablement arrangée		: Vue
	: Zone du chargement à l'arrière du conducteur		
	: Zone du chargement à l'arrière du passager		

1 

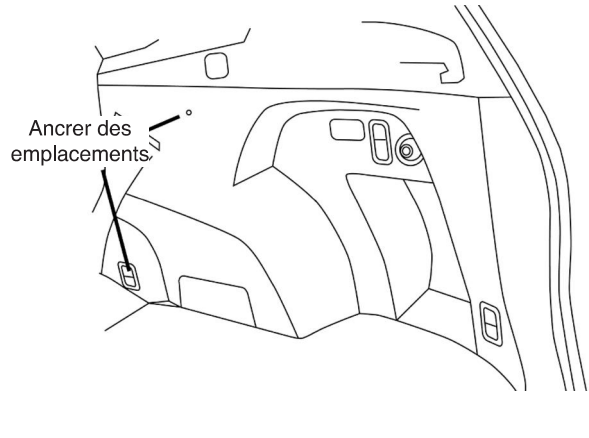

2 

 (Foret 1/4 pouces)

6 mm
(1/4 pouces)

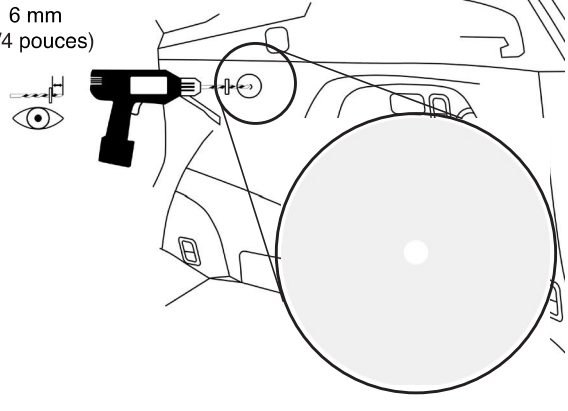

Note: Rechercher une zone d'alvéole sans texture.

3 

 (Foret 1/2 pouces) 13mm

6 mm
(1/4 pouces)

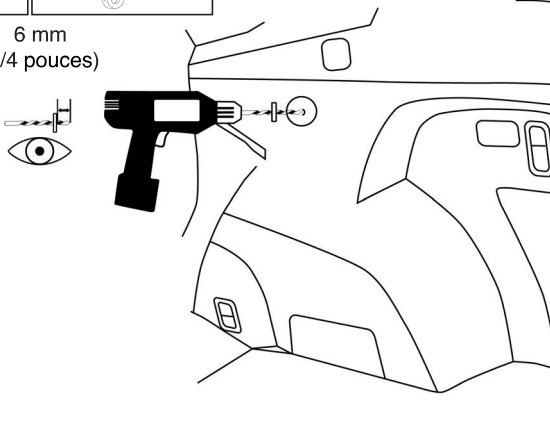

4 

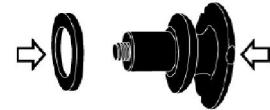

Note: l'entretoise doit être connectée à l'assemblage de champignon avant de l'installer dans le panneau.

4b



4c

Note: Serrez à la main la cheville du champignon dans le panneau jusqu'à ce qu'elle soit assurée.



5 

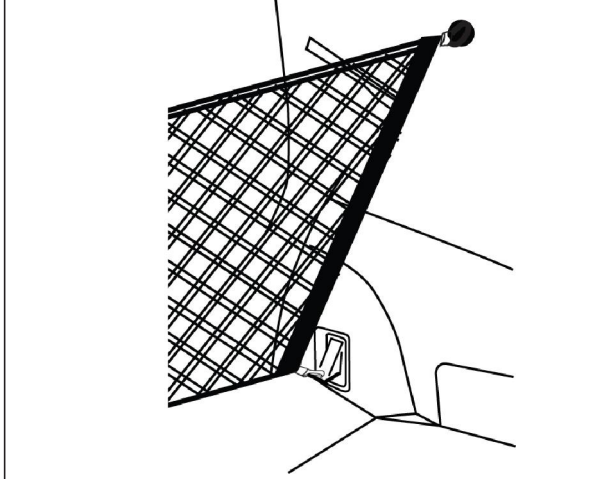

Note: l'installation est identique pour la partie opposée du véhicule.

6 

