

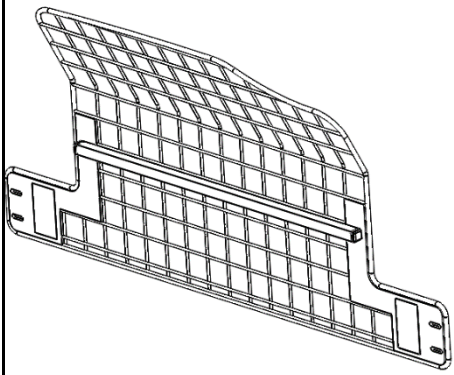

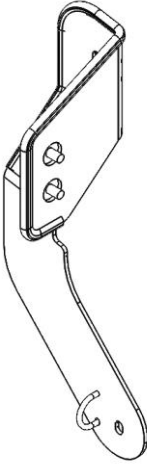

INSTALLATION INSTRUCTIONS

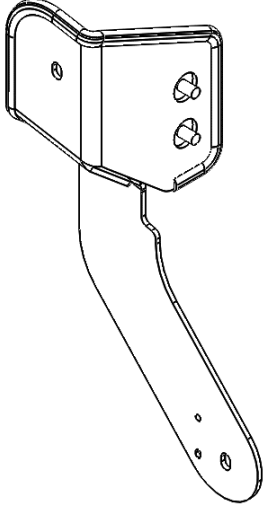

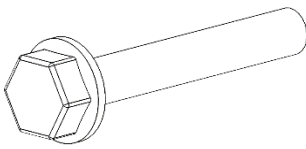
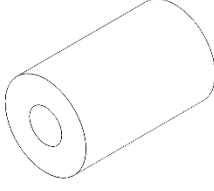
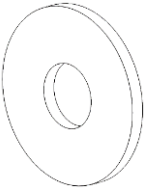
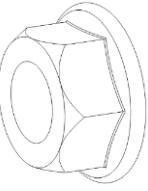
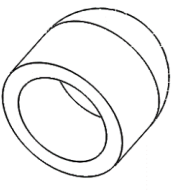
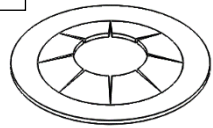







DESCRIPTION: Outback Cargo Separator

A	Mesh	B	Driver Side Bracket	C	Passenger Side Bracket
					
1X		1X		1X	

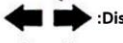
D	Bolt	E	Spacer	F	Large Flat Washer	G	Flange Nut
							
4X		4X		8X		4X	

H	Thread Cap	I	PAL Nut	J	Zip-lock Storage Bag	TOOLS REQUIRED	
						 Trim removal tool  M10 Hex Socket with Ratcheting Wrench  M10 Hex Socket with Torque Wrench	
4X		4X		1X			

Meaning of Characters:

 :Remove	 :Tightening Torque
 :Install	 :Loosen
 :Disconnect	 :Discard
 :Connect	 :Re-use
 :Push	
 :Location of Clips or Screws	

This product has been designed to allow for proper function of various vehicle safety components. Spacing near the side windows on both sides of the cargo separator are included in the design to allow for proper side curtain air bag clearances in the event of air bag deployment. Additionally, installation of this product will restrict the rear seats from fully reclining.

NOTE: This cargo separator is not suitable for containment of a pet. The cargo separator is designed to prevent average cargo larger than 10" x 10" stored in the cargo area from entering into the passenger compartment area. Items smaller than 10" x 10" may be able to pass through the openings on the side of the cargo separator that are required to provide clearance for the side curtain air bag.

1 If the center second row seat belt is installed, unlatch the seat belt and retract it to the ceiling mount.

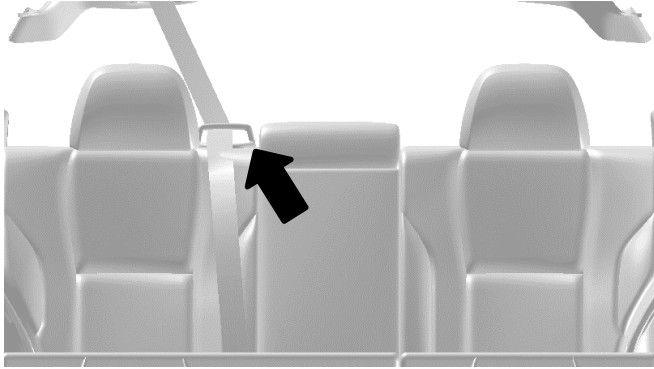

2 Fold the second row of seats down to allow for easier cargo area access during installation of the cargo separator.



3 Open the cover to the cargo hook assembly. Remove the bolt using a 10mm socket and then remove the complete cargo hook assembly. Repeat on opposite side. Store both cargo hook assemblies in the supplied Zip-lock storage bag. (J)

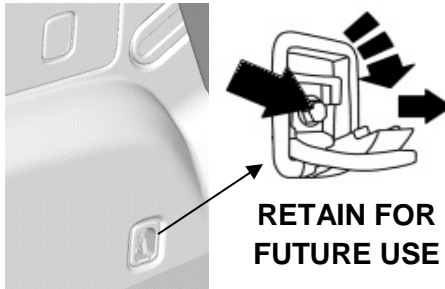

4 Remove the cover on the upper mounting location with trim removal tool. Repeat for opposite side. Store both trim covers in the supplied Zip-lock storage bag (J) and then place bag in glove box for future use.

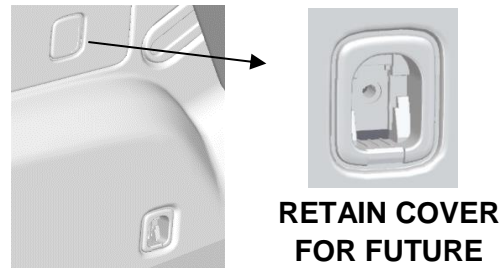

5 Place Bolt (D), Large Flat Washer (F), through hole of bracket. Place Spacer (E) on the bolt that is going through the bracket.

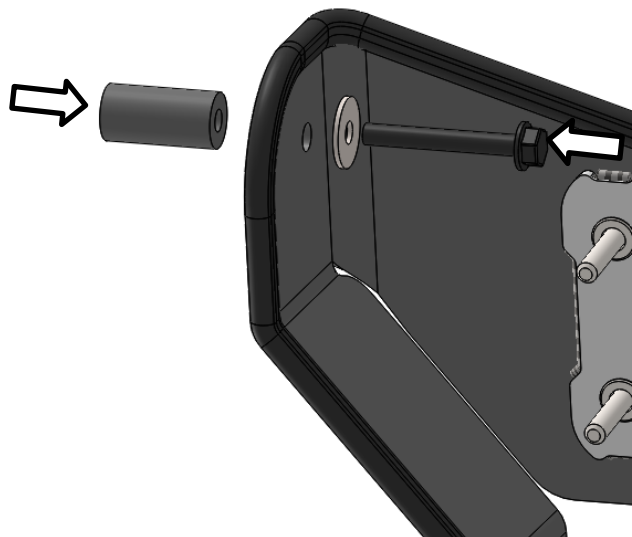

6 Take the PAL Nut (I) and place it over the bolt sticking through the bracket with the spacer. Push evenly on 2 sides of the PAL Nut until it is engaged with the Spacer. Repeat steps 5 and 6 for the 3 remaining holes in the brackets.

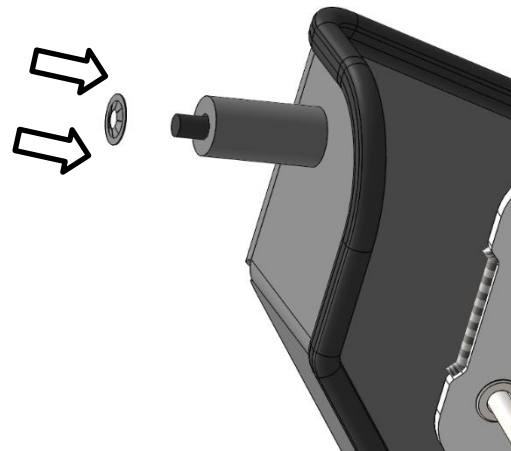

7 Install bracket (B) on the driver's side where the 2 mounting locations were. Hand-Tighten the top bolt first, then use a 10mm socket to torque both bolts to 8NM (70in-lbs).

T = 70.8±5 IN-LBF (8.0±0.56 N-M)

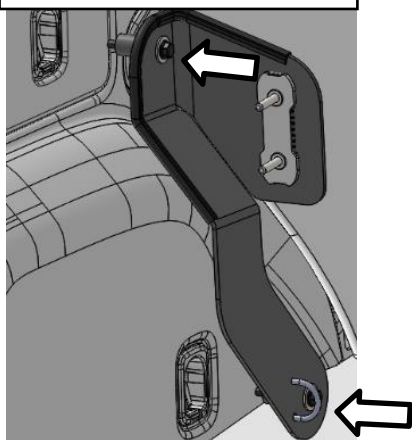

8 Install bracket (C) on the passenger side where the 2 mounting locations were. Hand-Tighten the top bolt first, then use a 10mm socket to torque both bolts to 8NM (70in-lbs).

T = 70.8±5 IN-LBF (8.0±0.56 N-M)

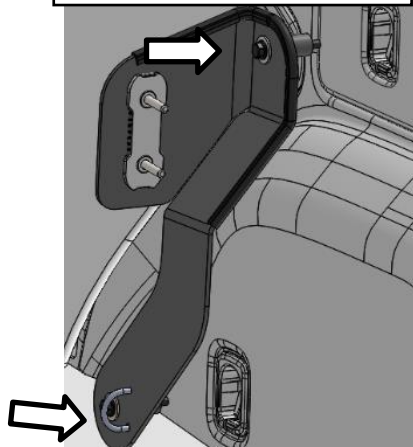

9 Install mesh (A) on the bracket studs (B, C).

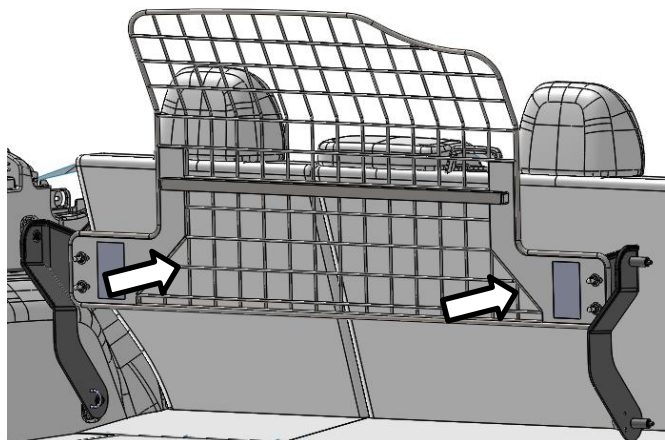

10 Install flange nut (G) and large flat washer (F) to the 2 studs on the left bracket. Hand tighten.

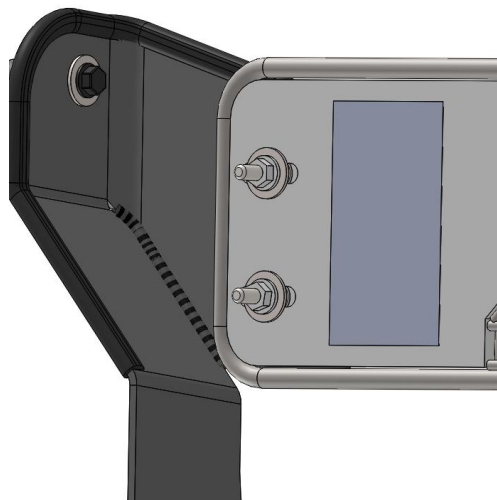

11 Install flange nut (G) and large flat washer (F) to the 2 studs on the right bracket. Hand tighten.

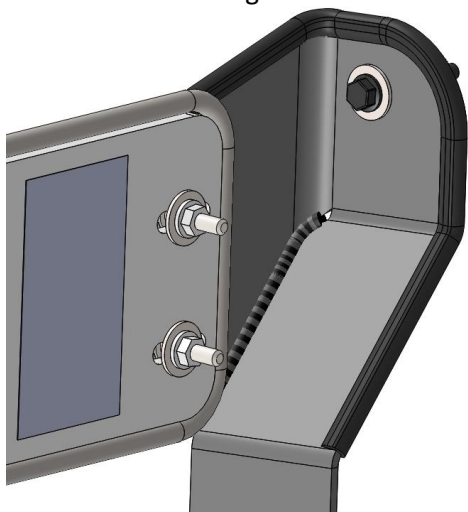

12 Tighten all four flange nuts (I) to T = 70.8±5 IN-LBF (8.0±0.56 N-M) using a 10mm socket with torque wrench. Torque in order shown.

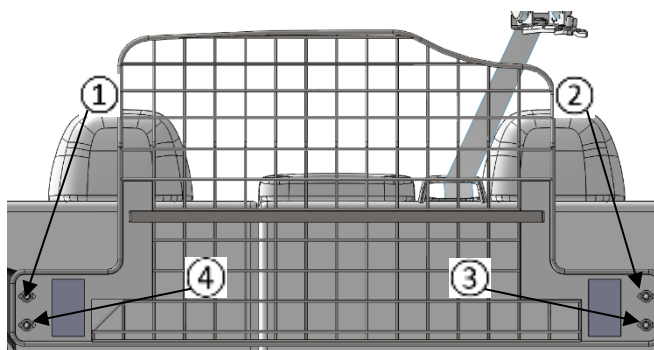

T = 70.8±5 IN-LBF (8.0±0.56 N-M)



INSTALLATION INSTRUCTIONS

- 13** Install the four cap plugs (H) onto the ends of the 4 studs sticking out towards the cargo area.

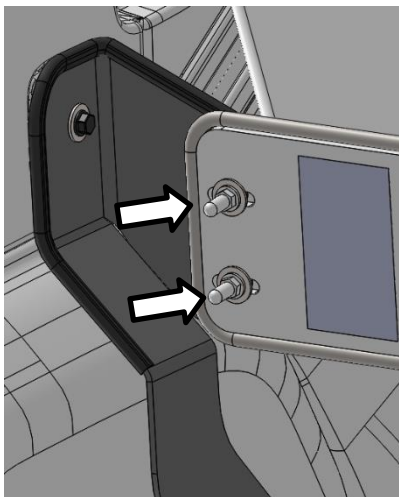

- 14** Pull the second row seat belt back down in front of the cargo separator and engage it with the latch in the second row.

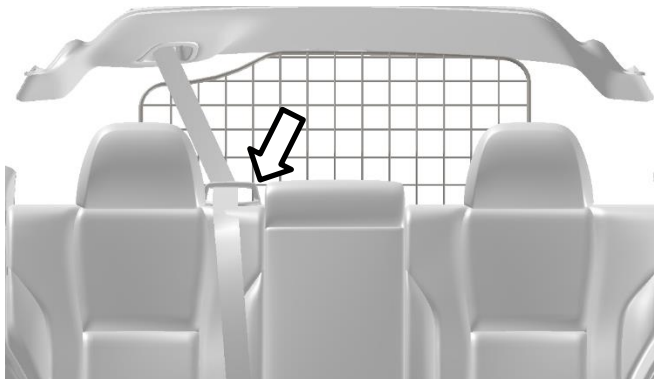

VERSION
01

DATE
04/16/19

SUBARU OF AMERICA



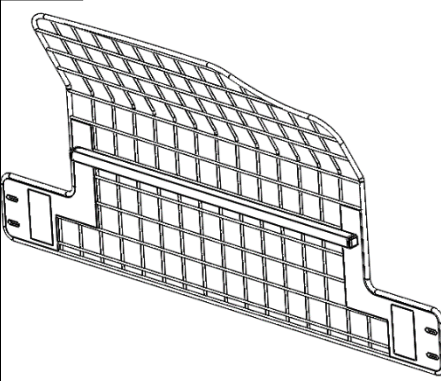
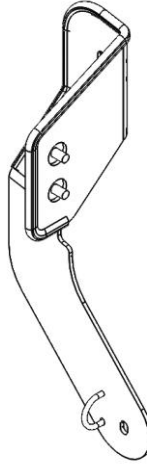
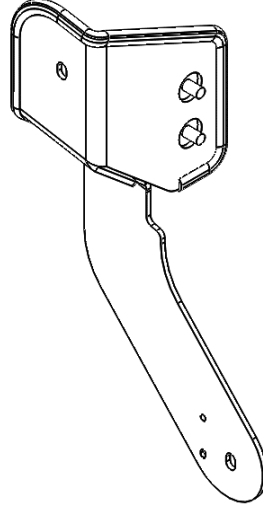

PAGE
4/8

INSTRUCTIONS D'INSTALLATION

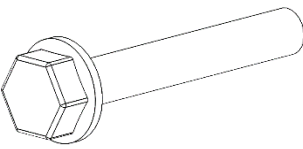
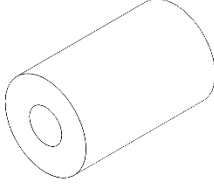
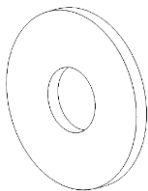
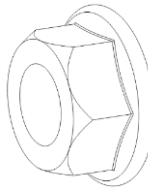

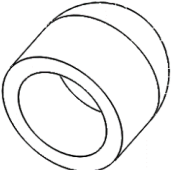
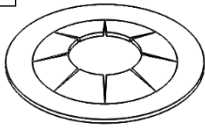







DESCRIPTION : Séparateur de fret dans l'Outback

<p>A Treillis</p>  <p>1X</p>	<p>B Support côté conducteur</p>  <p>1X</p>	<p>C Support côté passager</p>  <p>1X</p>
--	---	---

<p>D Boulons</p>  <p>4X</p>	<p>E Entretoise</p>  <p>4X</p>	<p>F Grande rondelle plate</p>  <p>8X</p>	<p>G Écrou à embase</p>  <p>4X</p>
--	---	---	---

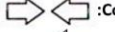
<p>H Bouchon fileté</p>  <p>4X</p>	<p>I Écrou-capuchon</p>  <p>4X</p>	<p>J Le sac de rangement à fermeture en plastique</p>  <p>1X</p>	<p>OUTILS REQUIS</p>  <p>Six pans creux M10 avec Clé à cliquet</p>  <p>Outil de finition Douille hexagonale M10 avec clé dynamométrique</p>
--	--	---	--

Meaning of Characters:

 :Remove	 :Tightening Torque
 :Install	 :Loosen
 :Disconnect	 :Discard
 :Connect	 :Re-use
 :Push	
 :Location of Clips or Screws	

Ce produit a été conçu pour permettre le fonctionnement adéquat de divers composants de sécurité du véhicule. On a prévu de l'espace près des glaces latérales des deux côtés du séparateur pour laisser suffisamment de dégagement aux rideaux gonflables latéraux advenant leur déploiement. En outre, l'installation de ce produit empêche les sièges arrière de s'incliner complètement.

REMARQUE : Ce séparateur d'espace utilitaire n'est pas adapté pour le confinement d'un animal domestique. Le séparateur d'espace utilitaire est conçu pour empêcher la cargaison moyenne de plus de 10 po x 10 po rangée dans l'espace utilitaire de pénétrer dans l'habitacle. Les articles plus petits que 10 po x 10 po pourraient passer à travers les ouvertures sur le côté du séparateur d'espace utilitaire, qui sont prévues pour laisser suffisamment de dégagement aux rideaux gonflables latéraux advenant leur déploiement.

1 Si la ceinture de sécurité du siège central de deuxième rangée est installée, détacher la ceinture de sécurité et la rétracter dans la support de montage au plafond.

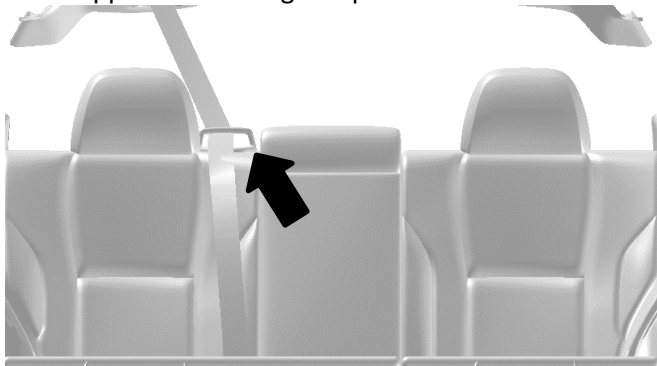

2 Rabattre les sièges de deuxième rangée pour faciliter l'accès à l'espace utilitaire pendant l'installation du séparateur d'espace utilitaire.



3 Ouvrir le couvercle du crochet d'arrimage. Retirer le boulon à l'aide d'une douille de 10 mm, puis le crochet d'arrimage en entier. Faire de même de l'autre côté. Ranger les deux crochets d'arrimage dans le sac de rangement à fermeture fourni. (J)

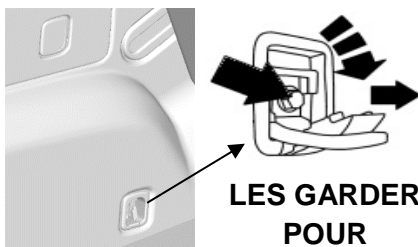

4 Retirer le couvercle du support supérieur avec l'outil de retrait de la garniture. Faire de même de l'autre côté. Ranger les deux couvercles de garniture dans le sac de rangement à fermeture fourni (J), puis placer le sac dans la boîte à gants pour une utilisation ultérieure.

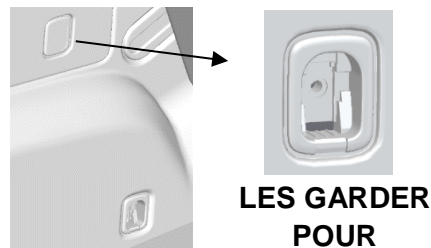

5 Placer le boulon (D), la grande rondelle plate (F), à travers le trou du support. Placer l'entretoise (E) sur le boulon traversant le support.

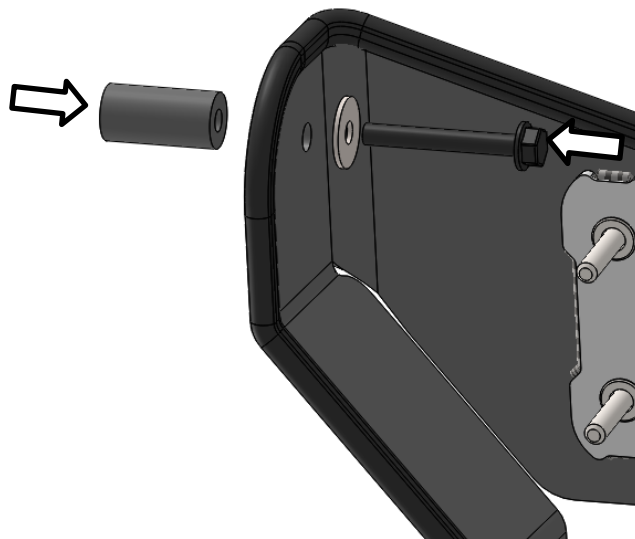

6 Prenez l'écrou PAL (I) et placez-le sur le boulon qui dépasse du support avec l'entretoise. Poussez uniformément sur les deux côtés de l'écrou PAL jusqu'à ce qu'il soit engagé avec l'entretoise. Répétez les étapes 5 et 6 pour les 3 trous restants dans les supports.

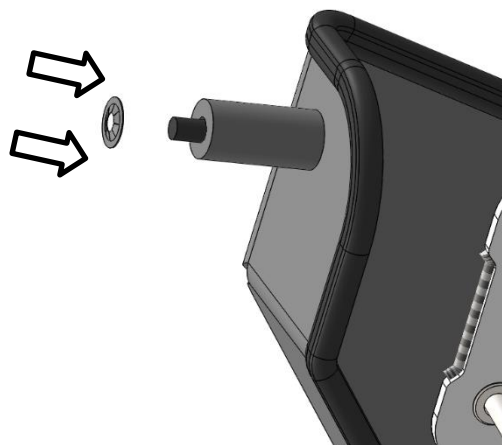

7 Poser le support (B) du côté conducteur à l'endroit où se trouvaient les 2 emplacements de montage. Serrer d'abord le boulon supérieur à la main, puis utiliser une douille de 10 mm pour serrer les deux boulons à 8 Nm (70 po-lb).

C = 8 N.m ± 0,56 N.m (70,8 lb-po ± 5,0 lb-po)

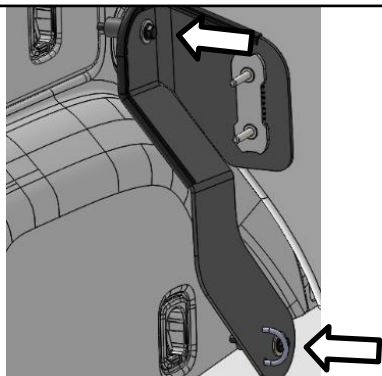

8 Poser le support (C) du côté passager à l'endroit où se trouvaient les 2 emplacements de montage. Serrer d'abord le boulon supérieur à la main, puis utiliser une douille de 10 mm pour serrer les deux boulons à 8 Nm (70 po-lb).

C = 8 N.m ± 0,56 N.m (70,8 lb-po ± 5,0 lb-po)

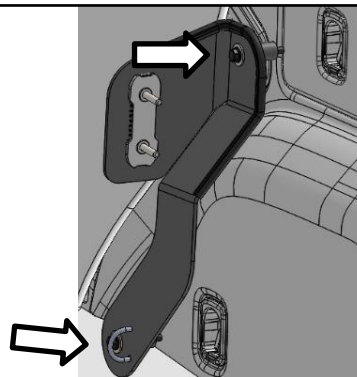

9 Poser le filet (A) sur les goujons de support (B, C).

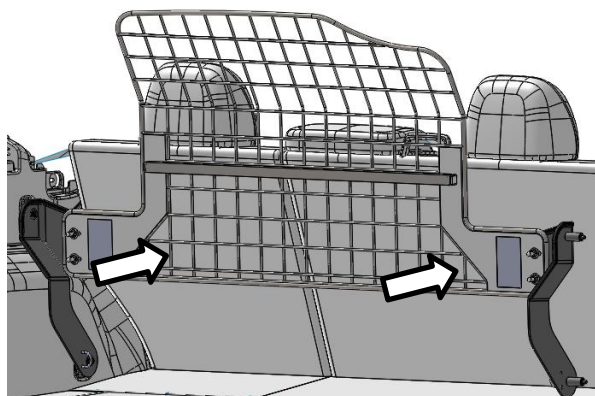

10 Poser l'écrou à bride (G) et la grande rondelle plate (F) sur les 2 goujons du support gauche. Serrer à la main.

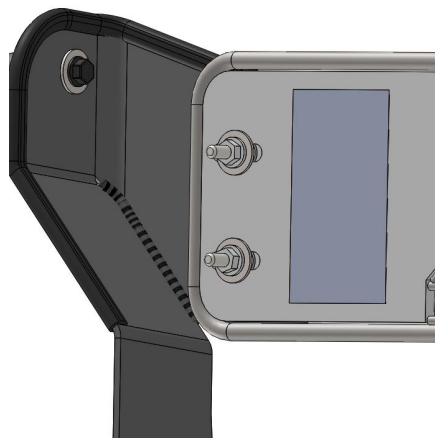

11 Poser l'écrou à bride (G) et la grande rondelle plate (F) sur les 2 goujons du support droit. Serrer à la main.

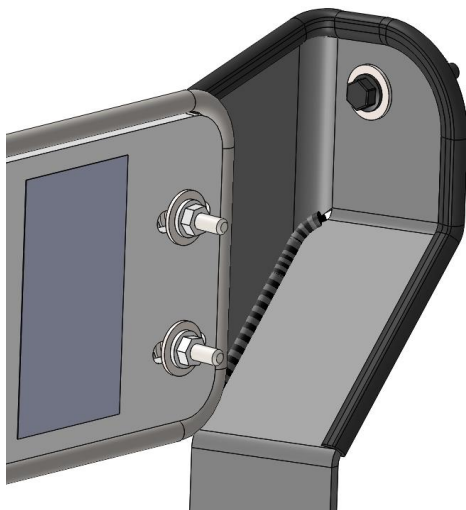

12 Serrer les quatre écrous à embase (I) au couple de 8 N.m ± 0,56 N.m (70,8 lb-po ± 5,0 lb-po) à l'aide d'une douille de 10 mm et une clé dynamométrique. Serrer dans l'ordre indiqué.

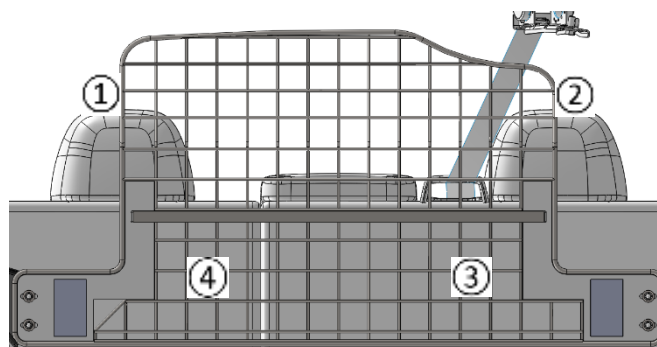

C = 8 N.m ± 0,56 N.m (70,8 lb-po ± 5,0 lb-po)

- 13** Installer les quatre capuchons (H) sur les extrémités des goujons dépassant dans l'espace utilitaire.

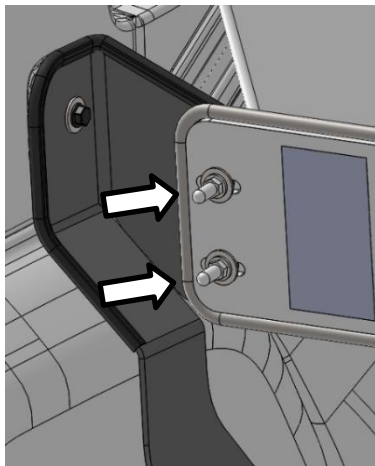

- 14** Tirer la ceinture de sécurité de deuxième rangée vers le bas à l'avant du séparateur d'espace utilitaire et enclencher le verrou dans la deuxième rangée.

