



Exhaust finisher

Instruction Manual

Applicable model : WRX 2022MY ~

This manual describes how to install and handle the Exhaust finisher. Read this manual carefully before work and make sure to install it correctly.

Please

1. Be sure to read this manual before installation to ensure correct installation. Never modify or install this product.
2. The caution marks  shown in this installation manual are important installation precautions. Please adhere to it.
3. Please note that we may not be liable for any problems caused by not observing the items described.

Precautions

1. Before installation, turn off the ignition switch and apply the parking brake securely. Please adhere to it. After running the engine, the muffler will become hot, so allow it to cool down before installing.
2. If the temperature is 15 ° C or less, warm the double-sided tape attachment part of this product and the vehicle attachment part to about 30 ° C to 50 ° C with a dryer. Avoid using industrial dryers.
3. Double-sided tape will not stick unless you press it. Also, if you re-paste it, the adhesive ability will be extremely reduced, so position it so that it will not be re-pasted before adhering.
4. Double-sided tape gradually increases its adhesive strength after being attached. Please avoid car wash within 24 hours after installation. If you need to wash or wax the car on the day of installation, leave it for at least 1 hour and then cover it with tape to prevent water from getting into the double-sided tape sticking part. Also, be careful not to apply extra force to the exhaust finisher. (Avoid high-pressure car wash and automatic car wash on the day of installation.)
5. Do not remove the packing attached to the outer circumference as it is attached to ensure safety in appearance and during installation work and use.

Revised content

Δ	Contents	date of issue
Δ0	Create New	2021.8.19
Δ1	Old product number added	2022.3.24

Exhaust finisher

Genuine part number : E 7 7 1 0 V C 5 0 0 / 5 0 1

Applicable model : WRX 2022MY~

1 Specification

(1) Material

Exhaust finisher body : stainless

(2) Component part

	Parts name	quantity		Parts name	quantity
①	Exhaust finisher	R/L 1each	⑦	M3nut	6
②	M5×16bolt (Dummy bolt)	4			
③	M5 Nylon washer	4			
④	M5 Lock nut	4			
⑤	M3×8bolt	6			
⑥	M3 Nylon washer	6			

2 Tools used

- ϕ 4.0 Drill
- Opposite side 5.5mm spanner
- Opposite side 3mm hex wrench
- Punch etc.
- Washing soap (Recommended Nonane)
- Dryer (used when the temperature is 15°C or less)
- ϕ 15 hole saw
- Opposite side 8 mm spanner
- Opposite side 1.5 mm hexagon wrench
- Clip removal
- Waste cloth

Installation completed drawing

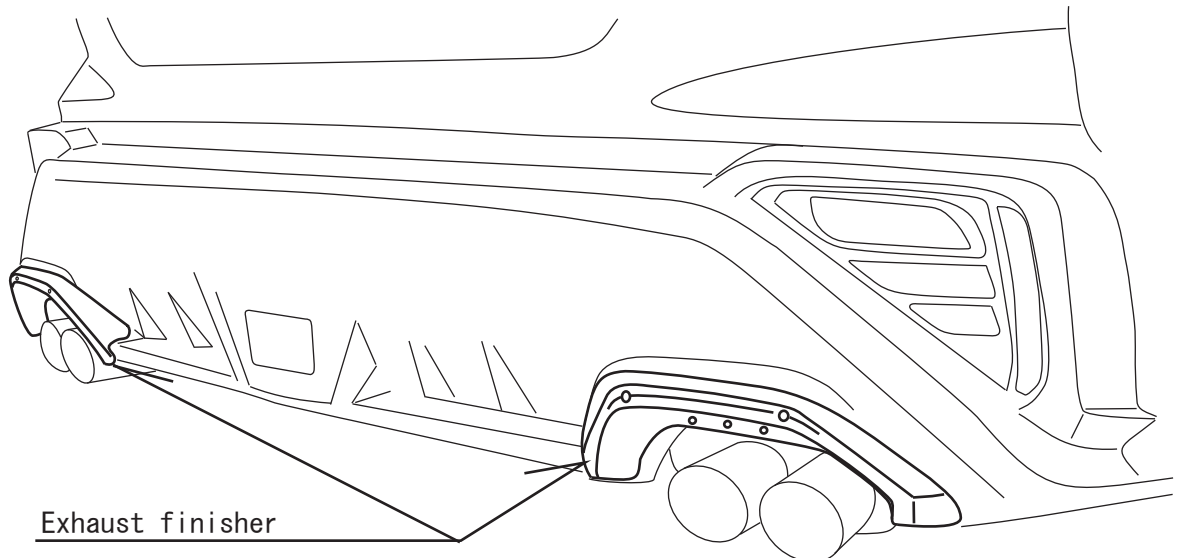

3 Installation procedure

The figure shows LH, but install RH in the same way.

- (1) Remove the clips (2 places) that secure the cover muffler.
Pull the cover muffler backwards to remove it from the bumper.

(Fig. 1)

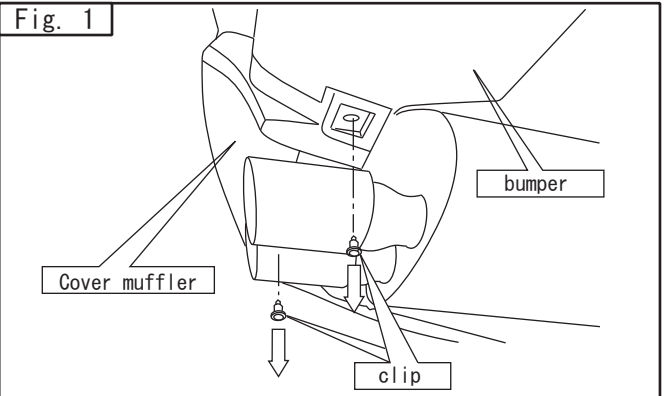

- (2) Cover the cover muffler with the exhaust finisher and mark the center of the dummy bolt escape hole and M3 bolt mounting hole with a punch etc.

(Fig. 2)



Note

Make sure that the outer trim lines on the top of the cover muffler and exhaust finisher are aligned.

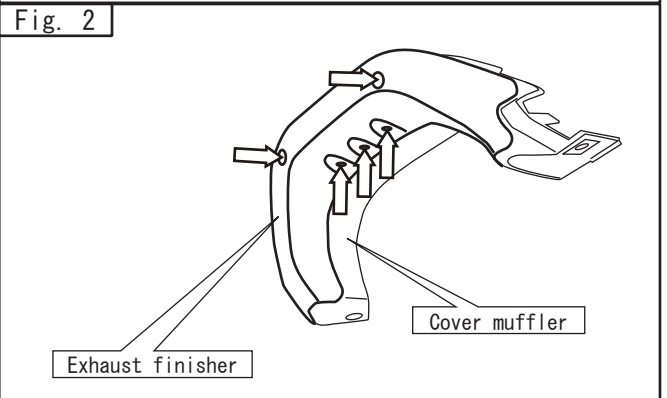

- (3) Remove the exhaust finisher and make a hole with a $\phi 4$ drill at the mark of the M3 bolt mounting hole (3 places).

(Fig. 3)



Note

When drilling, be careful that the drill is perpendicular to the drilling surface.

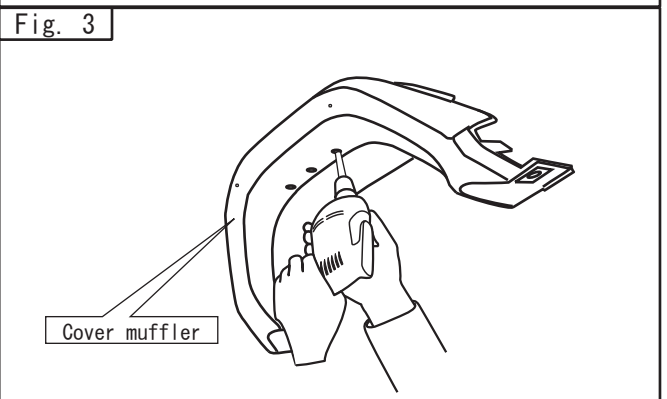

- (4) Make a hole with a $\phi 15$ hole saw at the mark of the escape hole (2 places) of the decorative bolt.

(Fig. 4)



Note

When drilling, be careful that the drill is perpendicular to the drilling surface.

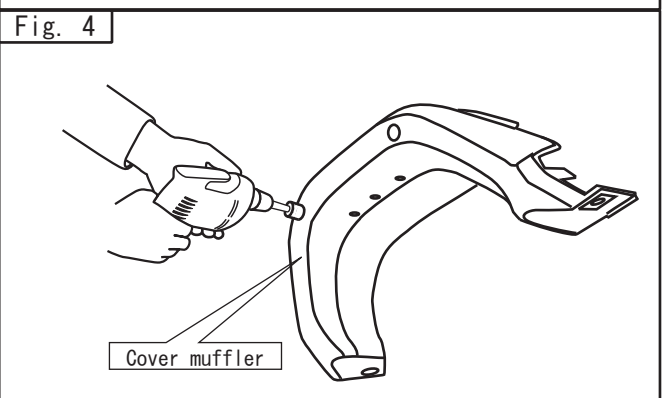

- (5) Clean the surface of the cover muffler with a rag soaked in detergent and let it dry.

(Fig. 5)

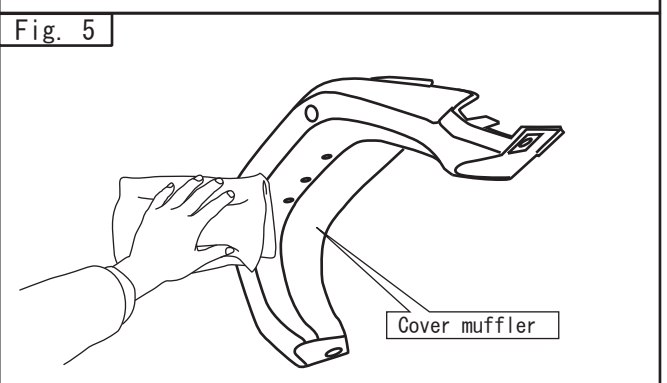

(6) Pass the M5 bolt (dummy bolt) through the dummy bolt mounting hole of the exhaust finisher, and tighten the M5 nylon washer and M5 nut on the back side with a tightening torque of 2 ± 0.1 Nm.

(Fig. 6)

(7) Peel off half of the double-sided tape release paper (3 places).

(Fig. 7)

(8) Cover the cover muffler with the exhaust finisher.

(Fig. 8)

(9) Insert the M3 bolt and tighten the nylon washer for M3 and the M3 nut on the back side with a tightening torque of 0.7 ± 0.1 Nm.

(Fig. 9)

⚠ Note

Make sure that the outer trim lines on the top of the cover muffler and exhaust finisher are aligned.
If they are not aligned, fine-tune the assembly position.

(10) Peel off all the double-sided tape release papers (3 places).

(Fig. 10)

(11) In the reverse procedure when removing, fit the cover muffler into the bumper, fix it with a clip, and the work is completed.

⚠ Inspection procedure

- There is no difference between the left and right sides of the car body.
- Check the tightening condition of the bolts and make sure there is no rattling.

