



STI Rear Side Under Spoiler

Installation Manual

Genuine part number : E5610FN000/010

Applicable model : I M P R E Z A (G U) , T Y P E A ~

- This manual describes how to install and handle the STI Rear Side Under Spoiler.
- Read this manual carefully before work and make sure to install it correctly.

Precautions

- Install the STI Rear Side Under Spoiler by reading the Installation Manual carefully.
- Handle the STI Rear Side Under Spoiler with care and do not let it fall.
- Do not install or use this product in any way other than described in this manual.
- We do not assume any responsibility for any trouble arising from failure to comply with the instructions in this manual.
- Double-sided tape is used to attach the STI Rear Side Under Spoiler.
Attach it with care as once it is attached, it is extremely difficult to remove.

Installation Completion Illustration

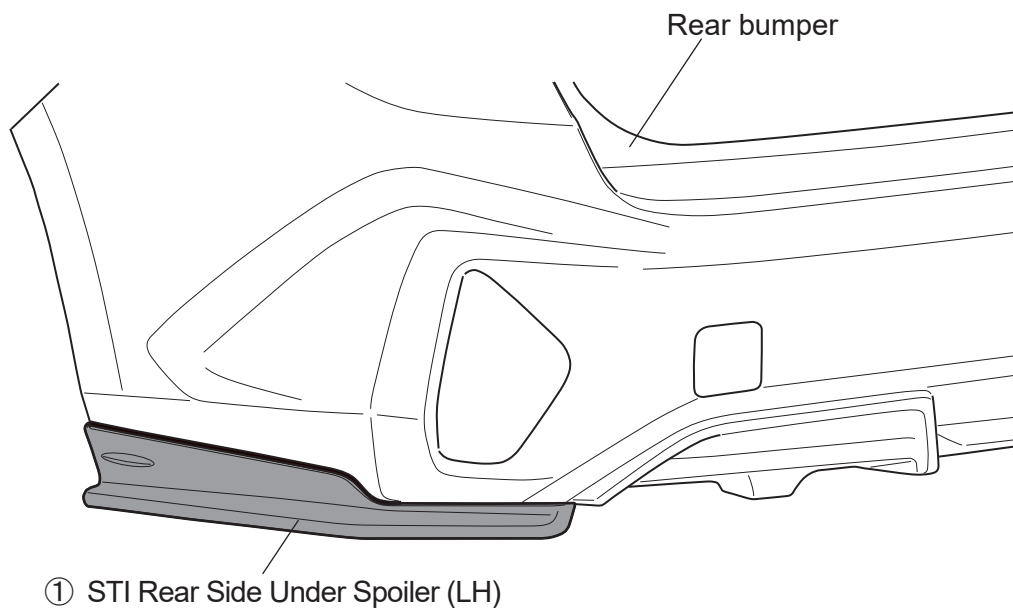

Components

- Make sure to check the components below before installation.

No.	Part Name	Qty
①	STI Rear Side Under Spoiler	RH:1 /LH:1
②	Clip(Large)	6
③	Clip(Medium)	2
④	Clip(Small)	2
⑤	Washer(t4.0)	4
⑥	Washer(t1.2)	2
⑦	Wellnut	2
⑧	Bolt	2

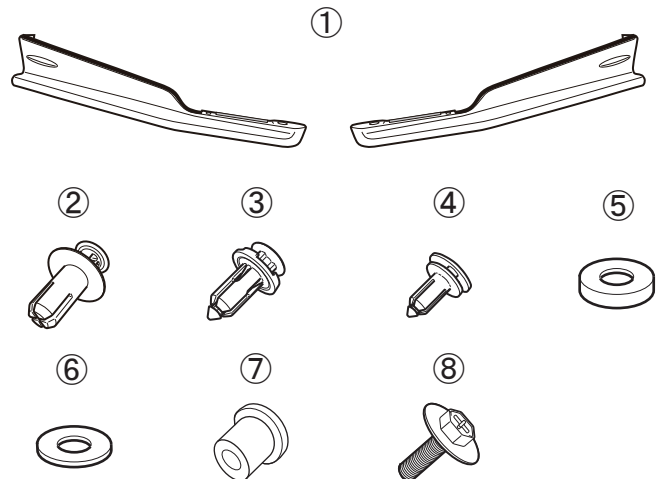

- E5610FN002/012 : STI Rear Side Under Spoiler RH ①RH × 1

E5610FN003/013 : STI Rear Side Under Spoiler LH ①LH × 1

E5610FN001 : Parts set ②×6 ③×2 ④×2 ⑤×4 ⑥×2 ⑦×2 ⑧×2

Tools

- Degreasing agent (recommended nonane)
- Dryer
- Masking tape
- Clip remover
- Gloves
- Protective eyewear
- Needle
- Torque wrench
- Clean cloth
- Needle nose pliers
- cloth adhesive tape
- Sandpaper
- Drill 3mm 5mm 7mm 9.5mm
- Phillips screwdriver
- Socket 8mm

Before Work

- When installing this product, park the car on a level ground and apply the parking brake.
- When installing this product, be sure not to damage the car body.
- Before installing this product, wipe off any dirt or oil film from the Rear bumper attachment surface with a soft waste cloth dampened in a neutral detergent. Then, let it dry completely before work.
- The adhesive strength is weakened significantly when the temperature is 15°C or low. In this case, use a dryer to warm the double-sided tape before attachment.
(Do not warm up excessively as doing so may result in deformation.)
- Be extremely careful not to let this product get wet by washing, etc. for 24 hours after attaching it. Dosing so may cause the product to come off.
- To protect yourself from burns, make sure to stop the engine and let it cool completely before work
- When jacking up the vehicle, be sure to keep the ground level and a hard place where the jack does not bite, and be sure to support it with a rigid rack before carrying out the work.

Installation procedure

1. Drill holes in the Rear Bumper

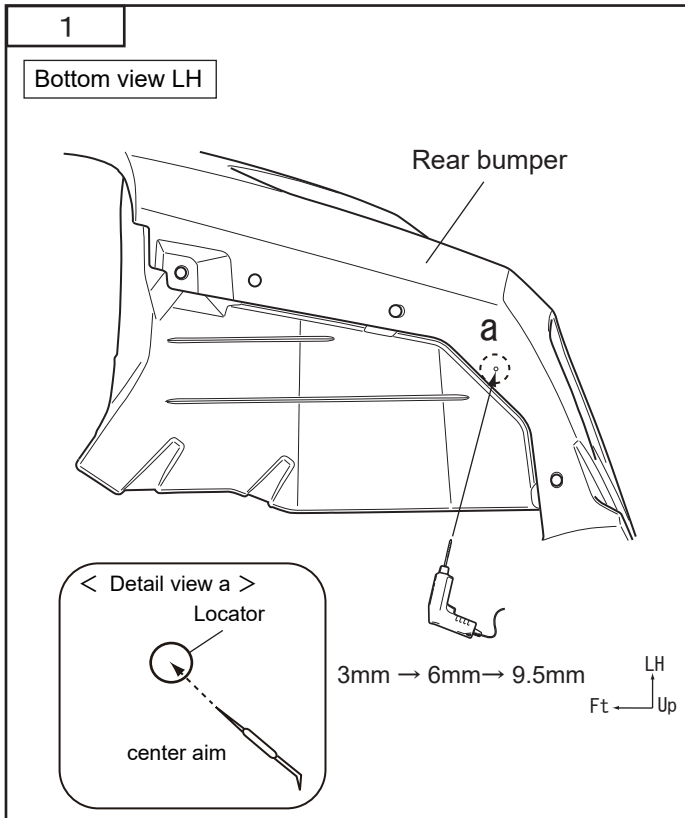

(The RH also performs the same work.)

- (1) As shown in Fig 1, Mark the center of the circle on the locator on the bottom of the Rear bumper with a marking needle or the like. After that, drill pilot holes in order of 3mm, 6mm, and finally drill a hole of 9.5mm.

(1 places each for LH and RH, 2 places in total)

! Advice

To prevent the drill from interfering with other parts when drilling, make a stopper with cloth adhesive tape, etc., at a point about 5 mm from the tip of the drill before working.

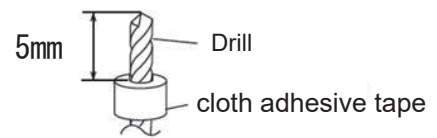

! Advice

After drilling, remove the burrs around the hole.

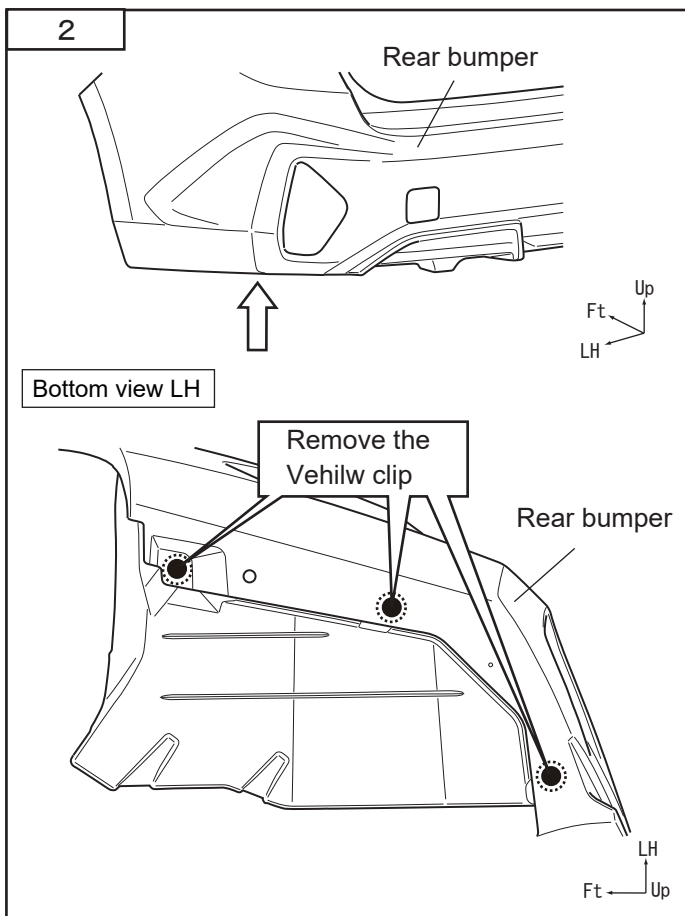

- (2) Remove the vehicle clips on the lower surface of the Rear bumper (three locations on one side) shown in Fig 2.

! Advice

- Do not reuse the removed vehicle clip.

Be sure to use the supplied clips.

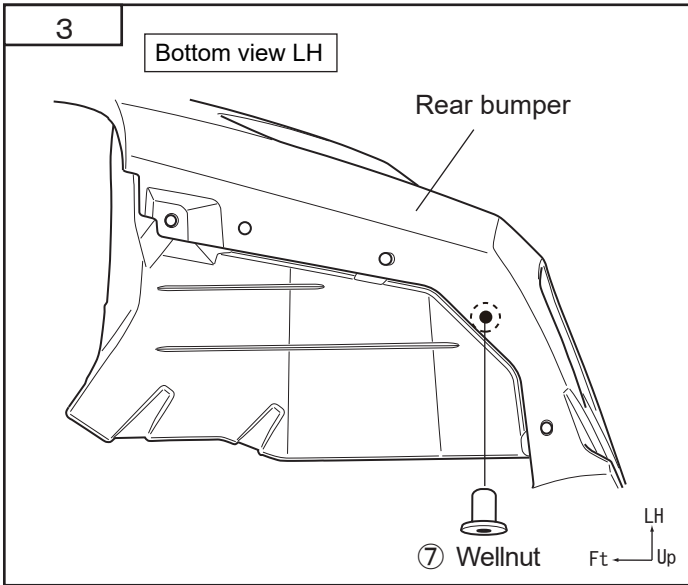

- (3) Insert the ⑦ Wellnut into the 9.5 mm hole.
 (1 place each for LH and RH, 2 places in total)

! Advice

If it is difficult to insert the well nut, insert it carefully without twisting it too much.

2. Cleaning/Degreasing

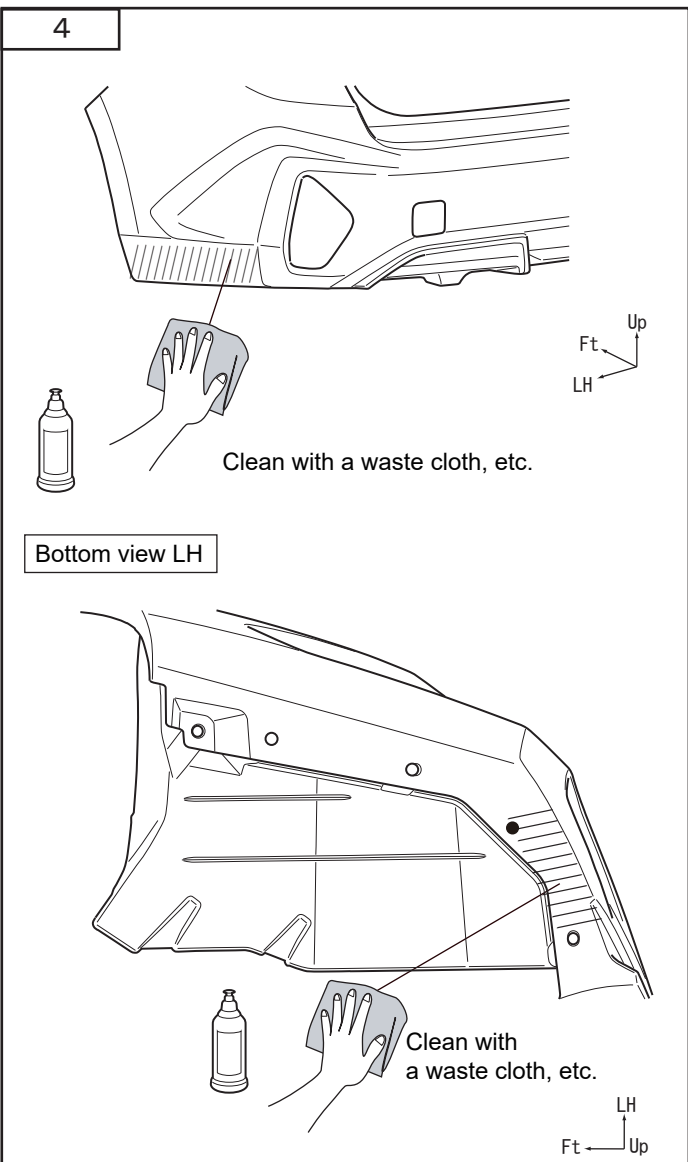

(The RH also performs the same work.)

- (1) Clean, degrease, and dry the shaded area of the Rear bumper with a degreasing agent.

! Advice

If rainwater is attached, wipe it dry with a dry cloth.

Insufficient wiping and drying can cause the product to come off.

3. Installation of STI Rear Side Under Spoiler

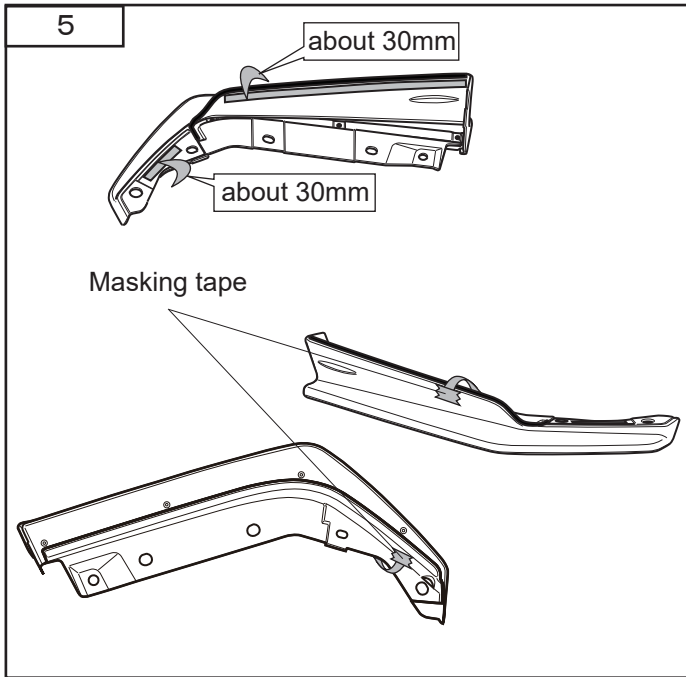

- (1) Peel off about 30mm of the release paper from the double-sided tape attached to the ① STI Rear Side Under Spoiler, fold it back, and then attach it to the back of the product with masking tape, etc., as shown in Fig 5.

⚠ Advice

Do not remove the release paper more than necessary.
The double-sided tape clings to the peripheral parts, which makes it difficult to position them.

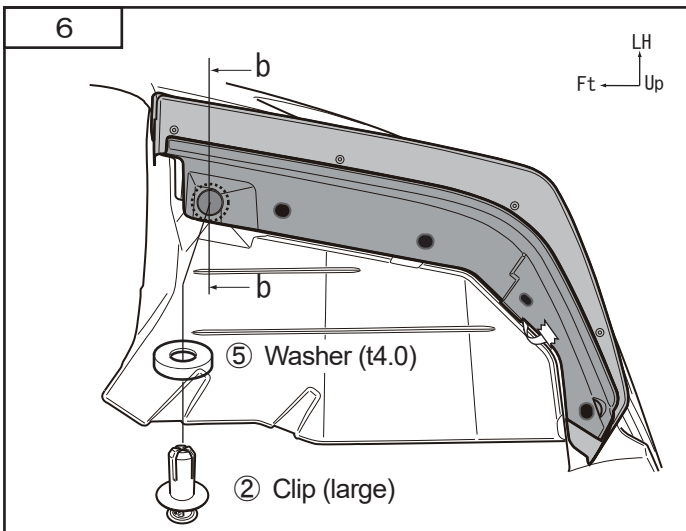

- (2) As shown in Fig 6, align the ① STI Rear Side Under Spoiler with the rear bumper, and fix the fastening hole on the front side of the vehicle with ⑤ Washer (t4.0) and ② Clip (Large).

(1 places each for LH and RH, 2 places in total)

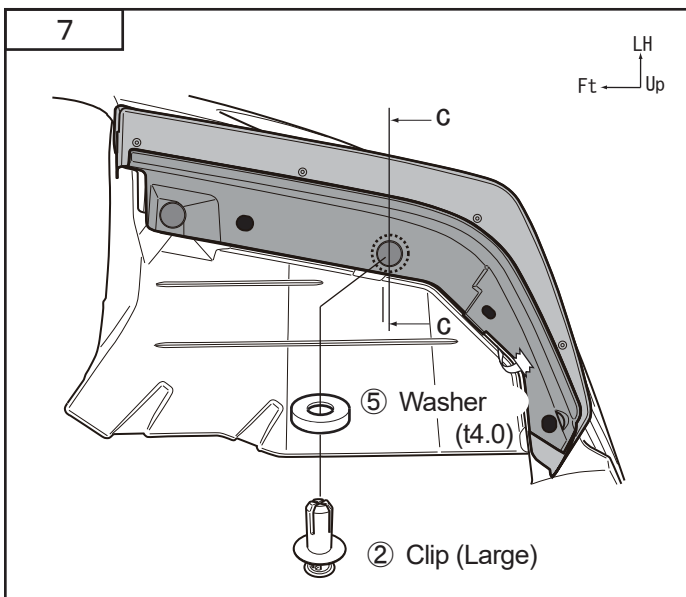
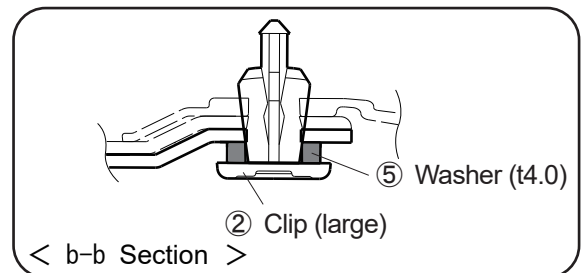

- (3) As shown in Fig 7, fix the fastening hole with ⑤ Washer (t4.0) and ② Clip (Large).

(1 places each for LH and RH, 2 places in total)

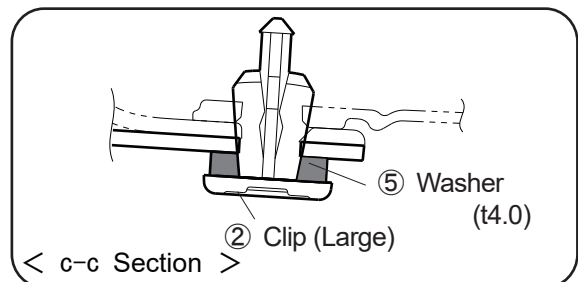

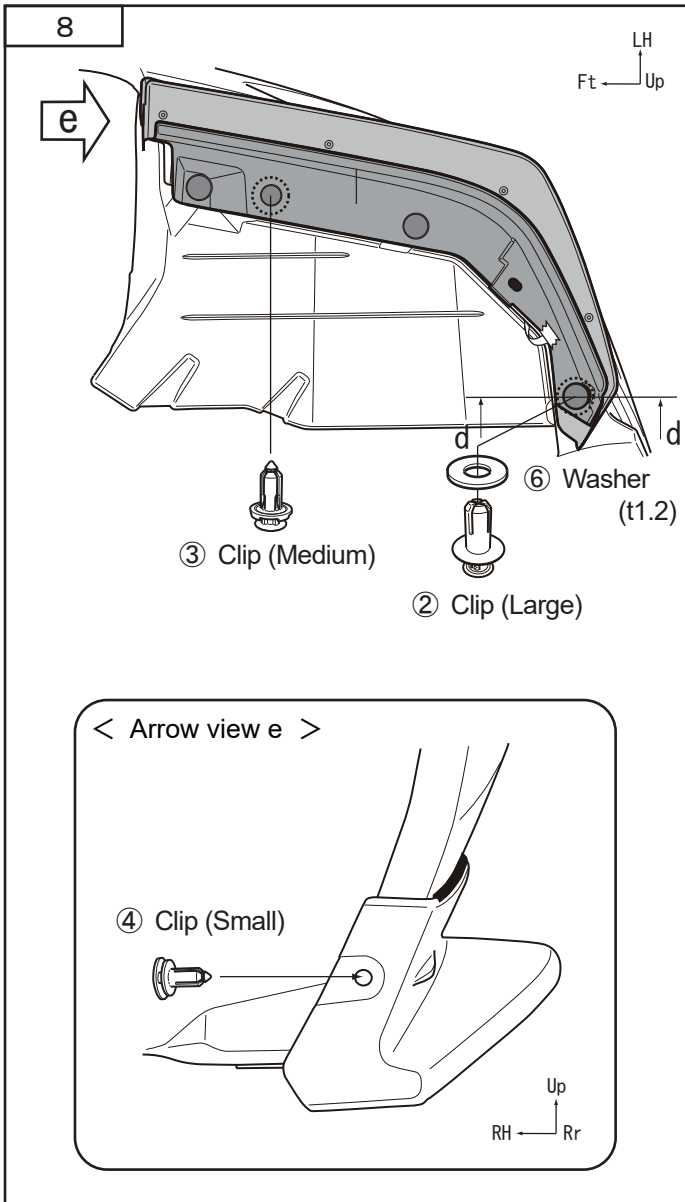

- (4) As shown in Fig. 8, secure the fastening hole on the front end of the vehicle with ③ Clip (Medium), and the fastening hole on the rear end of the vehicle with ⑥ Washer (t1.2) and ② Clip (Large). Secure the fastening hole on the wheel arch side with ④ Clip (Small).

(3 places each for LH and RH, 6 places in total)

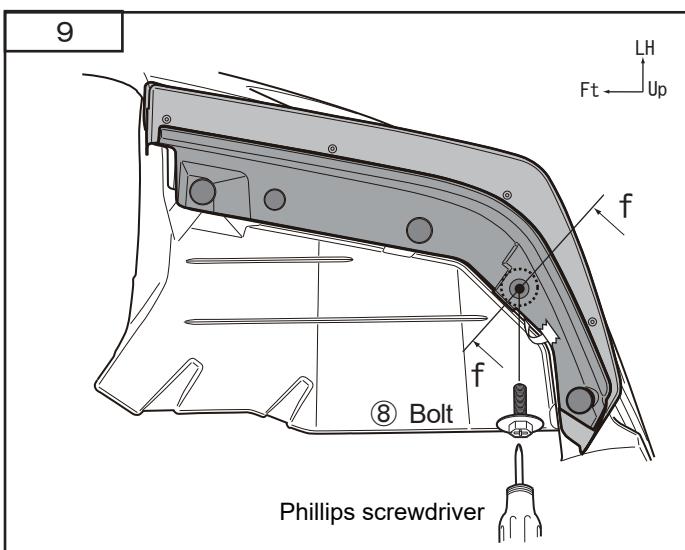
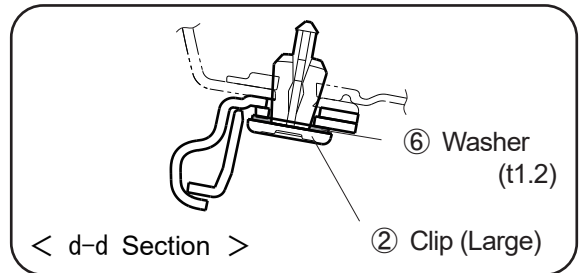

- (5) As shown in Fig 9, use a Phillips screwdriver to temporarily tighten the remaining fastening holes with ⑧ Bolt.

(1 places each for LH and RH, 2 places in total)

※Put your hand from the back of the bumper and tighten while holding down the bumper downward.

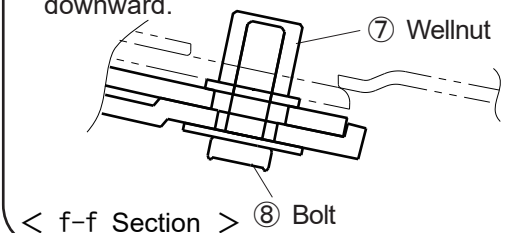

10

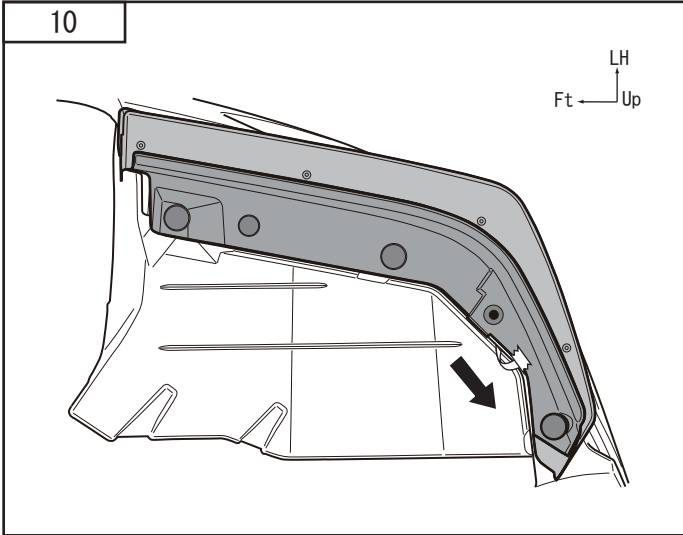

- (6) As shown in Fig 10, press the double-sided tape while slowly pulling out the release paper in the direction of the arrow so as not to tear it.

! Advice

If it is difficult to remove the release paper, slowly pull it out with needle-nose pliers.

- (7) Press the adhesive part of the double-sided tape with enough force to shake the car. (49N or more)

11

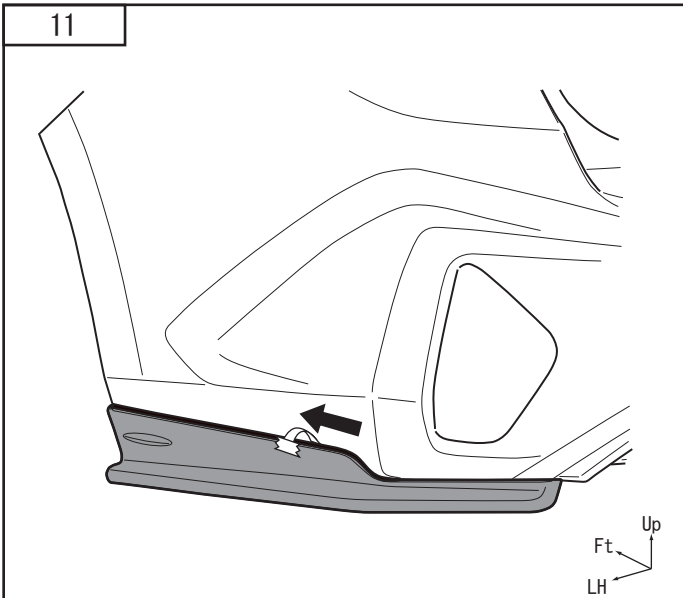

- (8) As shown in Fig 11, press the double-sided tape while slowly pulling out the release paper in the direction of the arrow so as not to tear it.

! Advice

If it is difficult to remove the release paper, slowly pull it out with needle-nose pliers.

Make sure that the molding does not turn over when pulling out the release paper.

- (9) Press the adhesive part of the double-sided tape with enough force to shake the car. (49N or more)

12

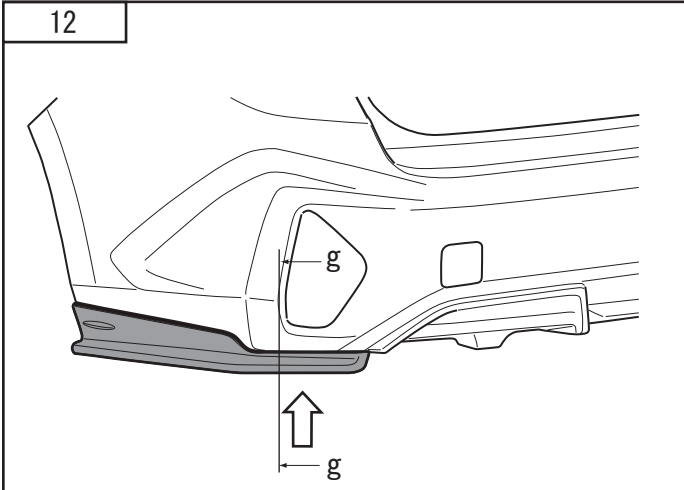

(10) Fully tighten the ⑧ Bolt on the bottom surface of the ① STI Rear Side Under Spoiler with a Phillips screwdriver.

(1 place each for LH and RH, 2 places in total)

⚠ Advice

Reference tightening torque 1.0N · m
(0.1kgf · m)

※Insert your hand from the back of the bumper and check that the top of the wellnut and the end of the bolt are aligned (flush).

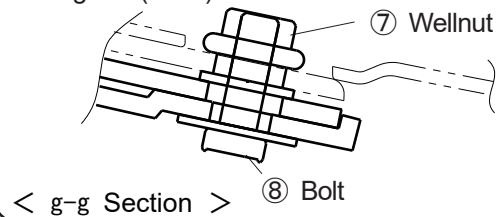

(11) Finally, check the float and inclination of the mounting part, and confirm that there are no missing clips or bolts, and that there are no omissions in tightening.

This is the end of the work.

To customers

- We do not accept warranty repairs such as scratches, discoloration of paint, and peeling that occur during use.
- The back side of this product is not painted. It may vary depending on the product.
- By installing this product, it is up to 15mm lower than the Rear bumper.
- Because it is easy to come into contact with curbs, ring clasps, steps, etc.
Be careful not to touch it while driving or parking.
If it comes in contact with it, it may be scratched, deformed, damaged or dropped, and the spoiler may be damaged accordingly.
- In the case of slight contact, you may not notice the contact, so be sure to perform a pre-operation inspection and check the area around the mounting part in particular.
- Also, running in snow or ruts may damage the spoiler, deform it, drop it off, or damage the vehicle.
Damage caused by these or equivalent external forces is not covered by the warranty.

Revised contents

△	Details of the work	Date
00	Newly created document	26 / Jan / 2023