



STI Rear Side Under Spoiler

Installation Manual

Genuine part number : E5610CC000

Applicable model : BRZ (ZD) , A Type~

- This manual describes how to install and handle the STI Rear Side Under Spoiler.
- Read this manual carefully before work and make sure to install it correctly.

⚠ Precautions

- Install the STI Rear Side Under Spoiler by reading the Installation Manual carefully.
- Handle the STI Rear Side Under Spoiler with care and do not let it fall.
- Do not install or use this product in any way other than described in this manual.
- We do not assume any responsibility for any trouble arising from failure to comply with the instructions in this manual.
- Double-sided tape is used to attach the STI Rear Side Under Spoiler. Attach it with care as once it is attached, it is extremely difficult to remove.

Installation Completion Illustration

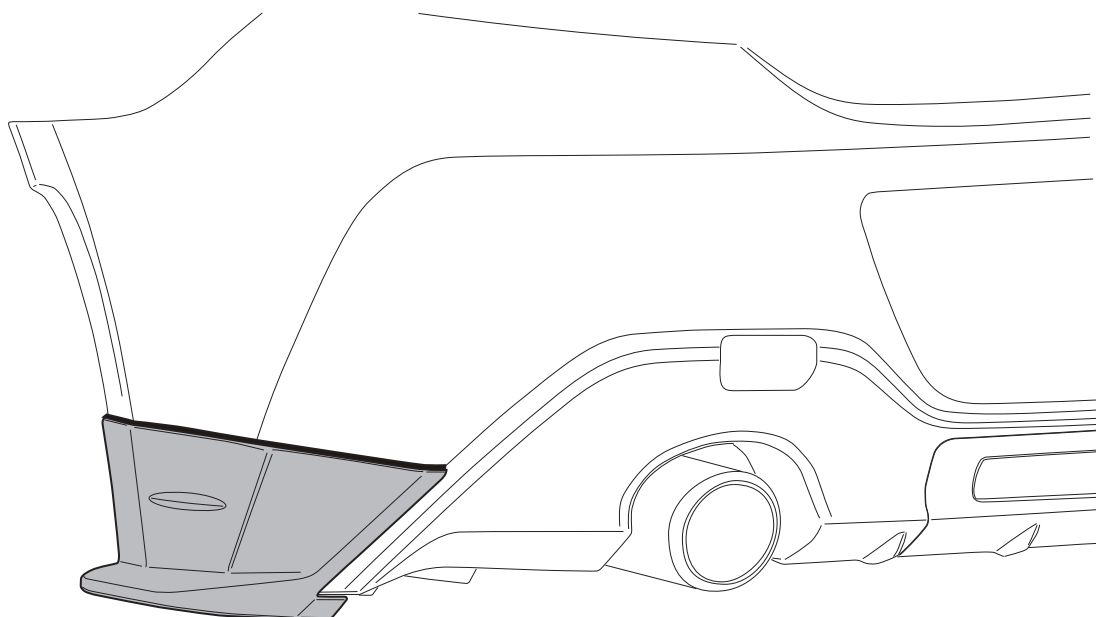

Components

- Make sure to check the components below before installation.

No.	Part Name	Qty
①	STI Rear Side Under Spoiler	RH:1 /LH:1
②	Clip(Large)	2
③	Clip(Medium)	2
④	Clip(Small)	2
⑤	Patten paper RH/LH	1

①

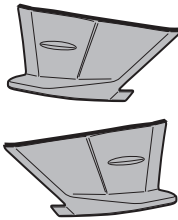

②



③



④



⑤

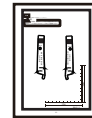

Tools

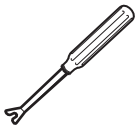

φ 3mm φ 6mm φ 7mm



Before Work

- When installing this product, park the car on a level ground and apply the parking brake.
- When installing this product, be sure not to damage the car body.
- Before installing this product, wipe off any dirt or oil film from the Rear bumper attachment surface with a soft waste cloth dampened in a neutral detergent. Then, let it dry completely before work.
- The adhesive strength is weakened significantly when the temperature is 15°C or lower. In this case, use a dryer to warm up the double-sided tape before attachment. (Do not warm up excessively as doing so may result in deformation.)
- Be extremely careful not to let this product get wet by washing, etc. for 24 hours after attaching it. Doing so may cause the product to come off.
- To protect yourself from burns, make sure to stop the engine and let it cool completely before work.
- When jacking up the vehicle, be sure to keep the ground level and a hard place where the jack does not bite, and be sure to support it with a rigid rack before carrying out the work.

1

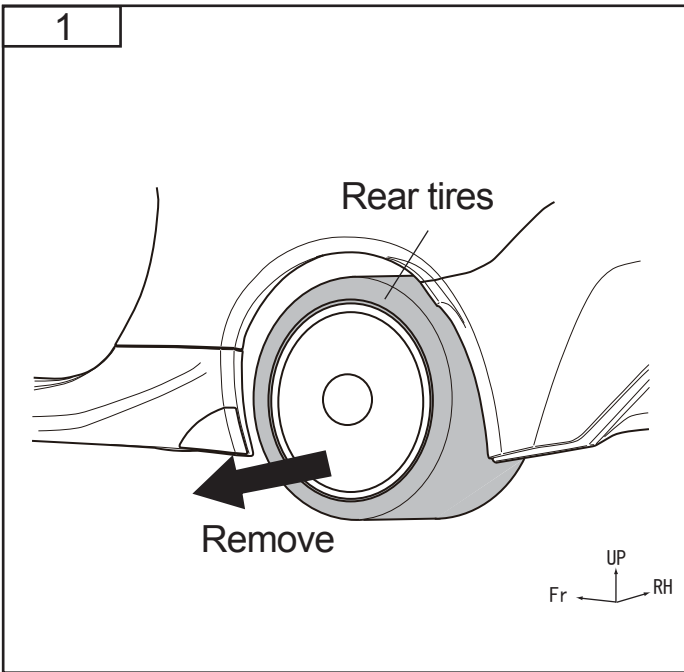

Remove the Rear tires

- 1.Refer to the service manual and remove the rear tires from the vehicle.
(1 places each for RH and LH, 2 places in total)

2

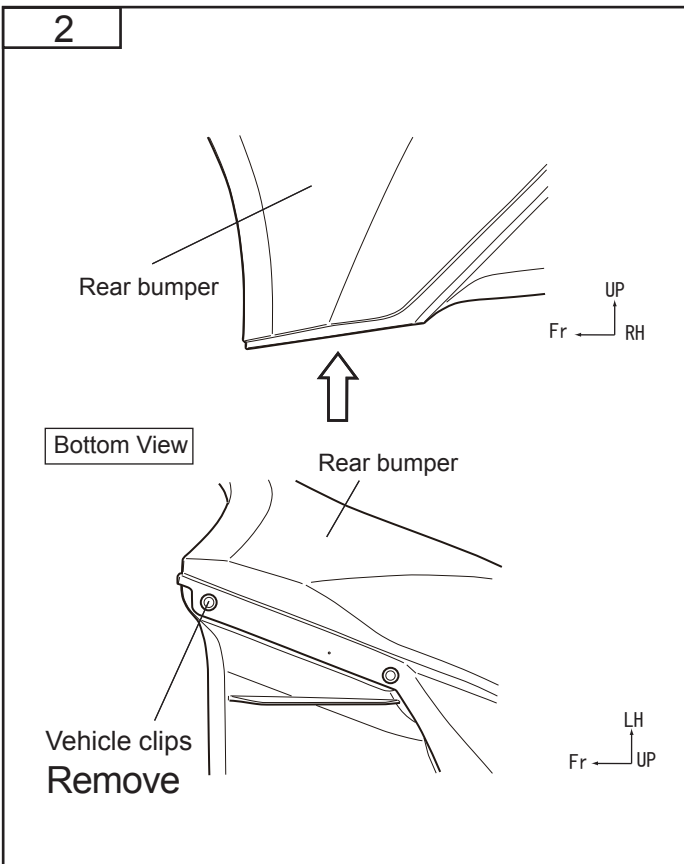

Remove the Vehicle clips

- 1.Remove the Vehicle clips.
(1 places on one side)

3

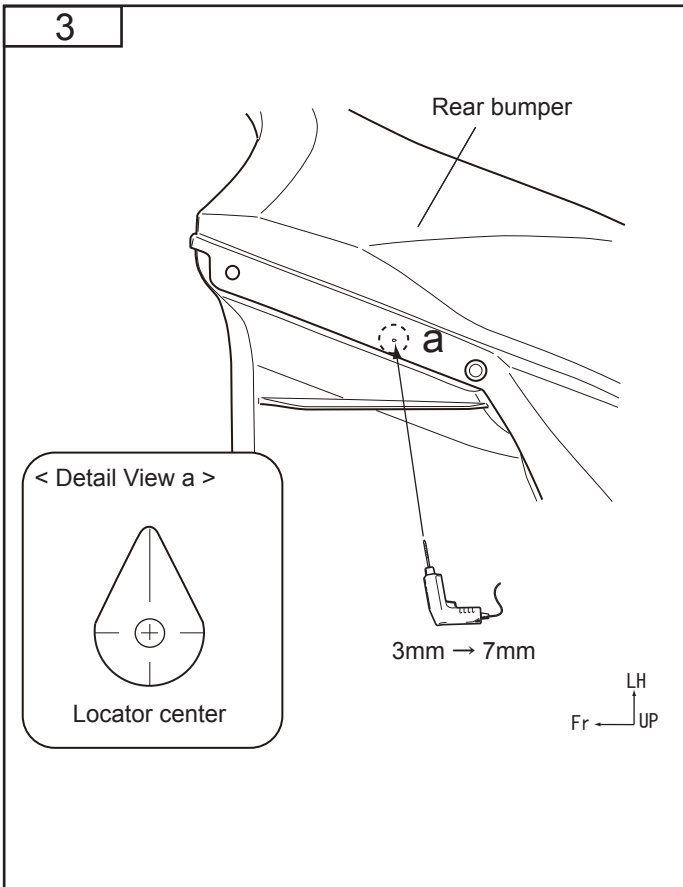

Drilling holes in the rear bumper

1. As shown in Fig. 3, apply a drill to the center of the locator on the underside of the rear bumper, make a pilot hole with 3 mm, and then make a 7 mm hole.

(1 places for each of RH and LH, 2 places in total)

Before drilling, make a stopper with cloth adhesive tape at a point about 5 mm from the tip of the drill so that the drill does not interfere with it.



4

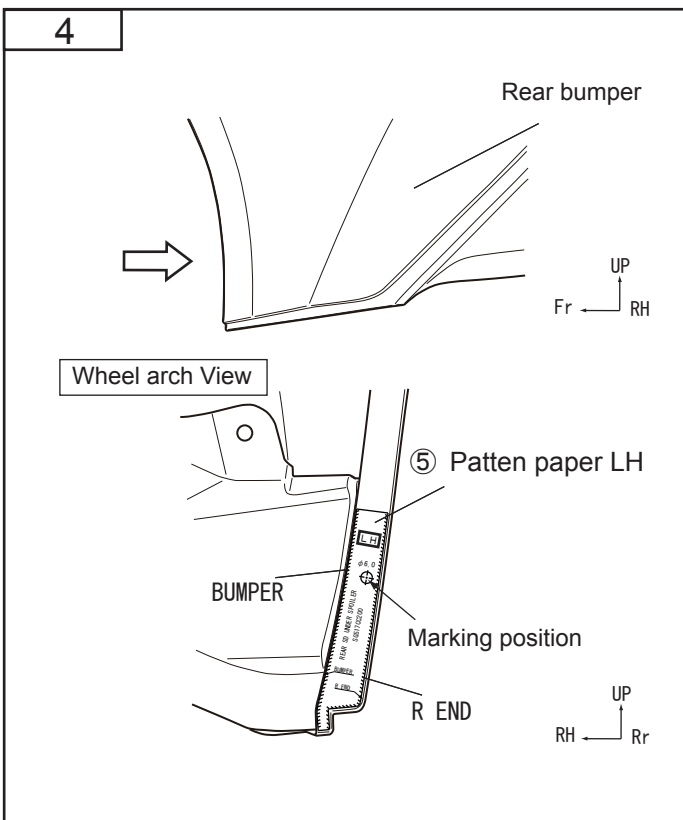

2. Carefully cut out ⑤ Pattern paper on the last page outside the line.

3. As shown in Fig. 4, use ⑤ Pattern paper and mark the center of the hole position with a drill or the like.

(1 places each for RH and LH, 2 places in total)

4. After marking, remove ⑤ Pattern paper.

5

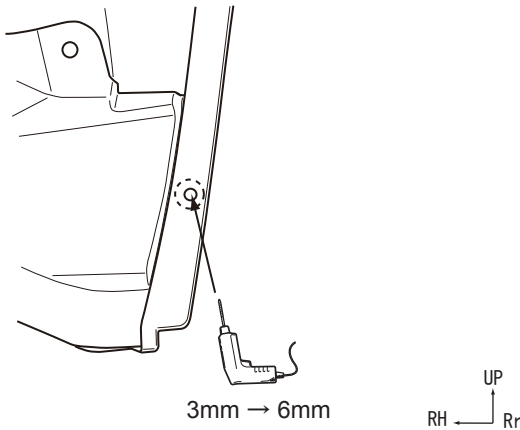

5. Make a hole with a pilot hole of 3 mm and a main hole of 6 mm at the center of the position marked in 3.
 (1 place each for RH and LH, 2 places in total)

Before drilling, make a stopper with cloth adhesive tape at a point about 5 mm from the tip of the drill so that the drill does not interfere with it.

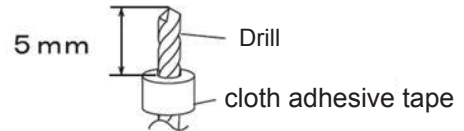

6

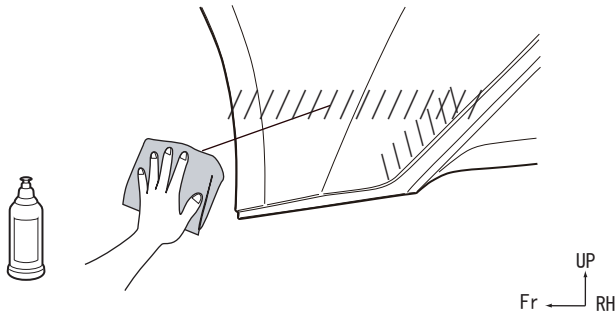

Degrease the Rear bumper

1. Degrease the shaded area in Fig. 6.

7

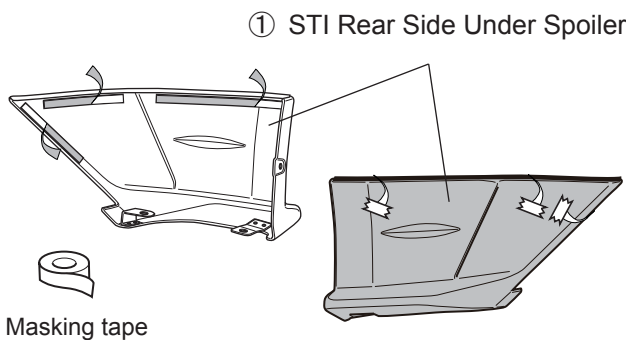

Installing the STI Rear Side Under Spoiler

1. Peel off the double sided tape release paper of the ① STI Rear Side Under Spoiler by about 30 mm and fix it on the front side with masking tape.
 (3 places each for RH and LH, 6 places in total)

Do not remove the release paper more than necessary.
 The double-sided tape clings to the peripheral parts, which makes it difficult to position them.

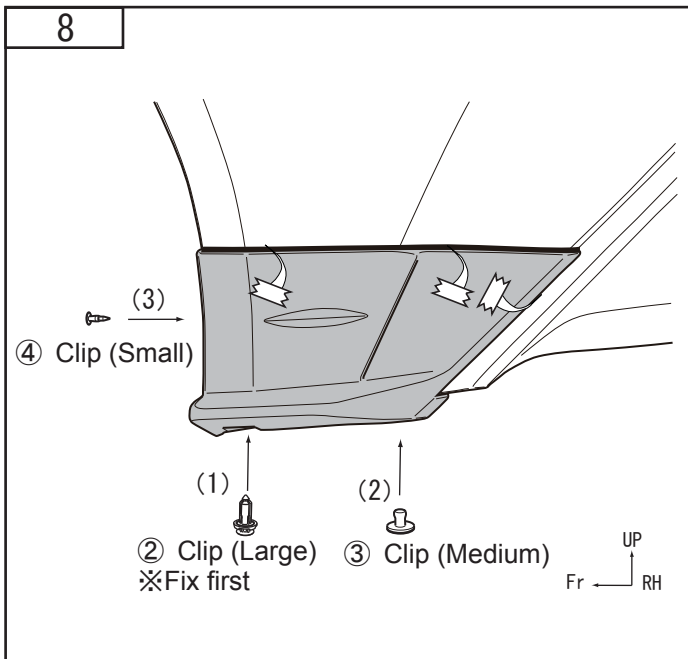

2. As shown in Fig. 8, apply ① STI rear side under spoiler, ② Clip (Large), ③ Clip (Medium), and finally ④ Clip (Small).
 (1 places each for RH and LH, 2 places in total)

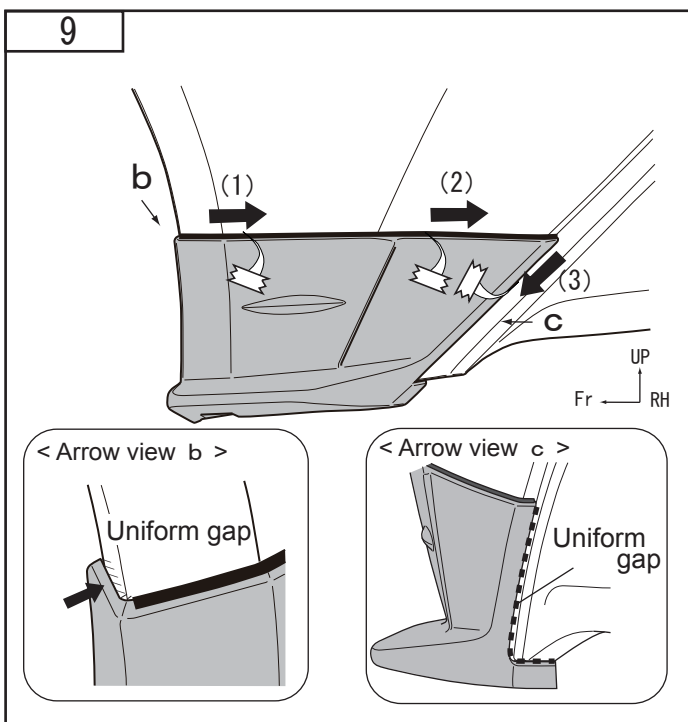

3. Position the gap evenly in the same way as arrows b and c.
 As shown in Fig. 9, crimp the double-sided tape in the order of (1) to (3) while slowly pulling out the paper pattern in the direction of the arrow so that it does not break in the middle.

If the release paper is difficult to pull out, slowly pull it out using radio pliers.

4. Fully re-bond the double-sided tape with 49N or more.

10

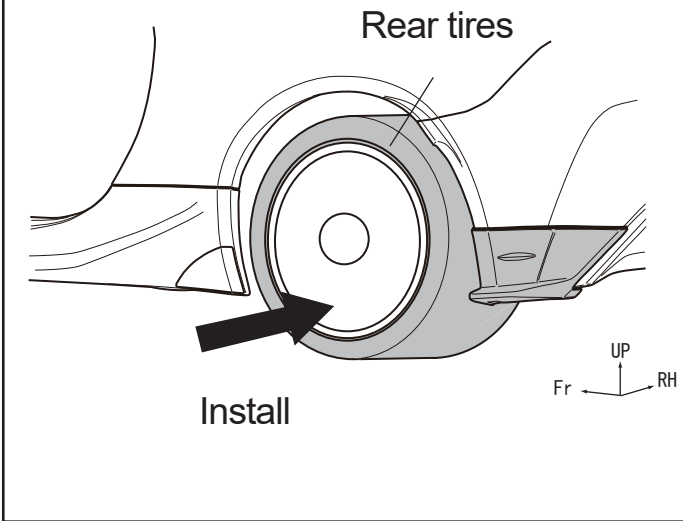

Install the Rear tires

1. Refer to the service manual and Install the rear tires on the vehicle.
(1 places each for RH and LH, 2 places in total)

This is the end of work.

Template for drilling holes on the rear bumper

- Please copy those templates to 1/1 scale.
- Cut the outside line of the templates.

