 <b>SUBARU</b> <b>INSTALLATION INSTRUCTIONS</b>	PART NUMBER: SPN0003352
	DESCRIPTION: Crosstrek Front Bumper Under Guard

**KIT CONTENTS:**

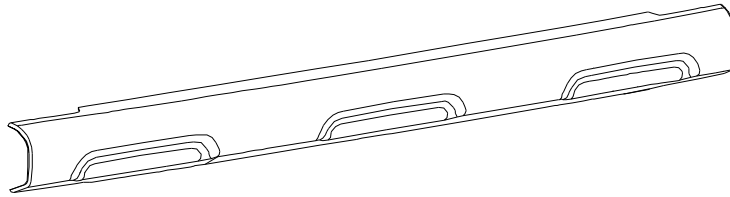

Front Bumper Under Guard x 1



Retainer Plug x 3



Alcohol Wipe x 1

**TOOLS REQUIRED:**

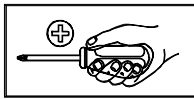

Philips Head  
Screwdriver



Masking Tape

**MEANING OF CHARACTERS:**



: Remove

T

: Tightening Torque



: Install



: Loosen



: Disconnect



: Discard



: Connect



: Reuse



: Location of Clip or Screw

DESCRIPTION Crosstrek Front Bumper Under Guard	ISSUE 01	DATE 11-07-19	SUBARU OF AMERICA	PAGE 1/4
---	-------------	------------------	-------------------	-------------

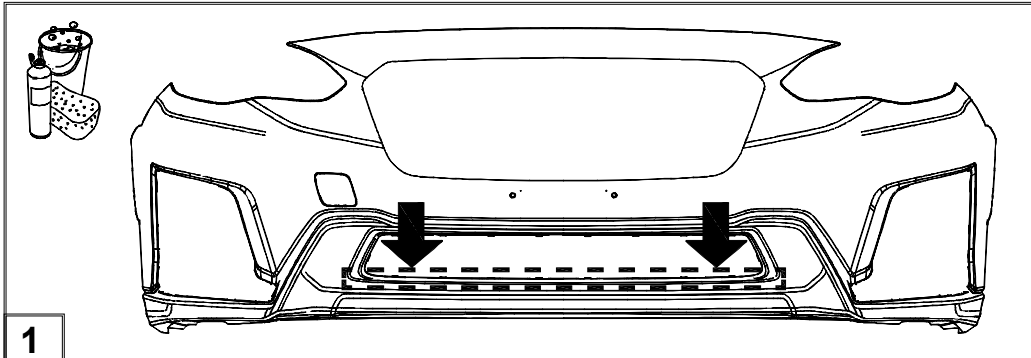
**Surface Preparation****1**

Make sure that all installation surfaces are clean, free of dirt, grease and debris using soap and water solution. Clean the indicated tape adhesion area with the alcohol wipe (provided).

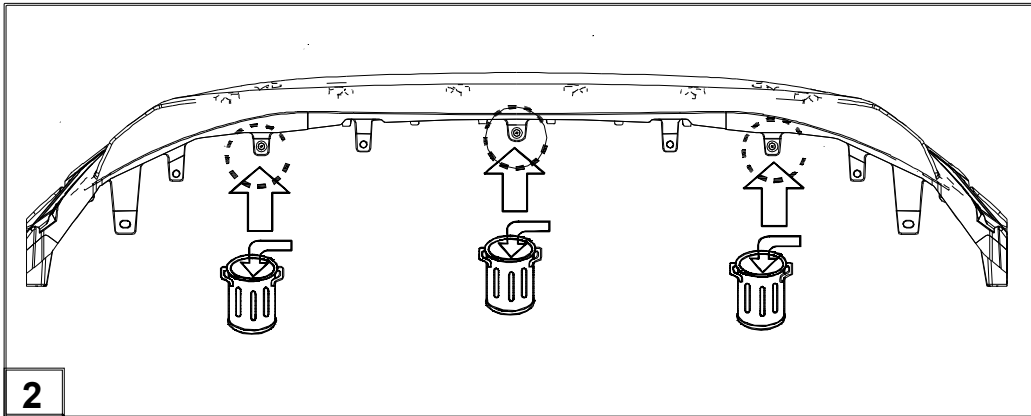
**Front Bumper Under Guard Installation****2**

Identify the (3) locations of the factory retainers in underside of bumper and remove with either Philips head screwdriver or plastic pry bar. Discard the 3 retainers.

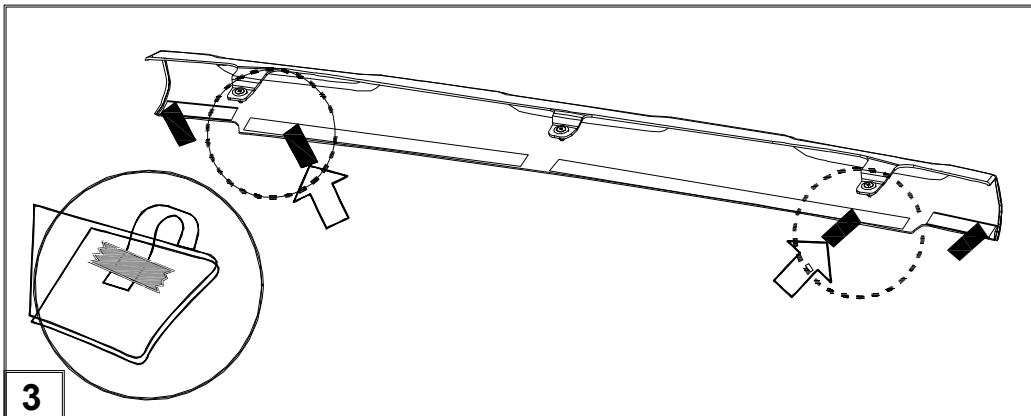
**3**

Peel back approx. 50mm / 2" of tape liner at each end of the part and fold at 45 degrees to part. Tape peeled back section of tape liner to outside surface of the bumper under guard using masking tape.

DESCRIPTION	ISSUE	DATE	SUBARU OF AMERICA	PAGE
Crosstrek Front Bumper Under Guard	01	11-07-19		2/4

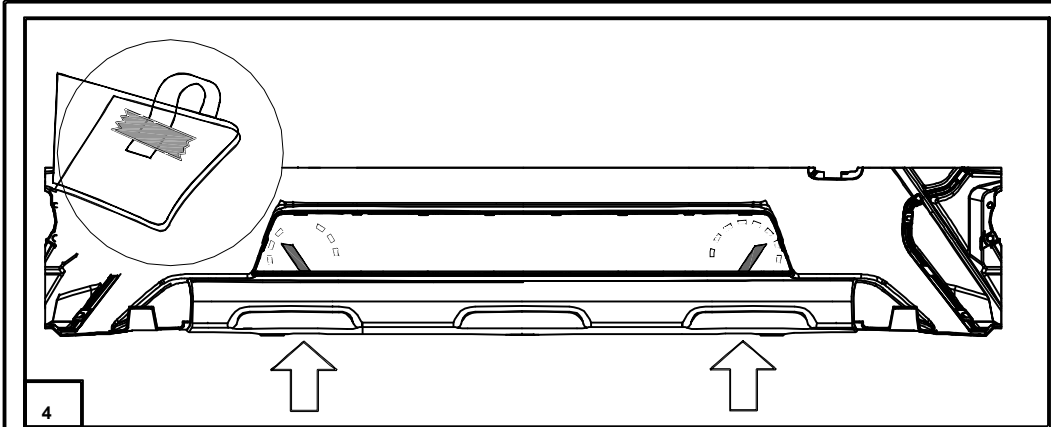

4

Install Front Bumper Under Guard in position of best fit ensuring that folded tape liners remains outside.

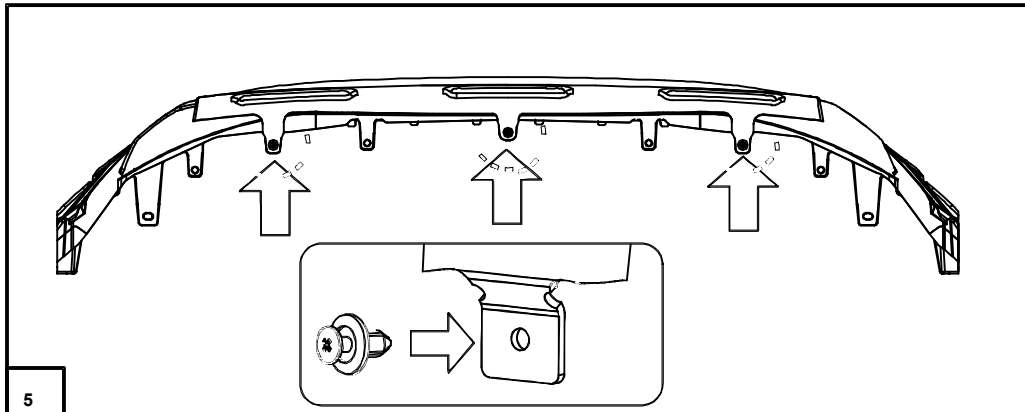

5

Install (3) provided replacement retainer plugs in (3) available holes in Front Bumper Under Guard.

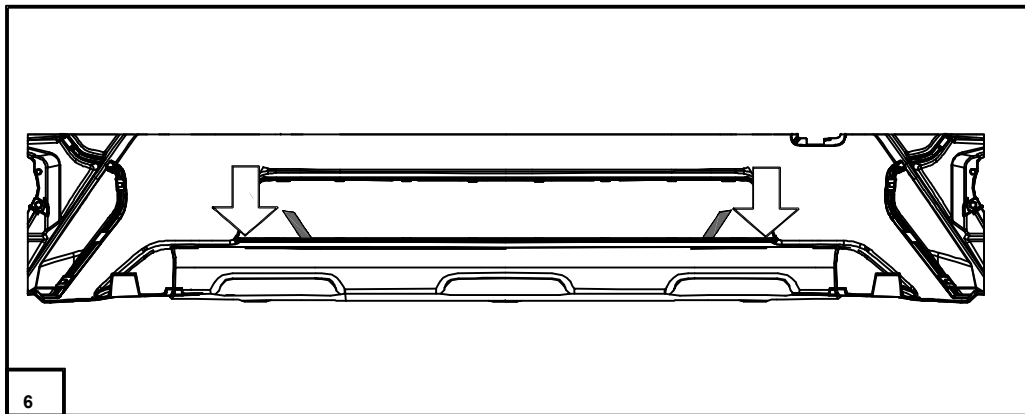

6

Under Guard where the double sided tape liner has been removed, (as shown).

DESCRIPTION	ISSUE	DATE	SUBARU OF AMERICA	PAGE
Crosstrek Front Bumper Under Guard	01	11-07-19		3/4

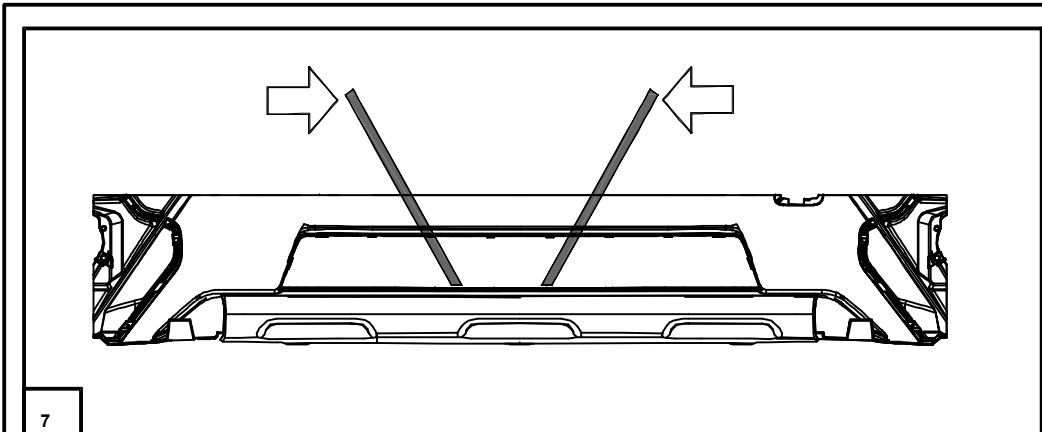

7

While applying moderate forward pressure towards bumper, pull exposed tape liners towards opposite end of Front Bumper Under Guard, one side at a time (as shown).

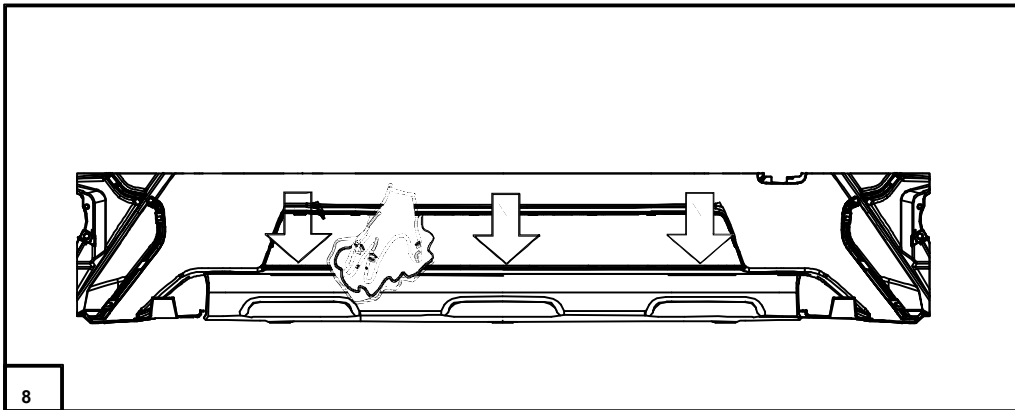

8

side to side approx. 5 times to ensure proper tape adhesion is achieved.

DESCRIPTION	ISSUE	DATE	SUBARU OF AMERICA	PAGE
Crosstrek Front Bumper Under Guard	01	11-07-19		4/4