



STI Pedal pad set (AT) installation/instruction manual



1. Be sure vehicle is parked in gear with the parking brake on.
2. Be sure tighten fasteners including bolts and nuts to the specified torque.
3. This part is used an adhesion bond called "Thread lock".
When you fix the nut to the bolt, it will completely harden in 30 minutes.
It is one time use only. If you temporarily fix the bolt, please fully tighten it within 5 minutes.

Installation procedures

1. Part number and applicable vehicle model

STI part number	Part name	Applicable vehicle model
C8110FG001 (LHD)	Pedal pad set (AT)	IMPREZA GH/GE A- LEGACY BL/BP D- (2.5L turbo, 2.5L, 3.0L) FORESTER SH A-

*This product cannot be installed to the vehicle with an aluminum pedal.

2. Specifications

(1) Material

- Pedal pad : aluminum
- Embossed pedal : synthetic rubber
- Bracket : steel
- Bolt and nut : stainless

(2) Complete part

(*Check the quantities. In case there is a shortage or difference from the list, please contact the dealer where you made the purchase.)

	Part name	Quantity		Part name	Quantity
①	Accelerator pedal pad	1	⑧	Cap nut M3	1
②	Brake pedal pad (AT)	1	⑨	Flat-head screw M4 x 10	1
③	Accelerator embossed pedal	1	⑩	Flat-head screw M4 x 6	1
④	Brake embossed pedal (AT)	1	⑪	Flat-head screw M4 x 16	2
⑤	Accelerator bracket	1	⑫	Nut M4	2
⑥	Brake bracket (AT)	1	⑬	Collar (LHD only)	1
⑦	Cap screw M3 x 42	1	⑭	Installation/instruction manual	1

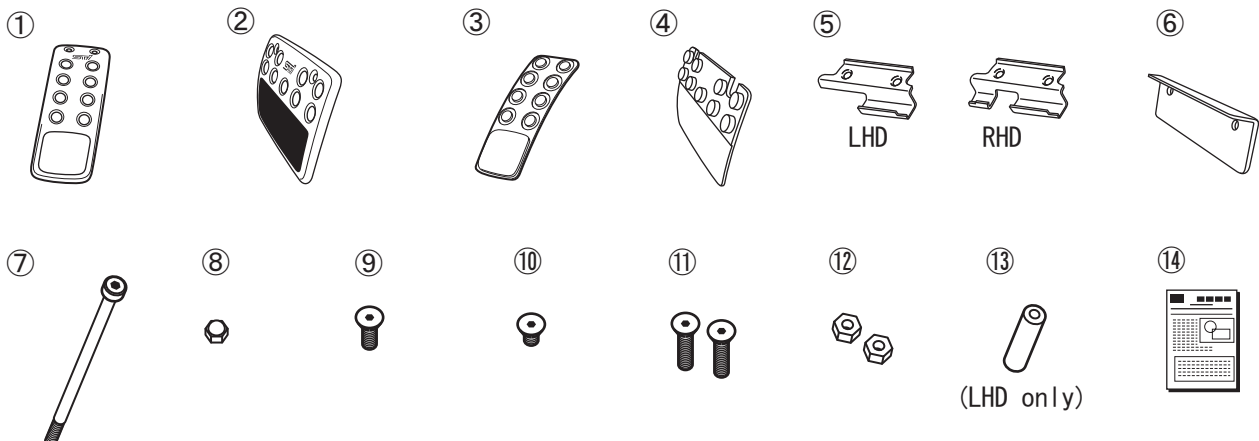

3. Tool

■ Allen key (2.5mm)

■ Wrench (7mm)

■ Wrench (5.5mm)

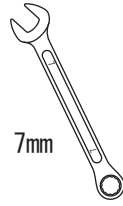

4. Completion drawing of the installation

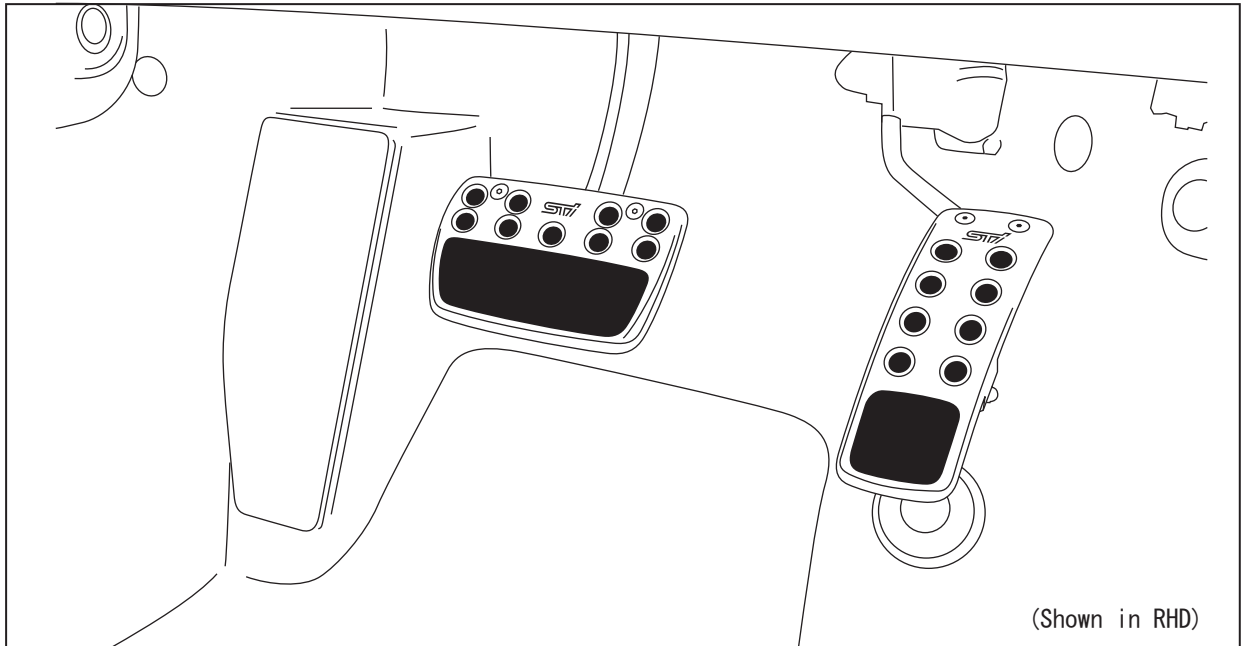

5. Installation procedures

Installation of accelerator pedal

(1) Clean the OE accelerator pedal.

(2) Fit ③ accelerator embossed pedal into ① accelerator pedal pad.

(3) Set ⑤ accelerator bracket on the upper side of the OE accelerator pedal by covering it from the back.

① Accelerator pedal pad

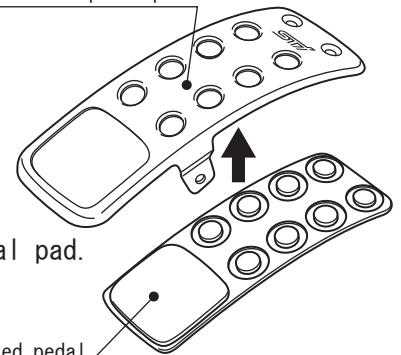

⑤ Accelerator bracket

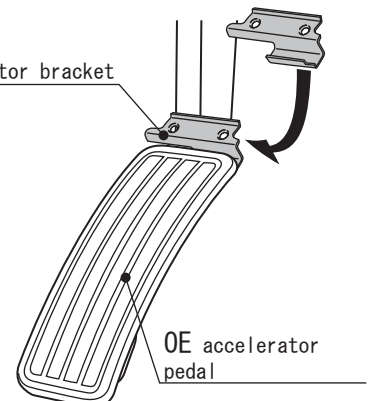

- (4) Set ① accelerator pedal pad on the OE accelerator pedal from the bottom.

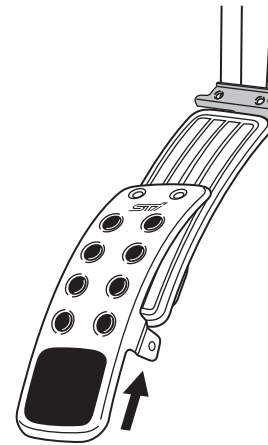

⑨ Flat-head screw M4 x 10

- (5) Temporarily tighten ① accelerator pedal pad and ⑤ accelerator bracket with ⑨ flat-head screw M4 x 10 and ⑩ flat-head screw M4 x 6.

* For L.H.D. vehicle, temporarily tighten it on the left side position.

⑩ Flat-head screw M4 x 6

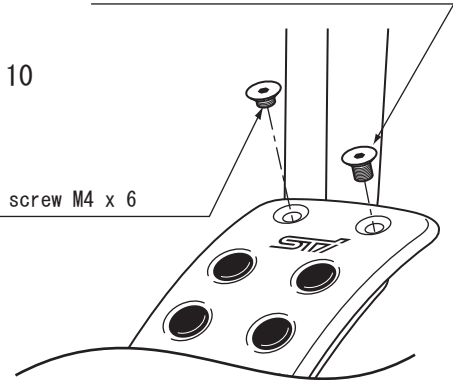

- (6) Insert ⑦ cap screw M3 x 42 to the prepared hole of the bolt on the side of ① accelerator pedal pad from the left side to the right side, then attach ⑧ cap nut. After checking the right and left positions (L.H.D. vehicle - the left position) of the accelerator pedal pad, tighten the cap screw until it reaches the bottom of the cap nut.

CAUTION

- Make sure to insert the screw from the left side to the right side.
- For L.H.D. vehicle, the pedal pad may interfere to vehicle floor parts if it is not on the left side position.

⑦ Cap screw M3 x 42

⑦ Cap screw M3 x 42

⑬ Collar

⑧ Cap nut M3

Tightening torque of a cap screw
 $1.5 \pm 0.5 \text{ Nm}$
 $(1.1 \pm 0.37 \text{ lb-ft})$

⑬ Collar

Set the collar not to get onto the reinforcement of the back side

• This procedure is only for LHD.

- (7) Fully tighten ⑨ flat-head screw M4 x 10 and ⑩ flat-head screw M4 x 6 which are temporarily tightened in (5).

Tightening torque $2.16 \pm 0.5 \text{ Nm}$
 $(1.59 \pm 0.37 \text{ lb-ft})$

CAUTION

- Make sure to adjust the pedal pad position appropriately where it does not interfere with any interior parts especially when it is at full stroke.

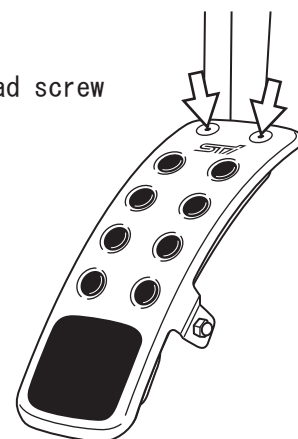

Installation of brake pedal

- (1) Remove the rubber cover of the OE brake pedal by peeling the upper side.

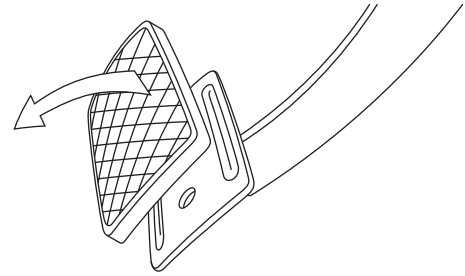

- (2) Fit ④ brake embossed pedal (AT) into ② brake pedal pad (AT).

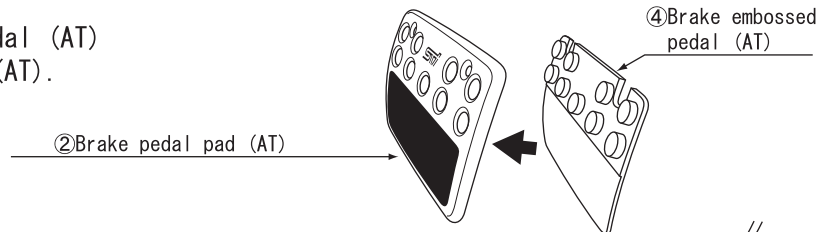

- (3) Clean the OE pedal.

- (4) Insert the U-shaped groove on the underside of ② brake pedal pad (AT) to the genuine brake pedal from the bottom.

Insert the U-shaped groove first.

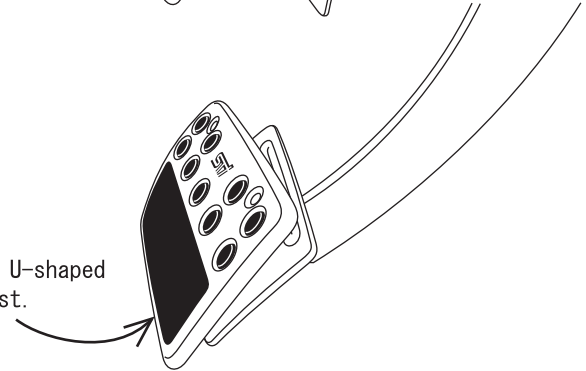

- (5) Set ⑥ brake bracket (AT) on the upper back of the OE brake pedal, and temporarily tighten with ⑪ flat-head screw M4 x 16 and ⑫ nut M4.

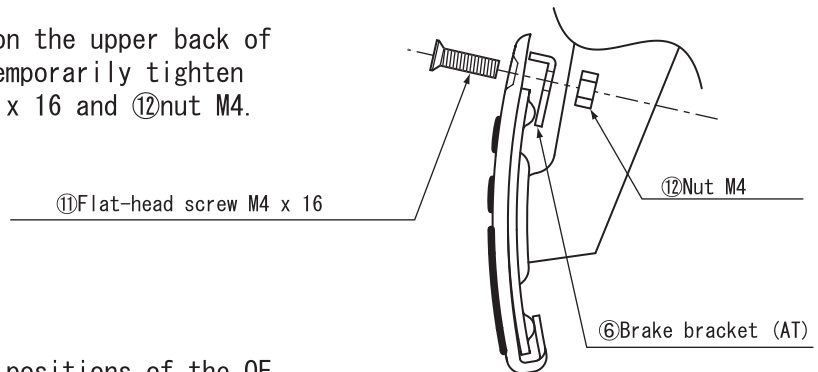

- (6) Adjust the right and left positions of the OE pedal and pedal pad to be even by using a mirror. Then, fully tighten the bolt and nut.

Tightening torque $2.16 \pm 0.5 \text{ Nm}$
($1.59 \pm 0.37 \text{ lb-ft}$)

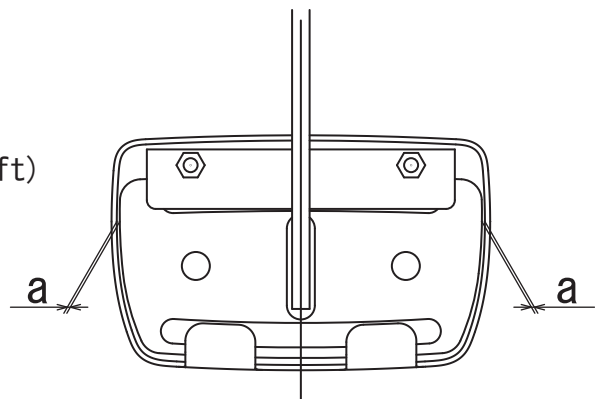

It is the end of the installation.