

STI CVT SHIFT KNOB

TOOLS REQUIRED:

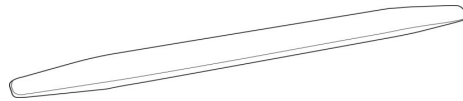

Plastic Trim Removal Tool

PARTS IDENTIFICATION:

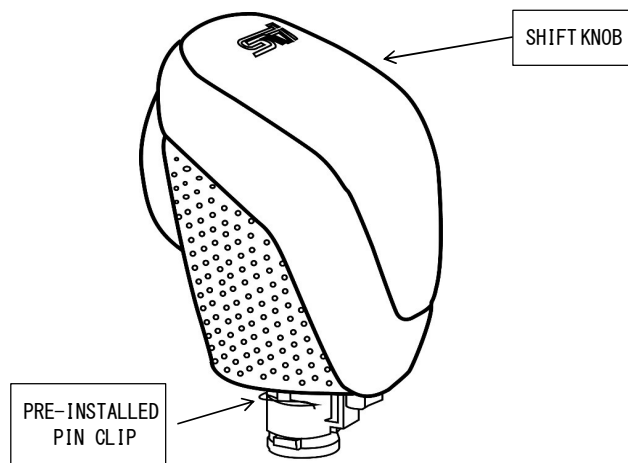

STEP 1: Park vehicle on level surface. Apply parking brake. Place vehicle in "P" Park.

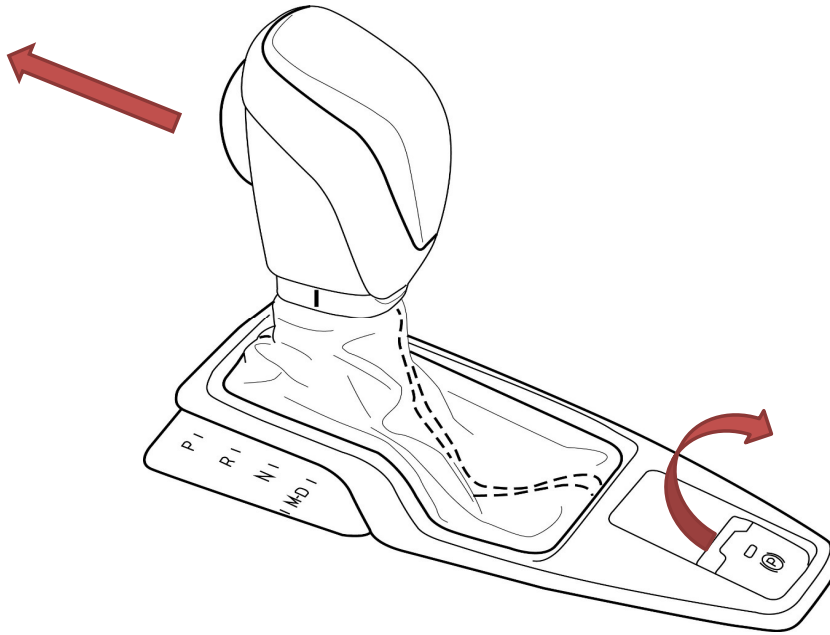

STEP 2: Use plastic trim removal tool to pry and push down on the factory cover grip.

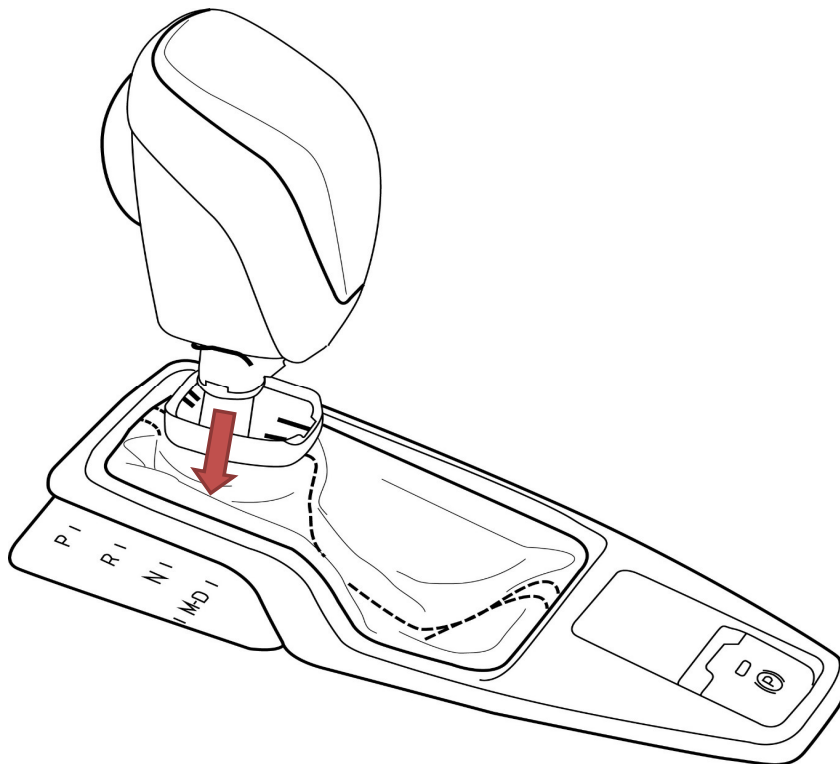



STEP 3: Use fingers to push pin clip forward on both sides. Remove OE shift knob.

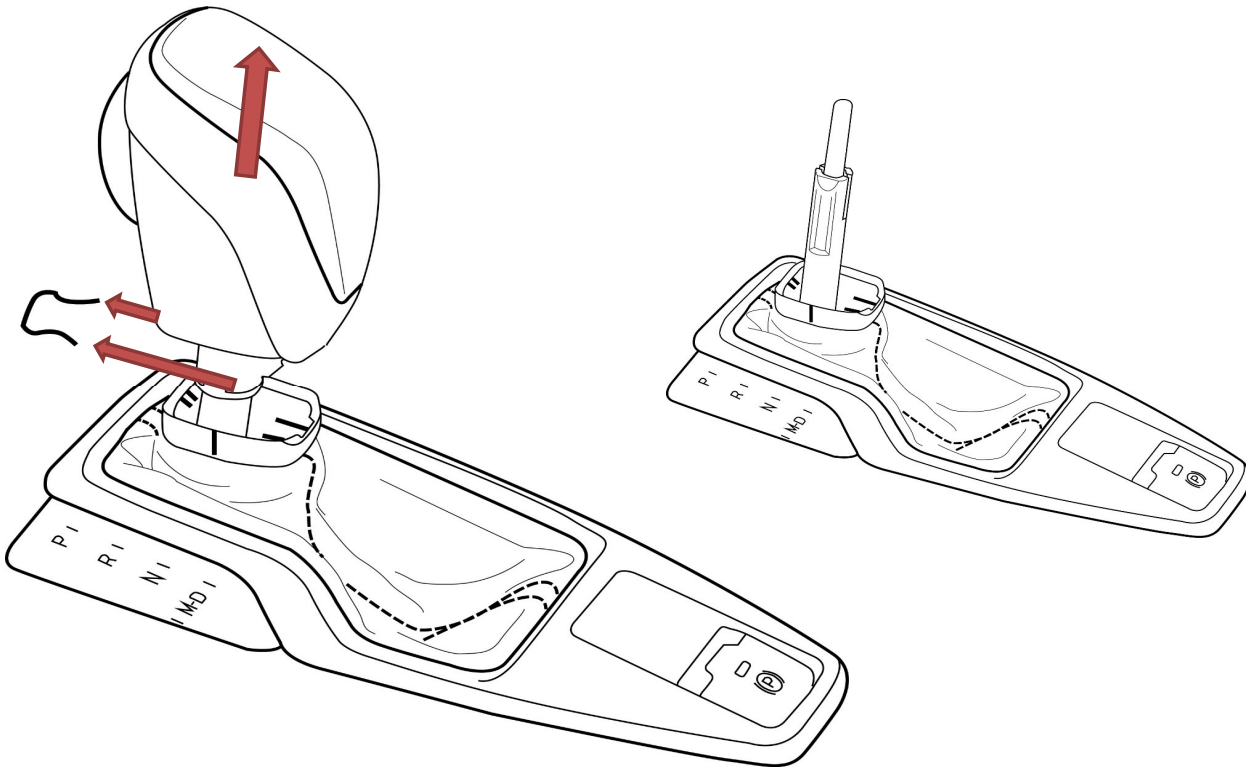

STEP 4: Check to make sure pre-installed pin clip is still installed on the STI CVT Shift Knob. NOTE: Place your finger over the pin clip. Carefully align and position shift knob and then push down until a click is heard. CAUTION: If your finger is not placed over the pin clip during the downward push, the pin clip may eject and get lost. If the pin clip comes loose, you can still install it by holding down the shift knob while inserting the pin clip towards the back of the vehicle until it engages.

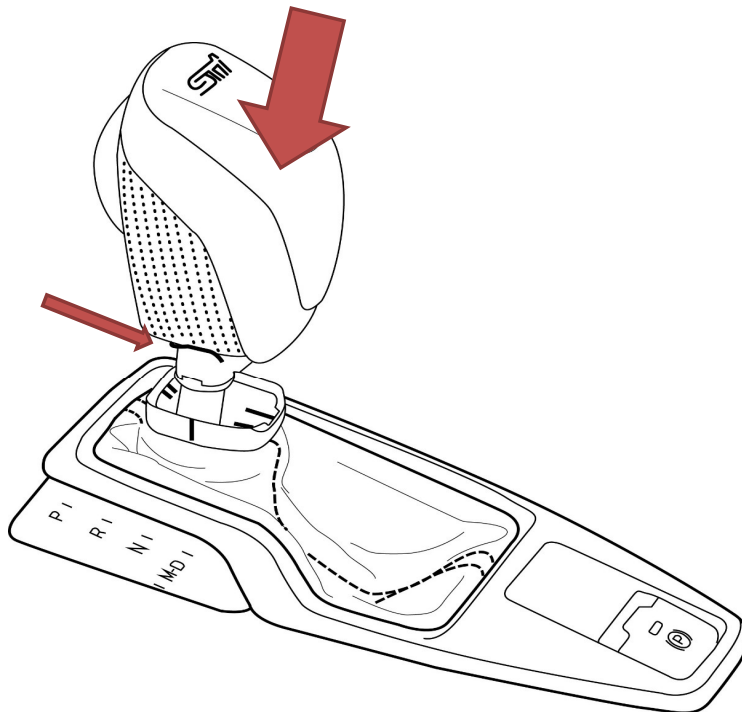

STEP 5: While holding down shift knob, pull the cover grip upward until a click is heard.

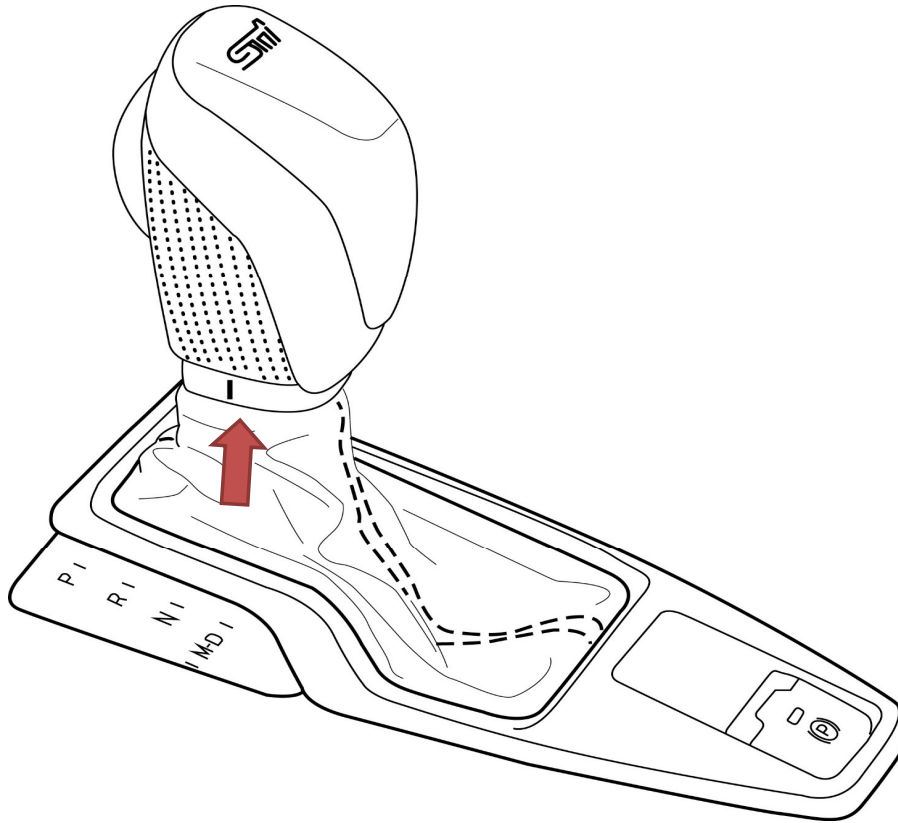

STEP 6: Depress brake pedal. Confirm that the shift knob is firmly installed and that the button can be fully depressed. Make sure the shift knob is properly installed before operating the vehicle. Turn on ignition, depress and hold brake pedal, confirm shift lever cannot shift out of "P" without depressing button. Confirm shift lever function by checking engagement into Reverse and MD modes.

