



**SUBARU**

**PART NUMBER: C1010FL010**

**INSTALLATION INSTRUCTIONS**

**DESCRIPTION: STI CVT SHIFT KNOB**

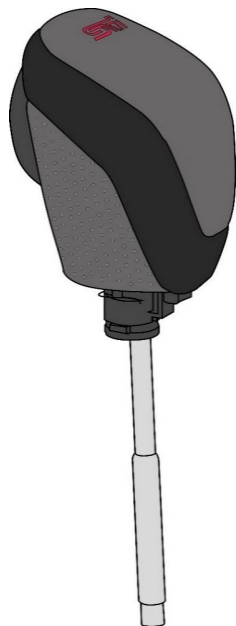

**STI CVT SHIFT KNOB**

**TOOLS REQUIRED:**

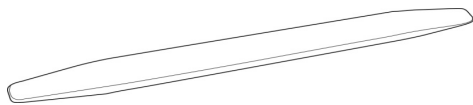

Plastic Trim Removal Tool

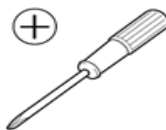

Phillips Screwdriver  
(for vehicles w/ shift boot)

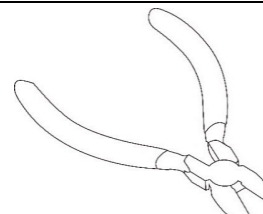

Wire Cutter

**PARTS IDENTIFICATION:**

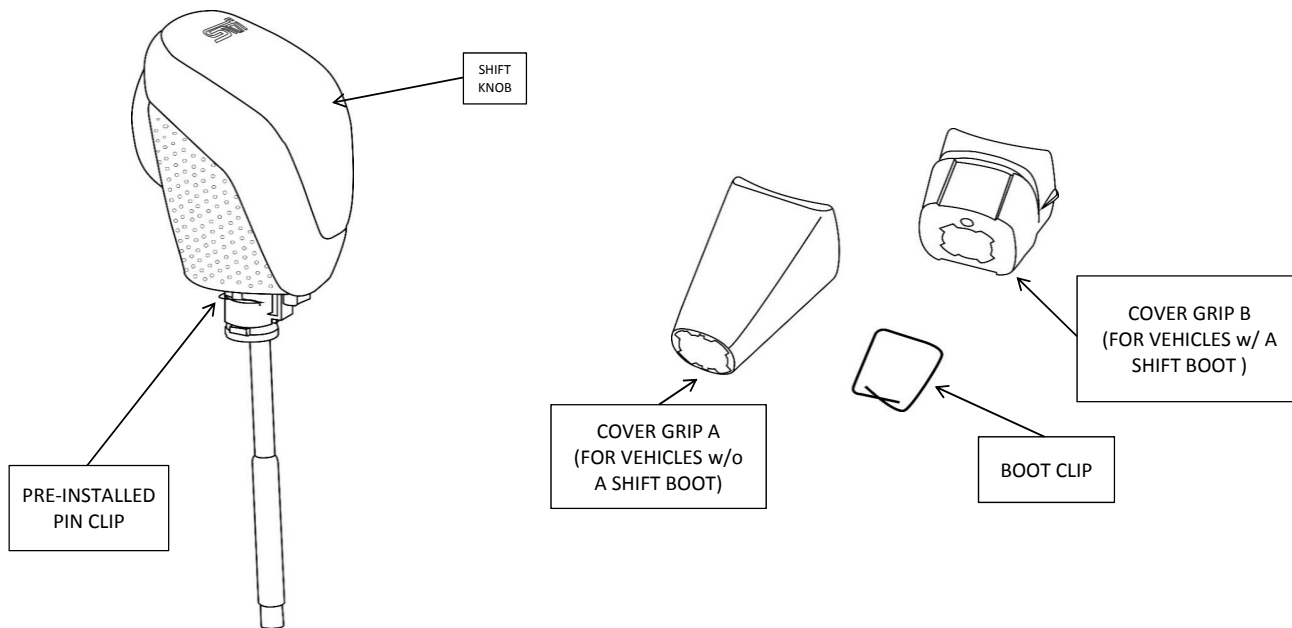

PART NUMBER:  
C1010FL010

ISSUE  
01

8/24/2016

**SUBARU OF AMERICA**

PAGE 1 / 14

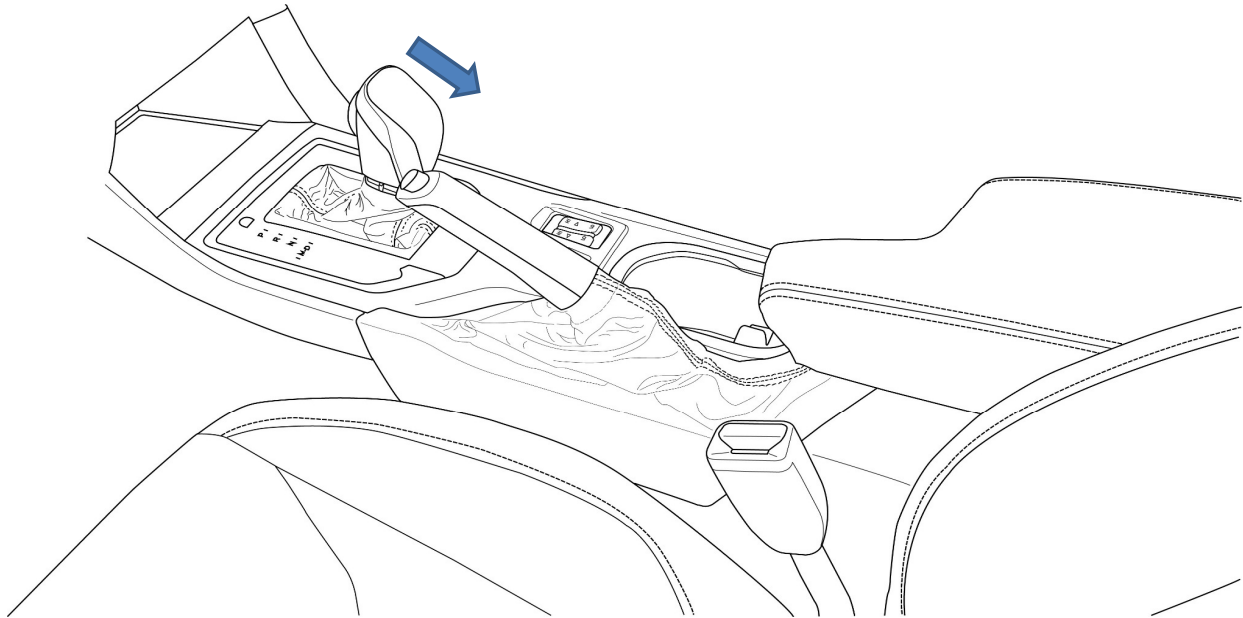
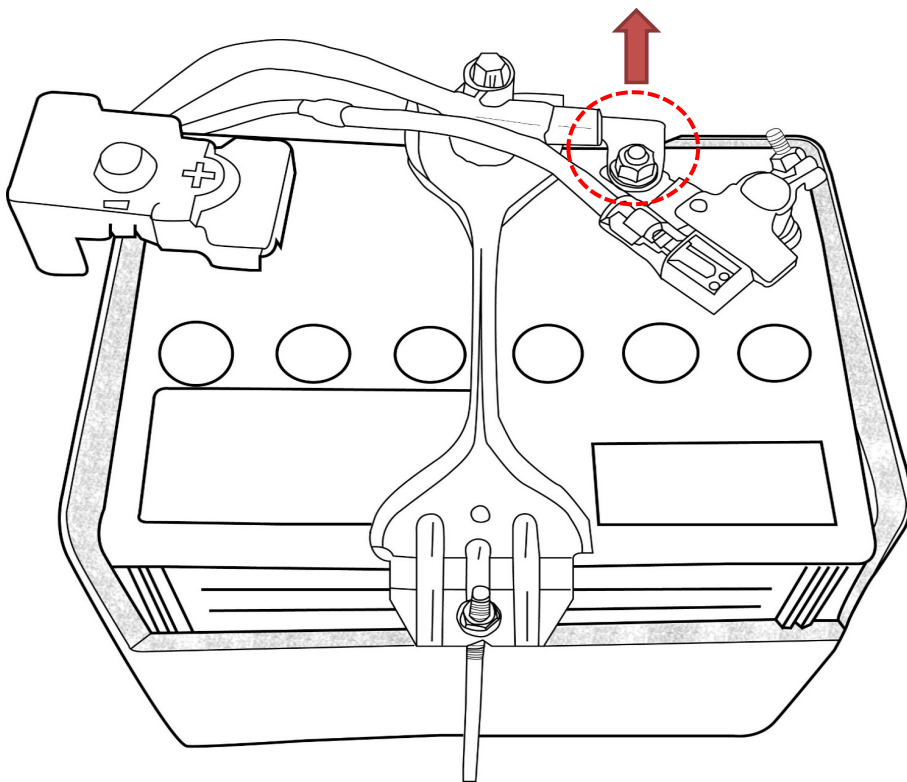
**FOR VEHICLES WITH A SHIFT BOOT (Page 2 - Page 11)****STEP 1:** Park vehicle on level surface. Apply parking brake. Move shift lever to "N" and turn ignition off.**STEP 2:** Disconnect negative battery cable shown in the figure below. Do not disconnect the cable connected to the battery terminal.

**FOR VEHICLES WITH A SHIFT BOOT (Page 2 - Page 11)**

**STEP 3:** Open armrest.

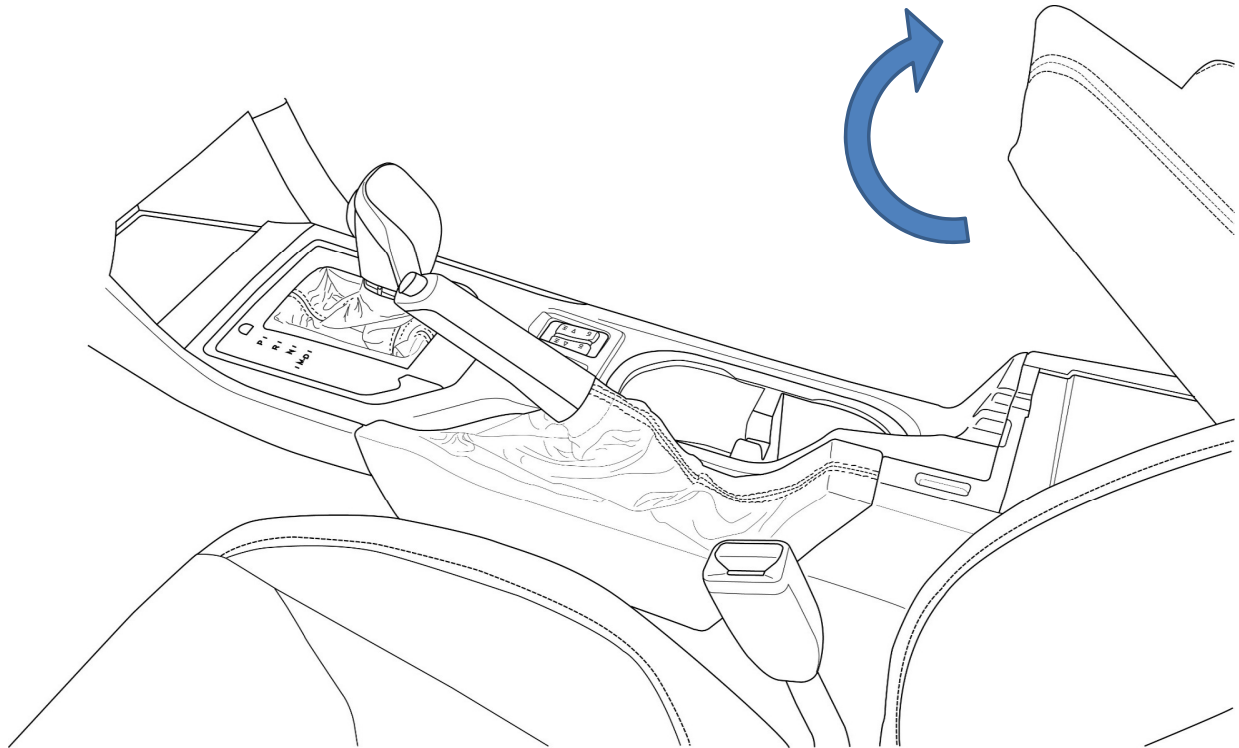

**STEP 4:** Use plastic trim removal tool and pop up the rear of the center console. Remove the parking brake cover by pulling straight up on the areas indicated below.

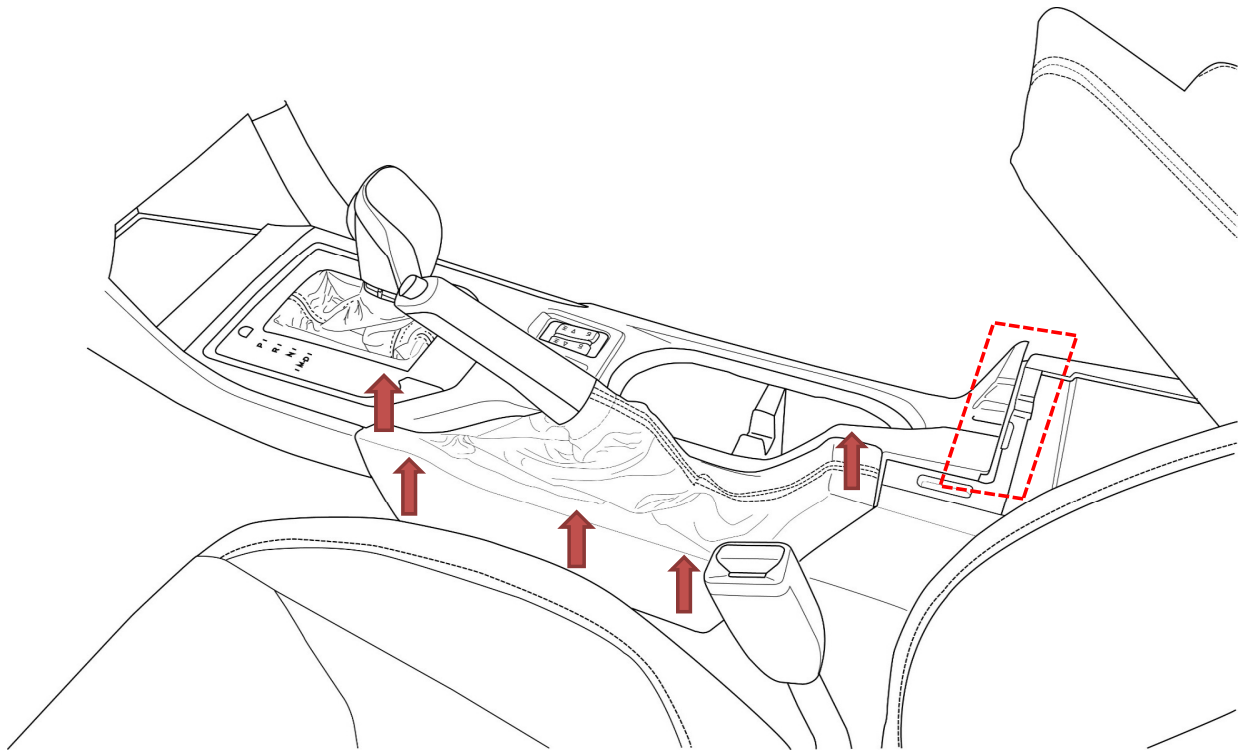

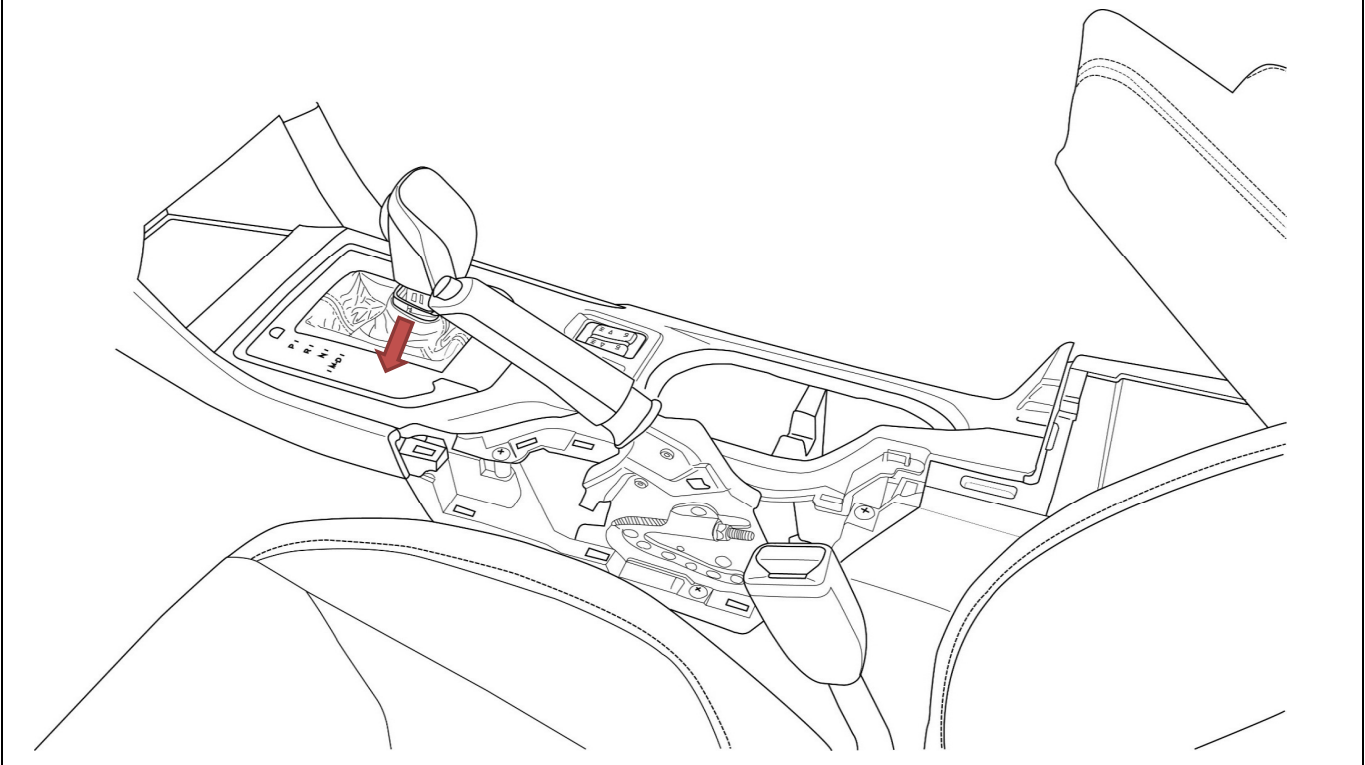
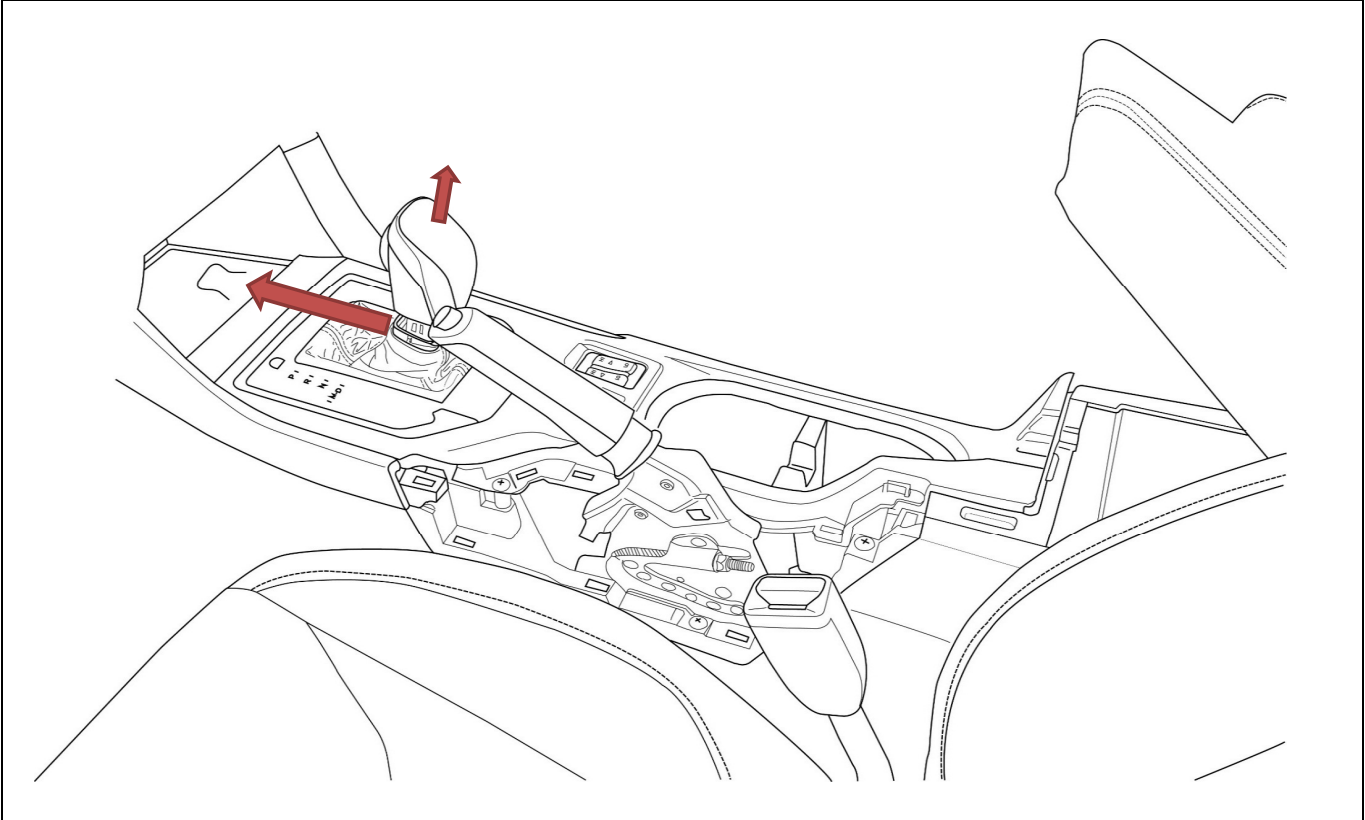
**FOR VEHICLES WITH A SHIFT BOOT (Page 2 - Page 11)****STEP 5:** Use plastic trim removal tool to pry and push down on the factory cover grip.**STEP 6:** Use fingers to push pin clip forward on both sides. Remove OE shift knob.

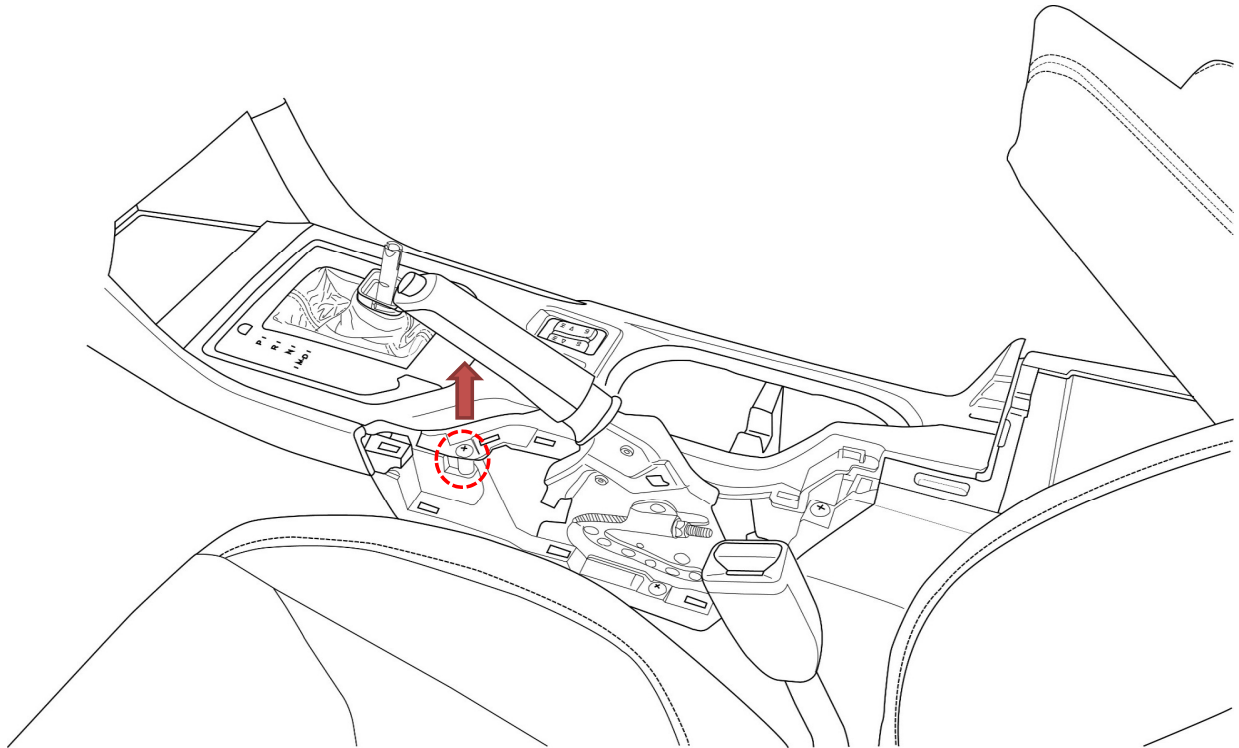
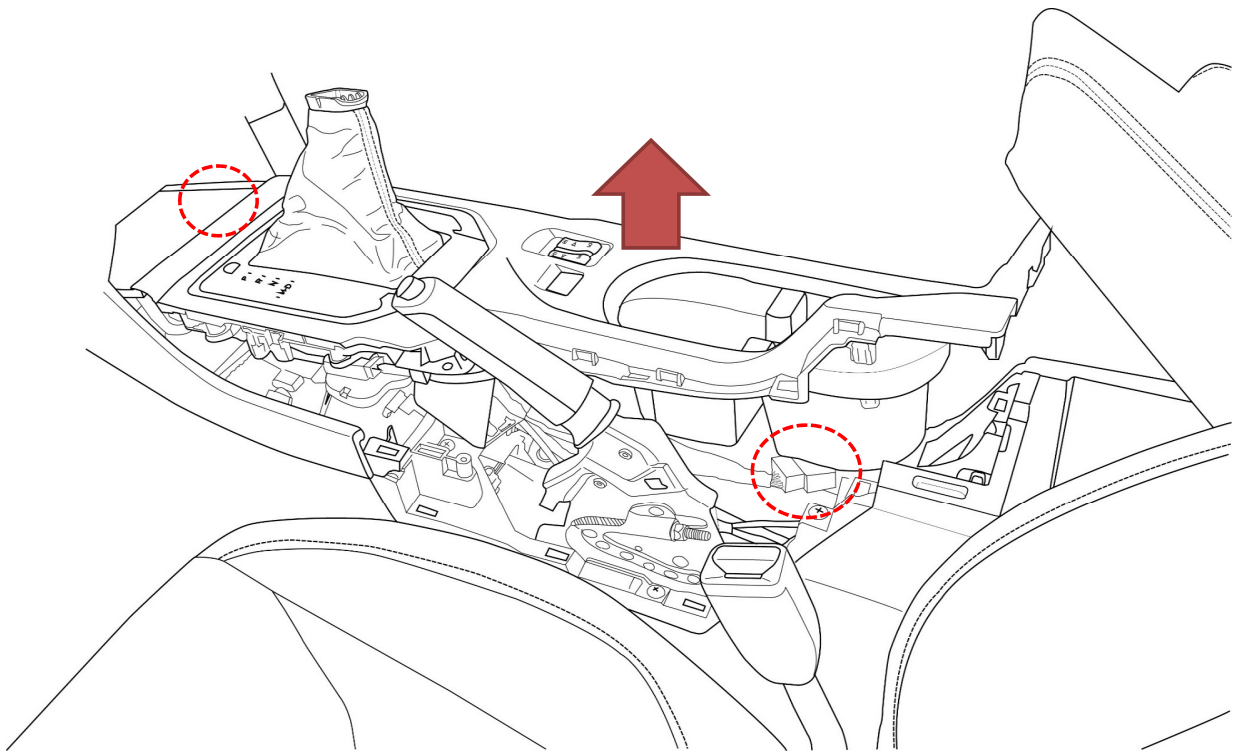
**FOR VEHICLES WITH A SHIFT BOOT (Page 2 - Page 11)****STEP 7:** Use a phillips screwdriver to remove screw indicated in figure below.**STEP 8:** Carefully lift up the center console and disconnect two connectors indicated in the figure below. One connector will be located near the parking brake and armrest. The second connector is located under the front tray.

**FOR VEHICLES WITH A SHIFT BOOT (Page 2 - Page 11)**

**STEP 9:** Bring center console to a soft working surface and flip over. **CAUTION:** The shift boot bezel can become scratched if placed on a rough surface.

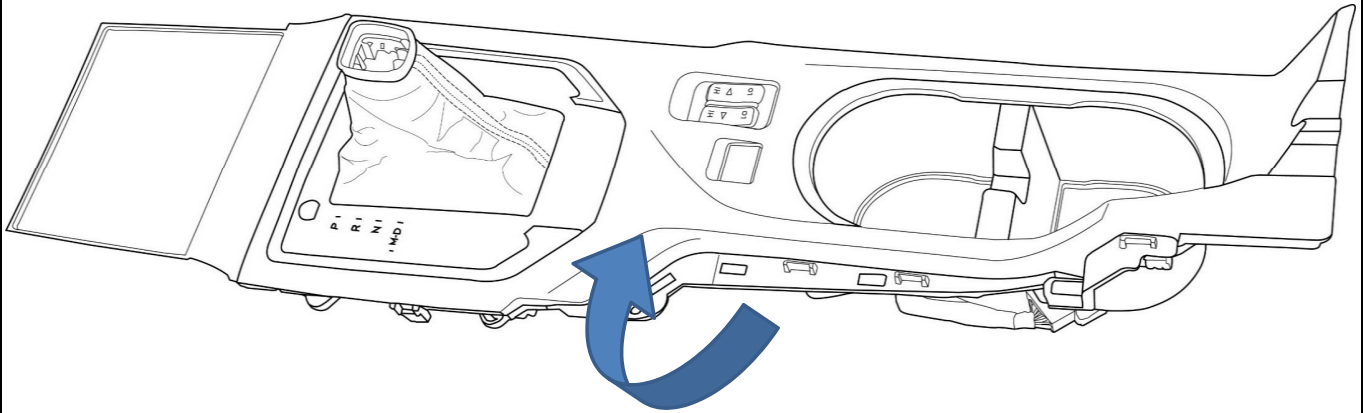

**STEP 10:** Carefully push in the four tabs below to remove the shift boot assembly.

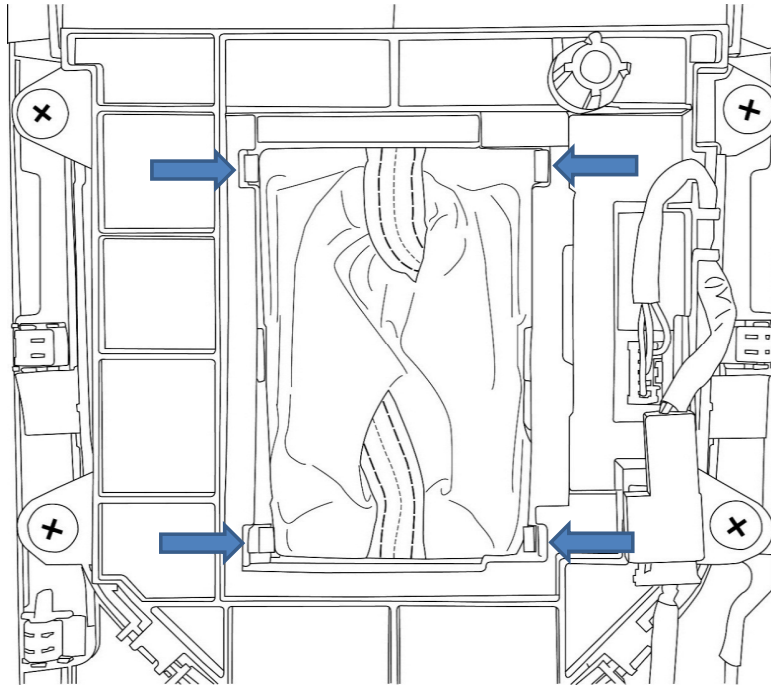

**STEP 11:** Push shift boot assembly down to invert.

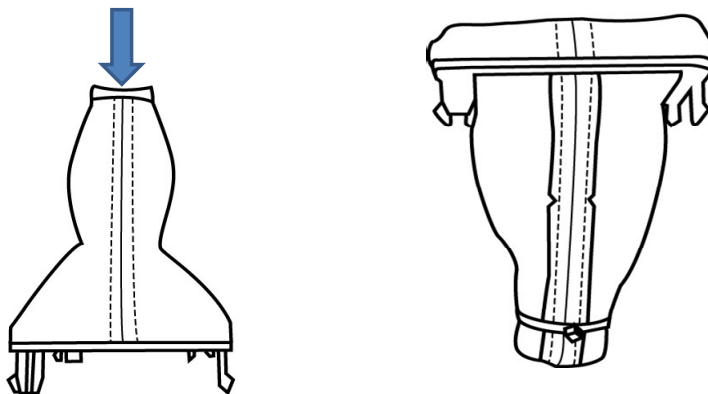

**FOR VEHICLES WITH A SHIFT BOOT (Page 2 - Page 11)**

**STEP 12:** Use wire cutter to cut cable tie. **CAUTION:** Make sure the wire cutter doesn't cut the shift boot. Remove factory cover grip.

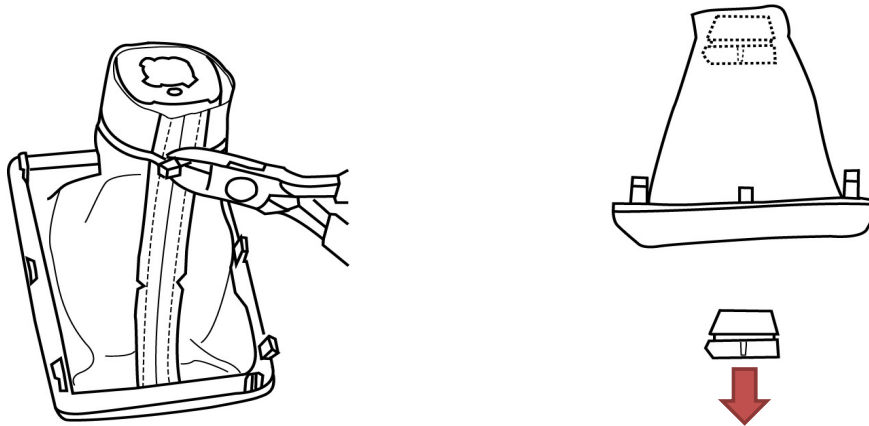

**STEP 13:** Insert the included Cover Grip B within the shift boot. Align the recessed circular marking with the notch in the shift boot stitching.

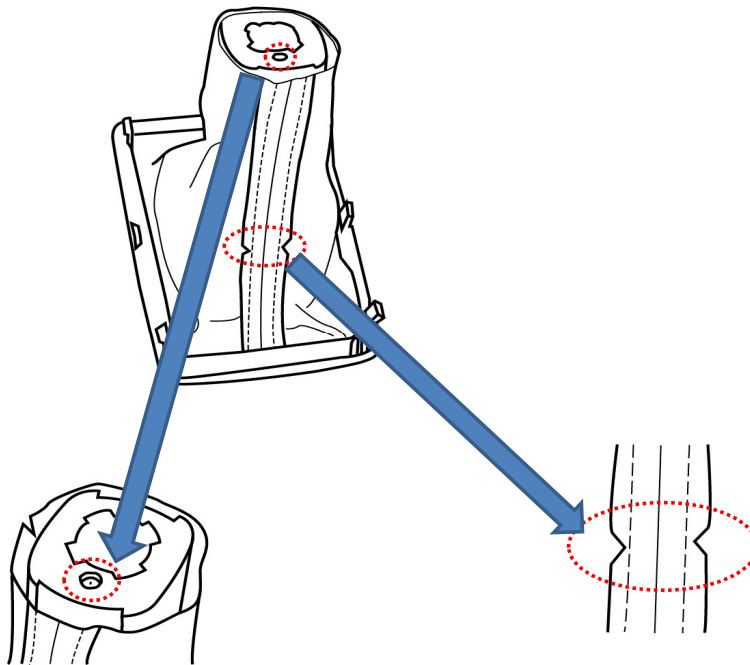

**STEP 14:** Install the included boot clip. Use plastic trim removal tool to push clip into its slot.

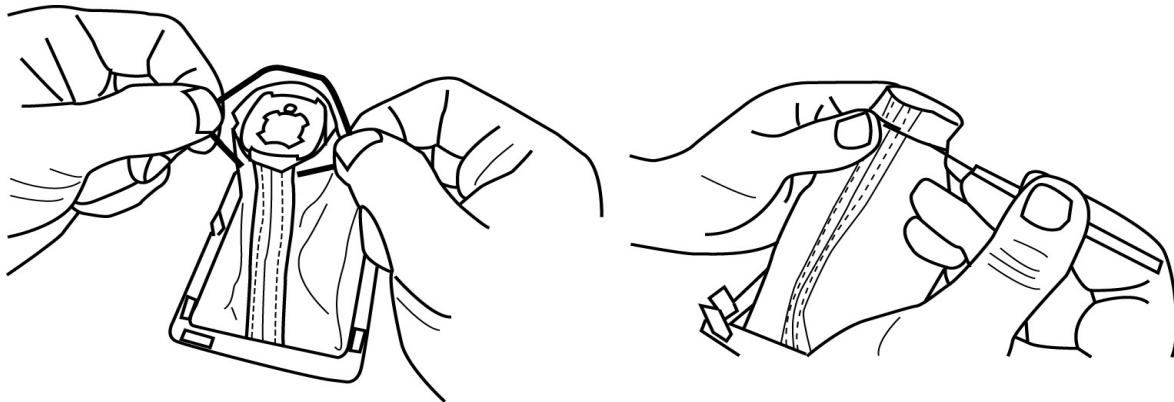

**FOR VEHICLES WITH A SHIFT BOOT (Page 2 - Page 11)**

**STEP 15:** Check boot clip and cover grip positioning.

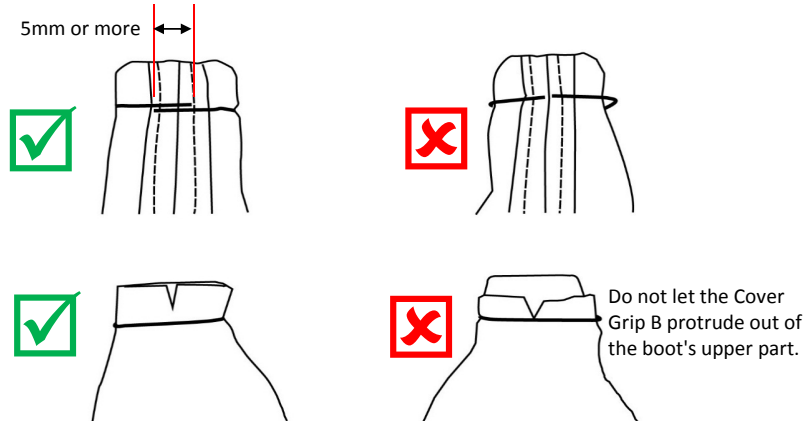

**STEP 16:** Invert boot back to normal position and check that the center of the Cover Grip B and the shift boot are aligned with the stitching.



**STEP 17:** Re-install shift boot back into center console. Make sure tabs fully engage.

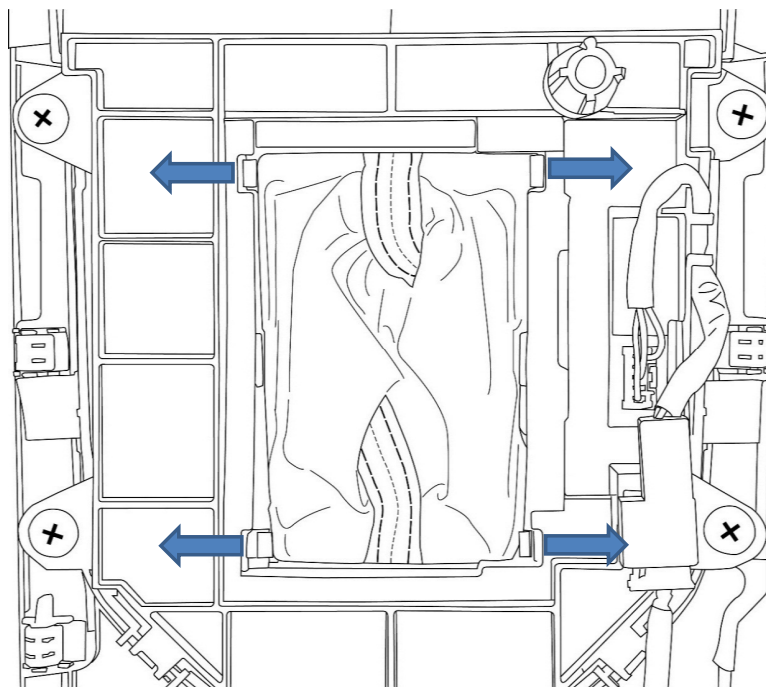



**FOR VEHICLES WITH A SHIFT BOOT (Page 2 - Page 11)**

**STEP 18:** Loosely position center console and reconnect two connectors.

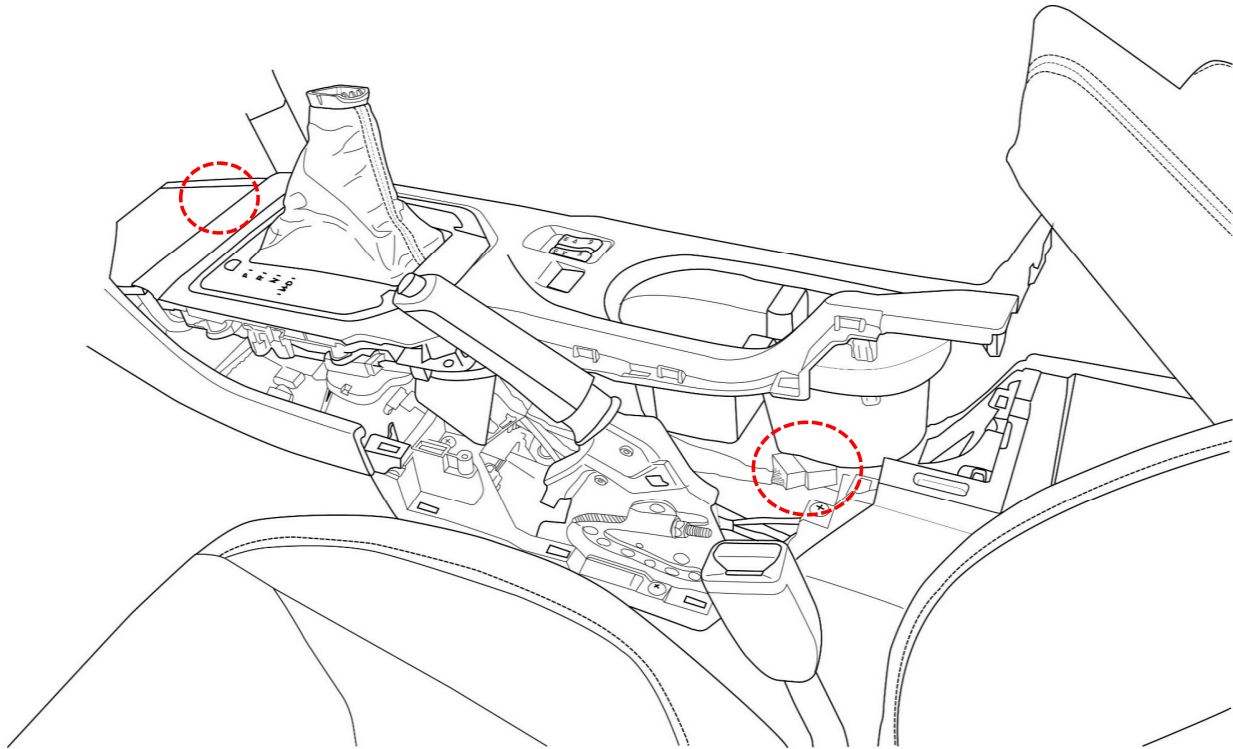

**STEP 19:** Carefully push down center console and engage all clips. Re-install screw.

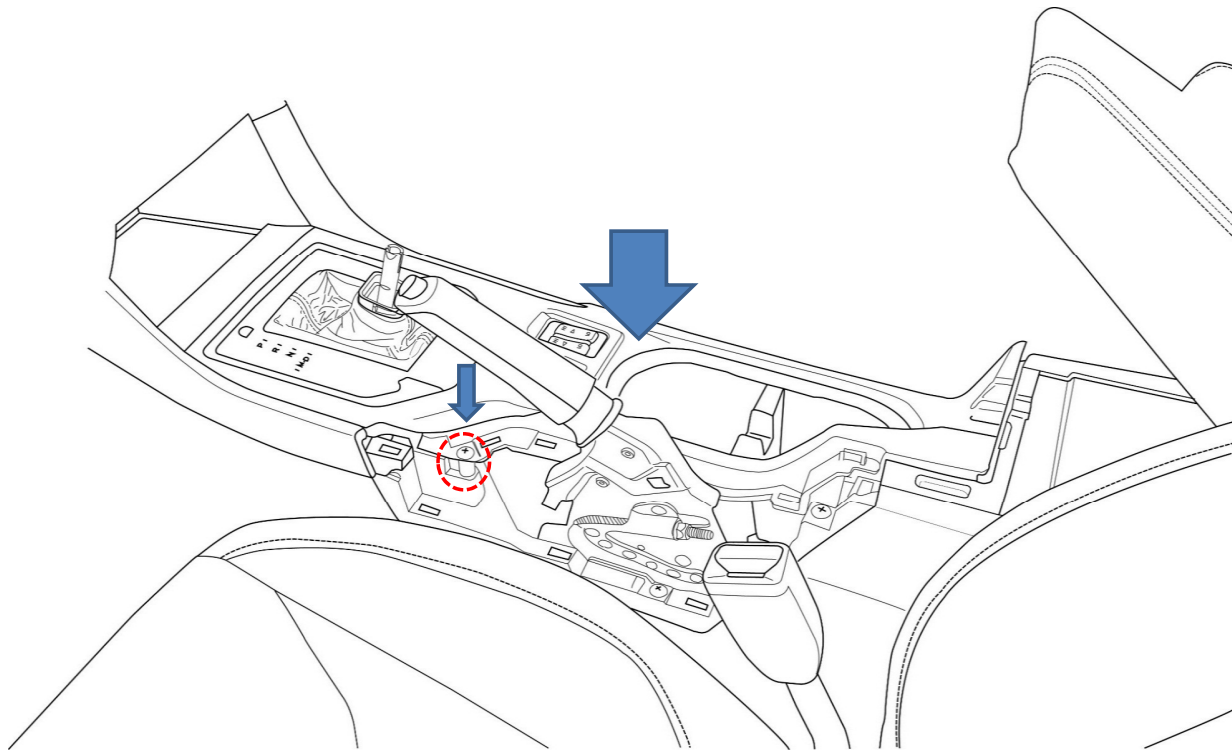

## FOR VEHICLES WITH A SHIFT BOOT (Page 2 - Page 11)

**STEP 20:** Check to make sure pin clip is still installed on the STI CVT Shift Knob. **NOTE:** Place your finger over the pin clip. Carefully align and position shift knob and then push down until a click is heard. **CAUTION:** If your finger is not placed over the pin clip during the downward push, the pin clip may eject and get lost. If the pin clip comes loose, you can still install it by holding down the shift knob while inserting the pin clip towards the back of the vehicle until it engages. See reverse of Step 6.

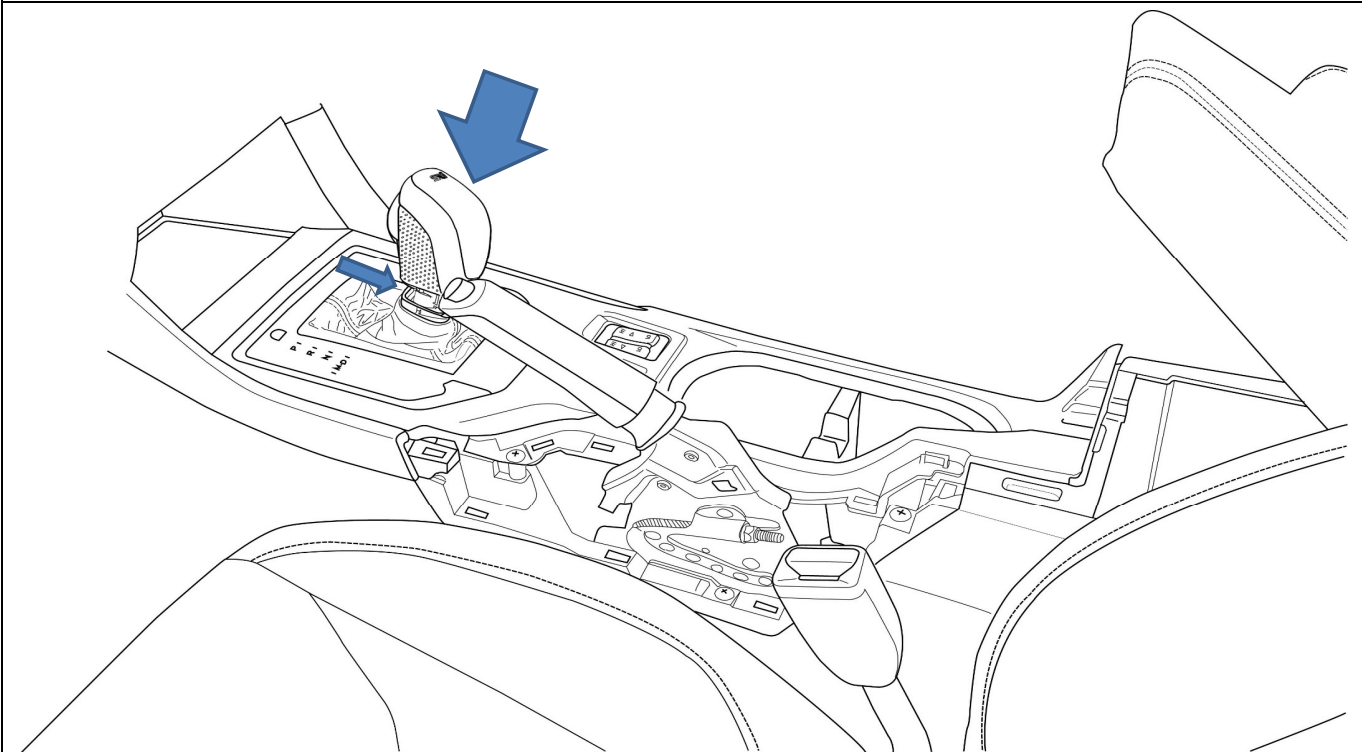

**STEP 21:** Pull up Cover Grip B, re-install parking brake boot, check to make sure center console is fully down.

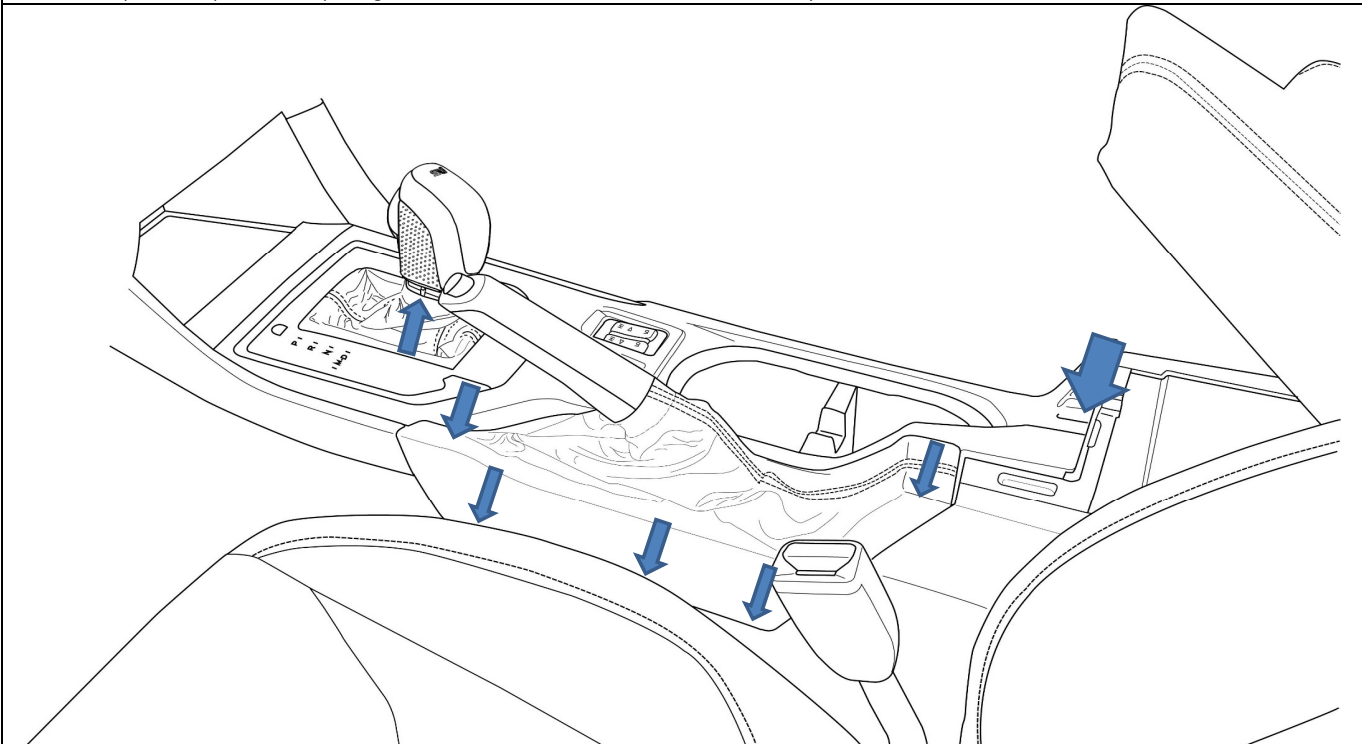

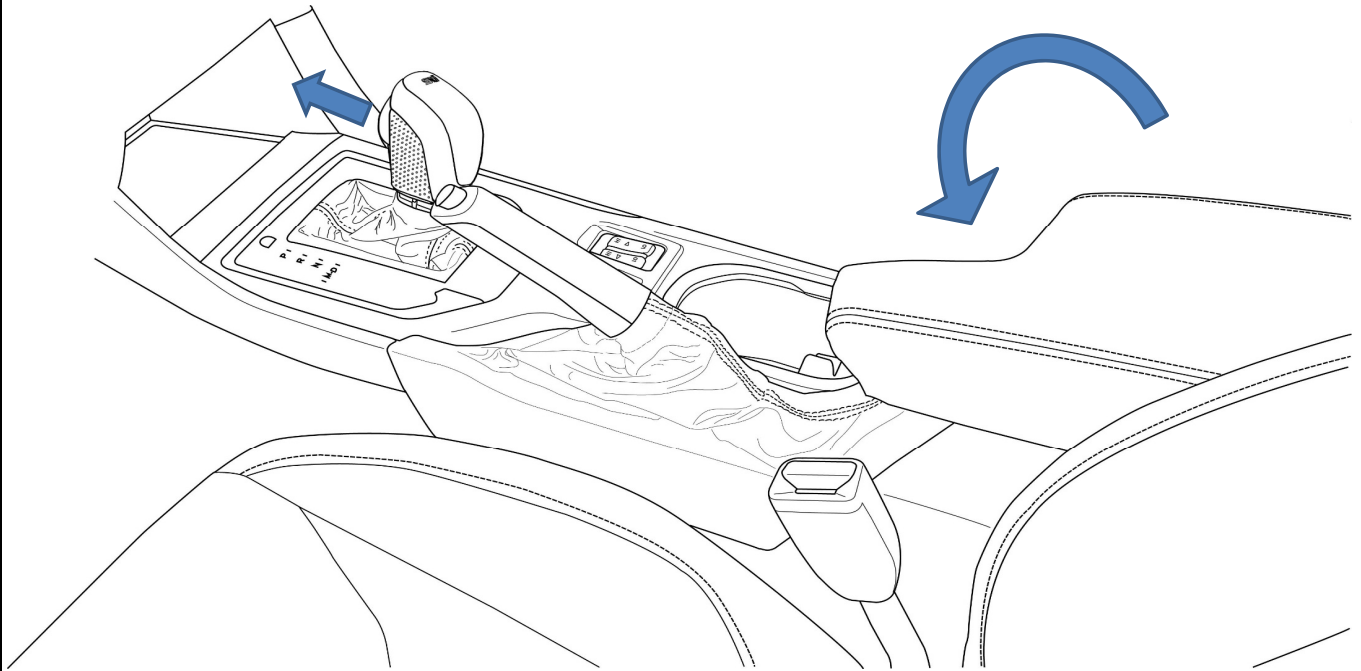
**FOR VEHICLES WITH A SHIFT BOOT (Page 2 - Page 11)****STEP 22:** Close armrest. Depress brake pedal and shift vehicle into Park.

**STEP 23:** Reconnect negative battery cable in the figure below. Confirm that the shift knob is firmly installed and that the button can be fully depressed. Make sure the shift knob is properly installed before operating the vehicle. Turn on ignition, depress and hold brake pedal, confirm shift lever cannot shift out of "P" without depressing button.

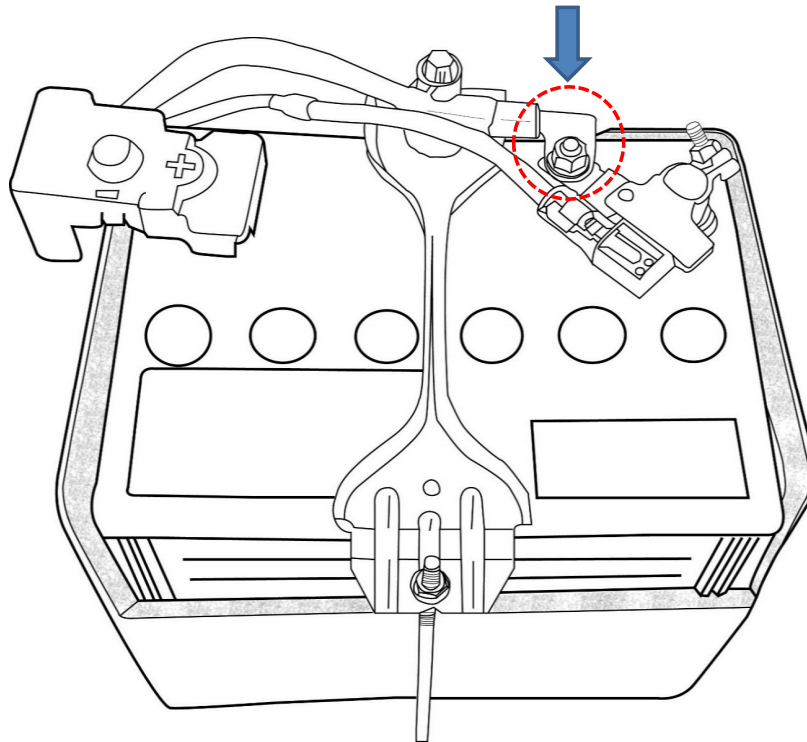

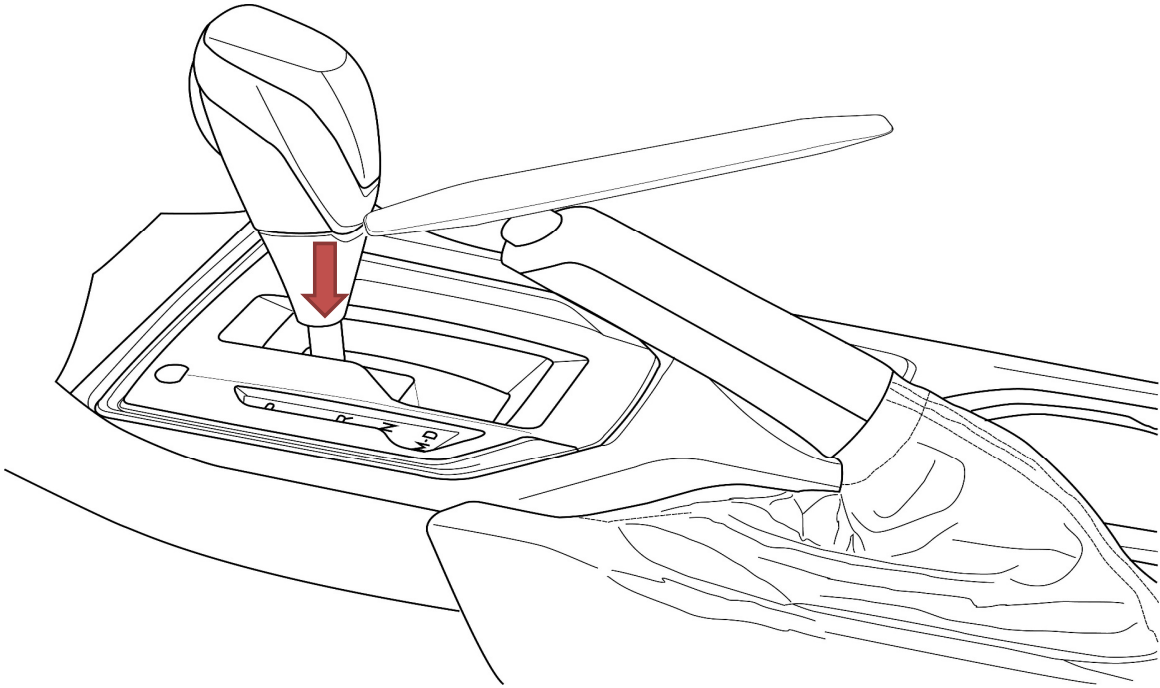
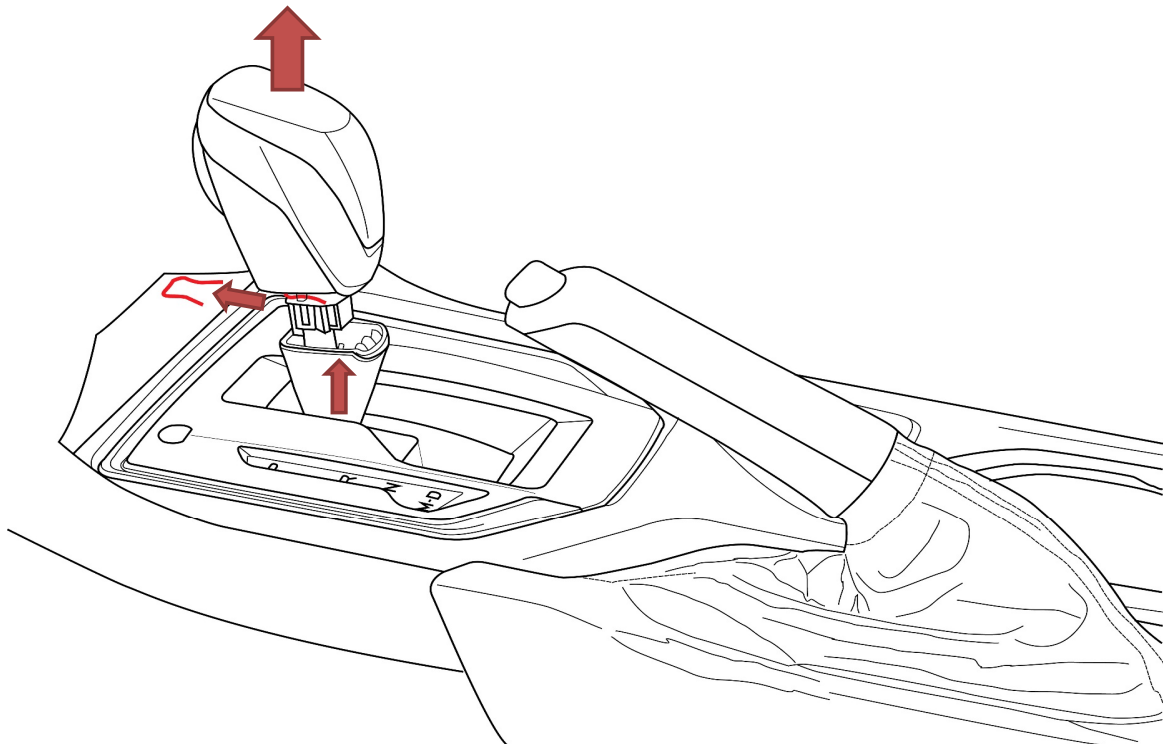
**FOR VEHICLES WITHOUT A SHIFT BOOT (Page 12 - Page 14)****STEP 1:** Park vehicle on level surface. Apply parking brake. Turn ignition off. Use plastic trim removal tool and pry cover grip downward.**STEP 2:** Use fingers to push pin clip forward on both sides. Remove OE shift knob.

FOR VEHICLES WITHOUT A SHIFT BOOT (Page 12 - Page 14)

STEP 3: Drop in new Cover Grip A.

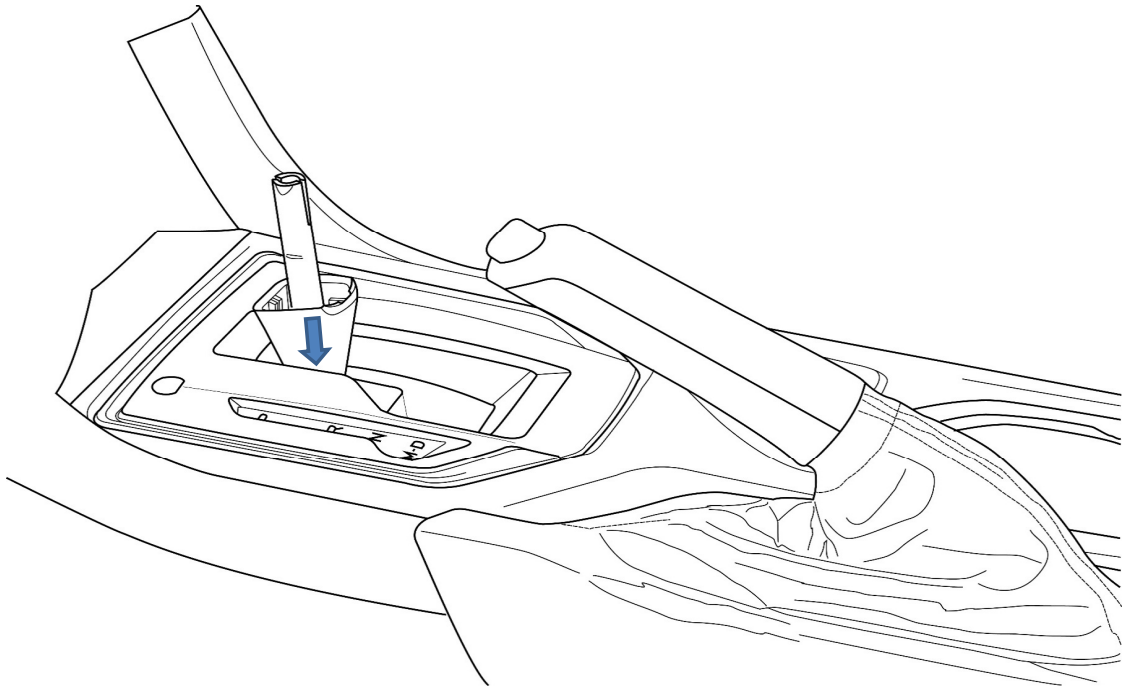

STEP 4: Check to make sure pin clip is still installed on the STI CVT Shift Knob. **NOTE:** Place your finger over the pin clip. Carefully align and position shift knob and then push down until a click is heard. **CAUTION:** If your finger is not placed over the pin clip during the downward push, the pin clip may eject and get lost. If the pin clip comes loose, you can still install it by holding down the shift knob while inserting the pin clip towards the back of the vehicle until it engages. See reverse of Step 2.

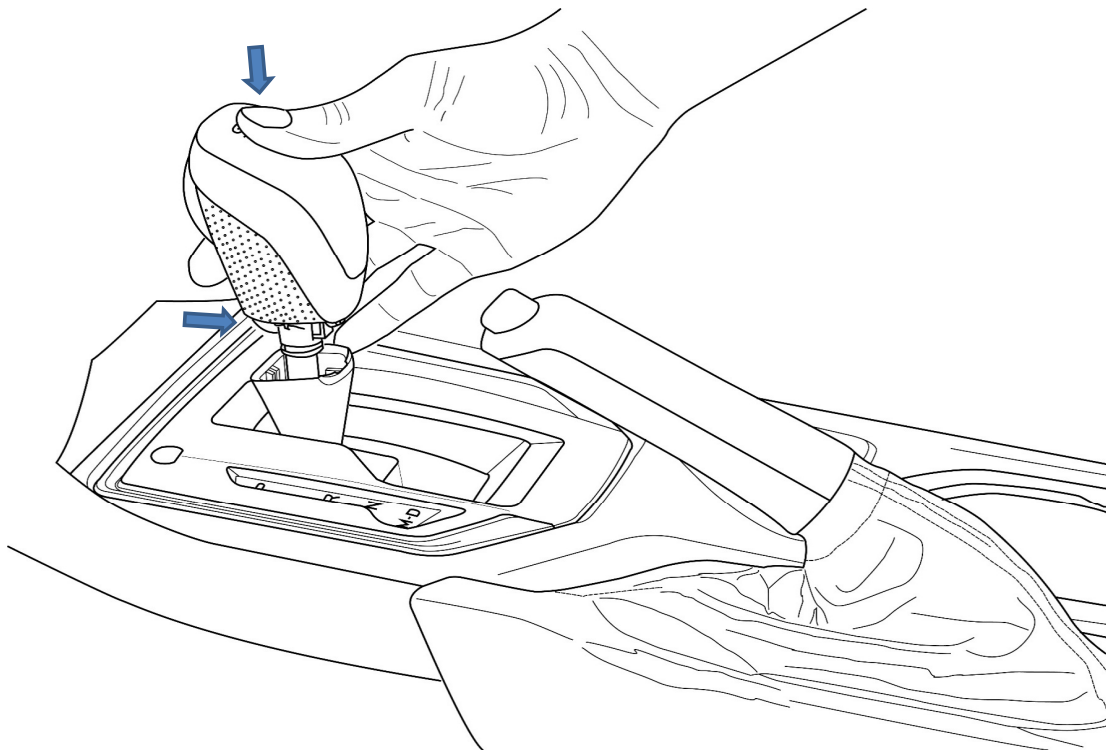



**FOR VEHICLES WITHOUT A SHIFT BOOT (Page 12 - Page 14)**

**STEP 5:** Pull up Cover Grip A until it clicks. Confirm that the shift knob is firmly installed and that the button can be fully depressed. Make sure the shift knob is properly installed before operating the vehicle. Turn on ignition, depress and hold brake pedal, confirm shift lever cannot shift out of "P" without depressing button.

